

# LOVE TO SHINE

PRODUCT RANGE



LTS  
LOVE TO SHINE

LIKE  
THE  
STARS



LTS  
LOVE TO SHINE



COME  
WORK  
**WITH US**

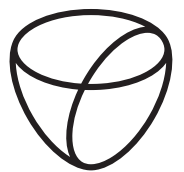

**LTS**  
LOVE TO SHINE

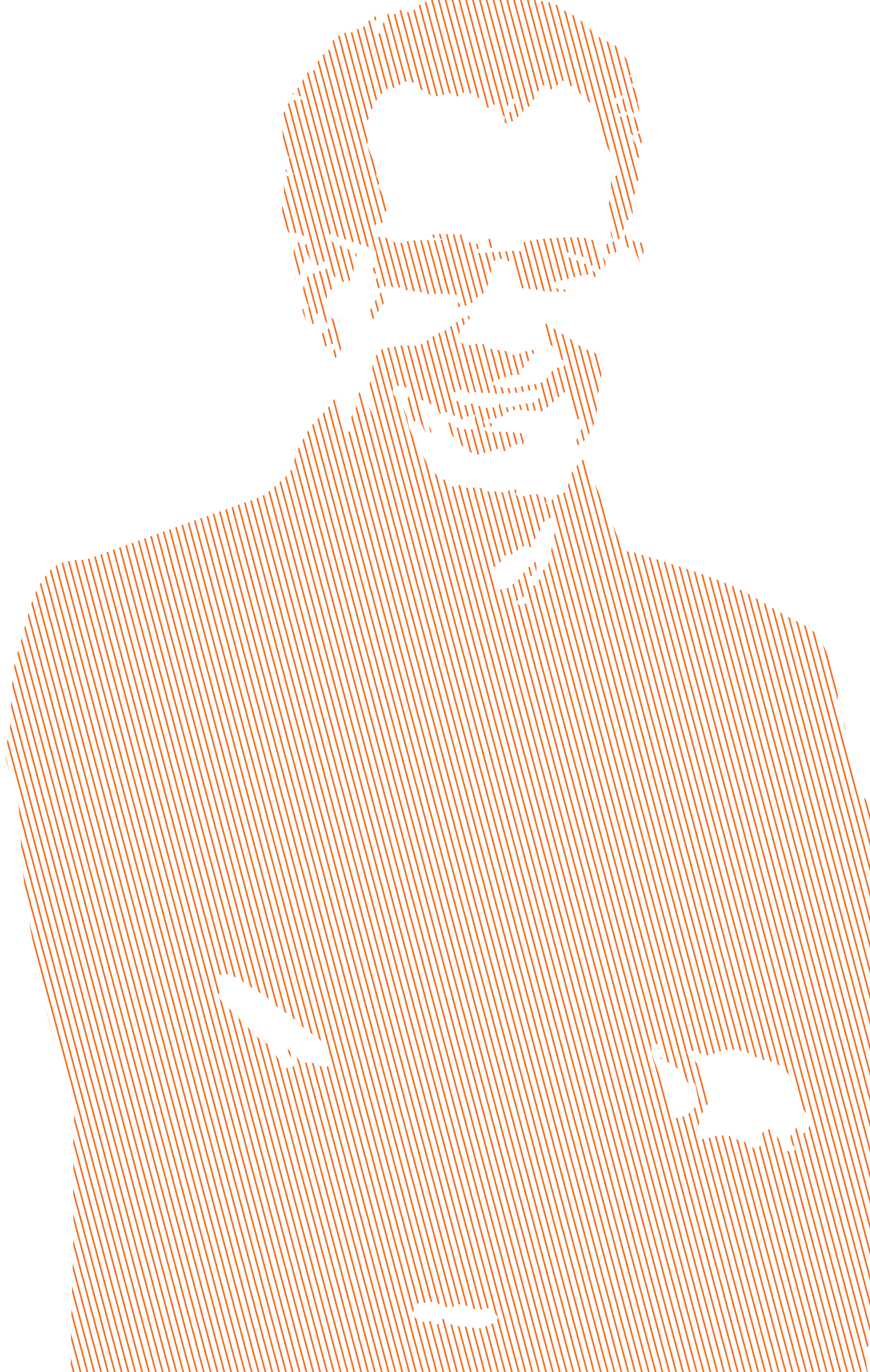

# DOES LIGHT BRING HAPPINESS?

**Dear customers, esteemed business partners,**

My answer is “Yes”! For us, light is more than just a physical quantity – it invigorates the senses and energizes the mind and body. This dynamism is visible in us and our products. We love light!  
Our new claim LOVE TO SHINE summarizes exactly that in memorable and powerful words, and you will also notice it in our new catalogue which you are holding in your hands.

For us, the new LTS brand means connecting the best from the past with the goals of the future. We are living our values of **dependability, openness, efficiency, authenticity, technology and premium quality** on a daily basis. We are showing our colours and addressing new challenges. You can physically see this in our new presentation: A new logo, the claim and strong colours bring brilliance to our “new face”. On my first day at LTS I sensed that this company was a gem, and now we are also sparkling like one. We want to be the most dynamic lighting partner in the industry for you. This is what we are working on and it is my promise to you!

With our shared passion for light, long-standing traditions and our impressive innovative strength we present a high-quality product portfolio which is developed and manufactured in Tettngau on Lake Constance. With a strong commitment to being „Made in Germany“, we stand by our Swabian heritage and our long-serving staff team. Furthermore, LTS works closely together with 18 sheltered workshops in the region. Thanks to the trust you place in us, our lighting solutions and the resulting business partnerships we can take on our social responsibility together.

At this point, I would like to thank you for your trust in us and your loyalty to LTS. Our inventiveness and courage to embark on new paths has shaped the 30-year history of the company. Based on this experience, we have created sustainable lighting solutions that are perfectly tailored to meet a multitude of requirements and make us stand out. We are delighted to continue offering our reliable products and customised services, always meeting your individual needs.

Until next time!



**Michael Cappello**

# LOOKING FORWARD TO ...

|                              |     |
|------------------------------|-----|
| Foreword                     | 2   |
| Table of Contents            | 4   |
| <hr/>                        |     |
| Love of Light from the Start | 6   |
| On a Personal Note           | 8   |
| LTS Worldwide                | 10  |
| Enjoy the Show               | 22  |
| Knowledge Brings Expertise   | 24  |
| How We Work                  | 26  |
| <hr/>                        |     |
| Product Overview             | 28  |
| Track-Mounted Spotlights     | 36  |
| Recessed Spotlights          | 56  |
| Dallton Configurator         | 74  |
| Surface-Mounted Downlights   | 92  |
| Recessed Downlights          | 98  |
| Lighting Systems             | 118 |
| Ceiling & Pendant Luminaires | 124 |
| Lichtkanal Configurator      | 142 |
| Free-Standing Luminaires     | 170 |
| Wall Luminaires              | 178 |
| Insert Luminaires            | 184 |
| High-Bay Luminaires          | 190 |
| Contact Tracks & Accessories | 194 |
| <hr/>                        |     |
| Index                        | 204 |
| General Terms and Conditions | 206 |
| Imprint                      | 208 |



TRACK-MOUNTED  
SPOTLIGHTS



WALL  
LUMINAIRES



CONTACT TRACKS  
& ACCESSORIES **194**



36



RECESSED  
SPOTLIGHTS

56



HIGH-BAY  
LUMINAIRES

190



178



FREE-STANDING  
LUMINAIRES

170

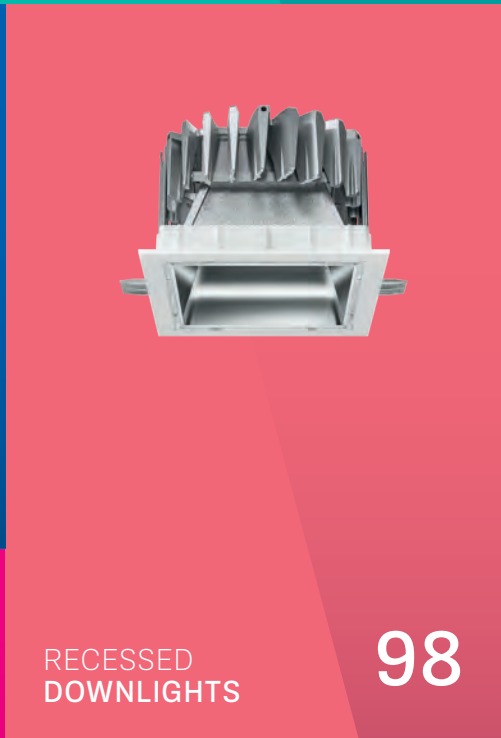

RECESSED  
DOWNLIGHTS

98



INSERT  
LUMINAIRES

184



SURFACE-MOUNTED  
DOWNLIGHTS

92

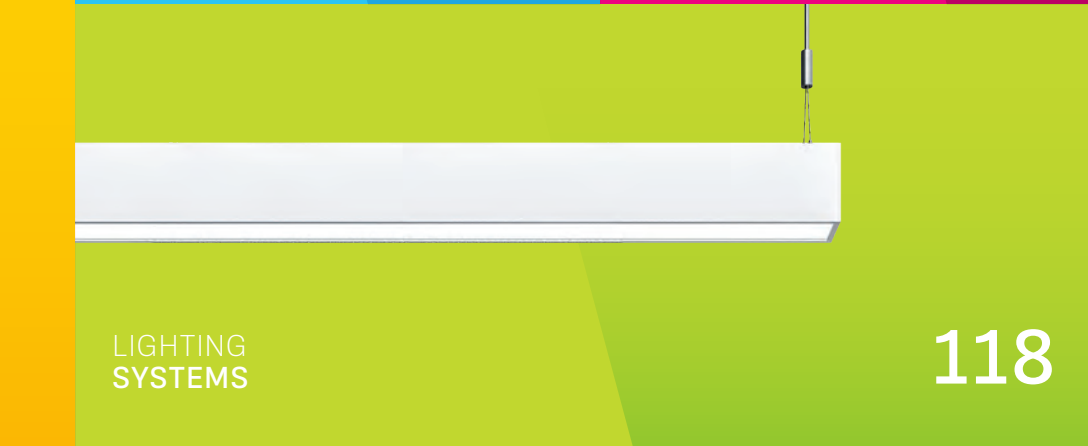

LIGHTING  
SYSTEMS

118

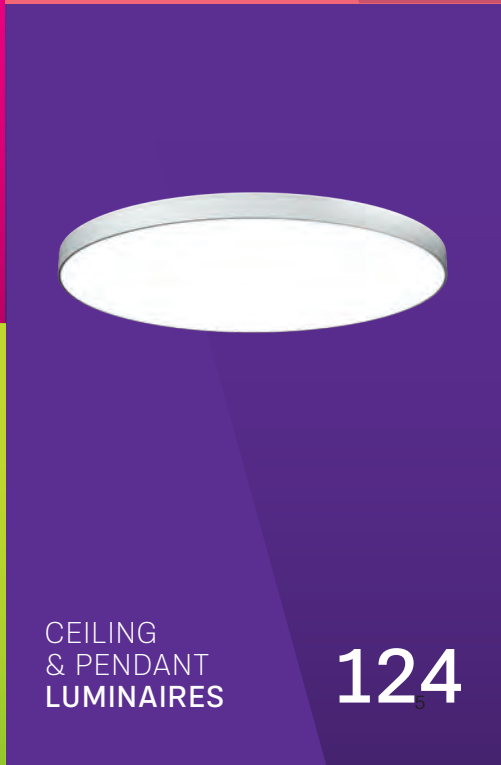

CEILING  
& PENDANT  
LUMINAIRES

124

# LOVE OF LIGHT FROM THE START



## It all began in... 1985

Long before everyone started talking about start-ups, the success story of LTS began in a small garage in the Upper Swabian town of Ravensburg. Two brothers, a master electrician and a businessman, founded the company which is now operating globally. The twin brothers started with luminaires for shops and store decoration. Their goal was to present the products in the retail sector in a better light. Their innovative lighting solutions quickly became known beyond the region.

As a result, the garage company was bursting at the seams as early as 1988. The founders of the company set up a new home in Schäferhof in Tettngang. To this day, Germany, or more specifically Swabia, is the one and only base for our premium-quality branded products – our state-of-the-art LED lighting solutions. The production site on Lake Constance is a clear commitment to our Upper Swabian home in the district of Friedrichshafen. This is where we have set down roots.

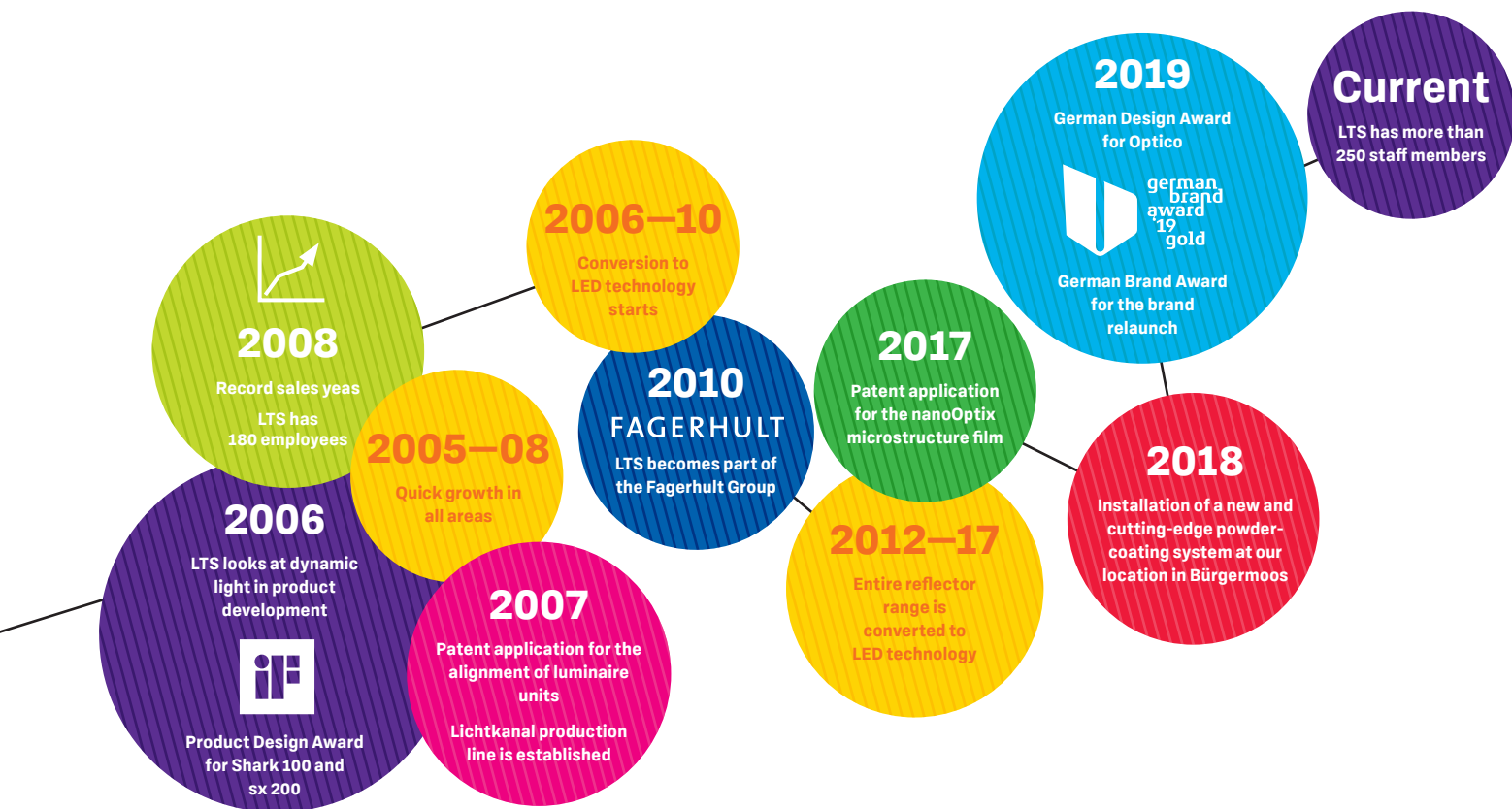

## In-house innovative strength and quality

Electricians and developers, engineers and designers, architects and sales representatives work hand in hand at LTS. New trends are tracked down together, high-quality solutions are developed, scientifically tested and perfectly implemented. For this reason, LTS possesses a number of utility model specifications and patents for ground-breaking lighting solutions. For example, our reflector technology made us the world market leader in 2000.

## Radiating into the whole world – from Tettngang

LTS has been a part of the Fagerhult Group since 2010. “Think global, act local” is the motto of the Swedish group, consisting of 13 independently operating companies. Being a member of a group that only works with strong and economically sound subsidiaries means LTS is ideally placed to be internationally connected. The high-quality product range of the sister companies offers the perfect complement to our own portfolio. In this way, we can implement complex projects on a new scale at an international level. All from a single source!

## Dynamic brand in a new light

Returning to values that demonstrate meaning and identity and focussing on our core strengths has led to a process of development towards a new profile. Since the end of 2018,

LTS has had an innovative brand image with a dynamic look. The focus is on a new logo, which not only contains the initials, but also embodies a cup, a diamond, a heart, as well as a luminaire unit and a reflector. It is accompanied by the new claim: LOVE TO SHINE, which gives life to the initials L, T and S. Our new company image shines thanks to the strong colours. And one central design element is the angular surface which refers to the radiation character of our luminaires. Everything together represents our great enthusiasm for light and the related focus on qualitative values, combined with a high level of adaptability.

## Social responsibility and “Made in Tettngang”

LTS has continuously increased its social involvement since 1993. Today we are working closely with 18 sheltered workshops in the region. LTS supports people in their participation in an active working life and in their inclusion. This collaboration is how we assume our social responsibility.

By now, the entire LTS team is formed of approximately 250 employees, who all work on reliable lighting solutions. All the process steps in assembly are carried out manually. Manufacturing is supported by cutting-edge articulated robots. And the patented reflectors are still produced exclusively on Lake Constance. An in-house powder-coating system completes our collection of high-tech machinery and ensures independence in production. These aspects contribute to our sustained success and make LTS a premium, fast and flexible manufacturer.



# ON A PERSONAL NOTE

## 18 questions, answered by Michael Cappello

He could have become an opera singer with this resounding name, but things turned out differently. After various positions as an executive manager in well-known companies in the US and Germany, the qualified industrial engineer became the CEO of LTS at the beginning of 2018. Only a few still consider him a newcomer to the industry, but they are wrong! For this reason, we are looking forward to a conversation with him to get to know him better!

### **What do you drink at the end of a working day? Wine, water or do you prefer beer?**

I place a lot of value on energy and a healthy diet. For this reason, I drink simple tap water. We get it directly from Lake Constance. The Alps deliver meltwater to the lake. Coming from one of the most important mountain ranges in the world, this water is of a special quality. I draw strength from it.

### **Bread or bread roll?**

Whole-grain bread, also because we don't really have what you would know as a bread roll in Swabia. As I have learned, they are called "Weckle" here.

### **Barefoot or dress shoes?**

Actually, I prefer trainers. They allow for optimum movement and help me go quickly from thinking to doing, in other words, they get me moving. For me personally, trainers represent both high functionality and a great standard of design. I am not sure that my sneakers look as cool as my children's, but maybe it's best that way. *Cappello is laughing.*

### **Where do you like to go on holiday?**

I like to be where I am surrounded by my family and friends. I spent my last holiday in Sicily. I love the special atmosphere and the invigorating brightness. I am well aware of the fact that light influences our health and well-being, but I am still fascinated every single time when I experience it personally. Even a dull sky produces several thousand lux in Sicily. That's a real pick-me-up.

### **What is the ugliest word of the German language that you can think of right now?**

I don't like the abbreviation we use for conference call: Telko. It's a cross between the words "Telefon" and "Konferenz". But given that I always try to focus on the positive, instead I would like to tell you a word that means a lot to us at LTS: passion. Working with passion means that you are engaged and act with empathy. You will only be able to offer the right solutions if you know your clients. That is my definition of "service-oriented".

### **Your favourite animal?**

The chamelephant. A combination of an elephant and a chameleon. An elephant has an excellent memory and is a good listener. The chameleon adapts to any given environment. In reference to our clients, this is exactly what we offer: custom-designed lighting solutions.

### **Call or text message?**

At LTS we are intensively involved with digital transformation and innovative technologies, but I admit I am a fan of analogue leadership culture and personal conversations.

### **Do you ever have problems sleeping?**

No. That is because I can rely on my team. For me, trust is the basis of further development. No matter at what level and in which position – trust always starts with yourself.

### **Do you have a Swabian side?**

Swabians are said to be very diligent

and inventive, and rightly so. These are characteristics that also describe LTS. Personally, I mainly share the humility that sometimes keeps us from being extremely proud of what we have achieved.

### **Sports car or SUV?**

If I had to pick, I would go for the faster option. What's great about my favourite car is the high level of reliability and efficiency. I am sure the manufacturer copied that from our luminaires. *Cappello is laughing.*

### **Which joke makes you laugh?**

I love to laugh, preferably at myself, but I am really bad at telling jokes.

### **Netflix or television?**

Neither nor. I am a great fan of podcasts. But I would rather invest my free time in my family or sports. If I still have some free time at home, then I like chess; not learning how to play chess but rather learning from chess. This game is about the art of changing perspectives and a combination of cool reason and intuition.

### **Home or abroad?**

Home is very important to me personally, but home is not a place, it's a feeling. For LTS, I prefer the wider world. We want to become the most dynamic brand in the lighting industry in the relevant international markets. This is ambitious, I know, but setting this goal has already got things moving within our team.



**What does collaboration with the other Fagerhult subsidiaries mean in practical terms?**

With an increasing consolidation in the global lighting industry, it is important to take on a very active role. Instead of getting bogged down in details, with the Fagerhult Group we have the possibility to think and act big. LTS offers its clients a full range of products and services. It is like a good flat-sharing community: We can benefit from one another and provide mutual support, however, we all have our own rooms to retreat to. This is how we can maintain our creative independence and further develop individual core competencies.

**Daylight or artificial light?**

As a matter of fact, we live in biological darkness because we are no longer shaped by daylight but by artificial light. We have to adapt to this development with extensive research. While, for a long time, light design was all about brightness and about making buildings and objects shine in a positive light, today the focus is primarily on the health effects on humans.

**Do bosses and employees live in parallel worlds?**

This is probably a matter of perspective. Managers mainly see their world from the company perspective and easily forget how important interpersonal relationships are. But in order to be able to successfully implement projects, they depend on their team. Employees must learn to keep in mind a sense of overall responsibility that is becoming increasingly important in our networked working environment.

**What have you reflected upon this morning?**

We are proactively searching for staff members to work in various areas and are confronted by the fact that the change from an employer's market to an

employee's market is in full swing. Unlike in the past, companies now have to make a real effort to be perceived as attractive employers. Young employees have very specific ideas of how they want to organise their professional lives. They no longer want to accept poor leadership, rigid structures and a lack of scope for experimentation and for exactly that reason we are the right place for them. We are different. We LOVE TO SHINE.

**Your favourite quote?**

It is better to light one small candle than to curse the darkness.

**Thank you very much for your openness and the interesting conversation.**

You're welcome, it was fun.





# LTS WORLDWIDE

Come with us on a journey through our work and be inspired – by the spaces that are illuminated by LTS.

For 34 years, we have been rooted in Tettngang and our home region of Lake Constance. We develop and produce our premium-quality products here in two locations. Very deliberately from a single source and all “Made in Tettngang”.

It is important to us to be in direct contact with our clients, so we have local contacts on site. 21 colleagues work as field sales staff in Germany, Austria and Switzerland. We are available to personally answer and discuss all questions relating to our innovative lighting solutions.

Our service includes sampling on site, as well as providing support when it comes to design, installation and maintenance. Our offer covers intensive guidance throughout all phases of the project. As a member of the Swedish Fagerhult Group, LTS is capable of implementing complex international projects on a new scale from a single source. With sales companies and partners in more than 47 countries, we can guarantee reliable collaboration and smooth project handling: from New Delhi to Moscow all the way to Sydney. The numerous and diverse projects we have implemented internationally are testament to this and make us proud. Renowned brands, such as Marc Cain, Porsche and Google, have put their trust in our solutions.

## GERMANY

- 1) NYX Hotel, Munich
- 2) Ravensburger, Montabaur
- 3) Gabor, Mindelheim
- 4) EDEKA, Friedrichshafen
- 5) Hymer, Bad Waldsee
- 6) SAE Institute, Berlin
- 7) Porsche, Wiesbaden
- 8) Aston Martin, Filderstadt
- 9) bulthaup, Braunschweig
- 10) Mercedes-Benz, Esslingen
- 11) adidas, Herzogenaurach
- 12) Intercity, Frankfurt
- 13) Leonardo Royal Hotel, Ulm
- 14) Jaguar Land Rover Classic Cars, Essen
- 15) Tafelzier, Nuremberg
- 16) Holiday Inn, Düsseldorf
- 17) dm, Hamburg
- 18) Marc Cain, Aachen

## THE NETHERLANDS

- 19) Esprit, Amsterdam
- 20) Wolford, Amsterdam
- 21) Volkswagen, Utrecht

## LUXEMBURG

- 22) O'Neill

## BELGIUM

- 23) SIXT, Brussels

## SWITZERLAND

- 24) Zentralbibliothek, Zurich
- 25) Google, Zurich
- 26) Consulate of Japan, Geneva

## AUSTRIA

- 27) Douglas, Vienna
- 28) Die Wälderin, Mellau

## POLAND

- 29) Polish National Radio Symphony Orchestra, Katowice

## FRANCE

- 30) Wolford, Paris
- 31) European Parliament, Strasbourg

## ITALY

- 32) dm, Venice
- 33) Dimar, Volvera



**UNITED KINGDOM**

- 34) UNIQLO, London
- 35) Microsoft, London
- 36) Jack Barclay Bentley, London
- 37) Jaguar, Watford
- 38) Specialized, Bristol

**CROATIA**

- 39) Airport Franjo Tudman, Zagreb

**HUNGARY**

- 40) adidas, Budapest

**LITHUANIA**

- 41) Apranga Group, Vilnius

**BELARUS**

- 42) Zara Home, Minsk

**SWEDEN**

- 43) Max Burgers, Umeå

**FINLAND**

- 44) Alko, Helsinki

**SPAIN**

- 45) Desigual, Barcelona

**PORTUGAL**

- 46) Google, Lisbon

**RUSSIA**

- 47) Gazprom, St. Petersburg
- 48) Delta Credit, St. Petersburg
- 49) Orange Business Group, Moscow
- 50) Moscow International House of Music, Moscow
- 51) ESCADA, Moscow

**TURKEY**

- 52) Apple Office, Istanbul
- 53) Vitra, Istanbul

**EGYPT**

- 54) City Centre Almaza, Cairo

**AZERBAIJAN**

- 55) Port Baku Bazar, Baku

**KUWAIT**

- 56) Sabah Al-Salem University City
- 57) Four Seasons
- 58) Kia

**QATAR**

- 59) Women's Hospital

**UNITED ARAB EMIRATES**

- 60) Dubai Mall, Dubai
- 61) Dubai Airports, Dubai
- 62) Ferrari, Abu Dhabi

**CANADA**

- 63) Marc Cain, Toronto

**INDIA**

- 64) Lamborghini, New Delhi
- 65) BMW MINI, New Delhi
- 66) SPS Museum, Srinagar

**MALDIVES**

- 67) Kuramathi Island Resort, Male

**VIETNAM**

- 68) National Assembly House, Hanoi

**US**

- 69) Audi, Dallas
- 70) Porsche, Santa Clarita

**SOUTH AFRICA**

- 71) Bloomberg, Cape Town

**CHINA**

- 72) Zara Home, Shenzhen

**SINGAPORE**

- 73) Amazon
- 74) Estée Lauder
- 75) JP Morgan

**AUSTRALIA**

- 76) National Rugby League, Sydney
- 77) Qantas, Sydney
- 78) ASICS, Sydney
- 79) Lion Beer Spirits & Wine, Sydney
- 80) Melbourne Airport, Melbourne
- 81) Zurich, Brisbane

**NEW ZEALAND**

- 82) Northlands Shopping Mall, Christchurch

- 📍 LTS, Tettngang





# DESTINATION #1

LTS VISITING

## TAFELZIER, NUREMBERG, GERMANY

When you walk on cobblestones through the narrow lanes and pass old half-timbered houses, you feel like you are traveling through time. Historical buildings and living history. I can feel the sun on my skin and smell bratwurst, apple juice and roasted almonds. A small smile brightens my face when I listen to the passers-by talking to each other in their local dialect. They speak Franconian here, one of the very special dialects in Bavaria. Would you have known what “a weng weng” means in German? As of this moment, this phrase is one of my favourite Franconian words and means “a wee bit of a little”.

I am standing in the shop of one of the best in his field, the pâtissier Jens Brockerhof, and I am astonished. Who is supposed to eat all of this, for heaven’s sake? Nothing is more valuable than good light, I am thinking, except for sweets presented in the right light. And there are plenty of them here. Petit fours and macarons, cakes and biscuits, chocolate and meringue. The sheer number of delicacies whets the appetite and leaves you wide-eyed.

### CREAM OF THE CROP!

The countless calorie bombs are presented like pieces of jewellery in extensively illuminated display cases. Accentuated lighting and a touch of chocolate rest upon the bonbons that are elegantly enthroned on pedestals. Having worked successfully with the trade, LTS can rely on its experience and offer the right special light colours for confectionary and pastry. LED light in neutral shades ensures a high-quality reproduction of the colours of the cream cakes.

The spotlights of the Jett series shine subtly from the darkness of the ceiling. They do not emit direct heat to make sure that the sweet pieces of art behind the counter always remain appetizing. At Tafelzier, the sophisticated lighting concept is perfectly adapted to the delicious products. Mounted on contact tracks, the light can be varied as desired and depending on the season. I feel a sense of happiness inside of me, but it might also be the craving for something sweet.





# DESTINATION #2

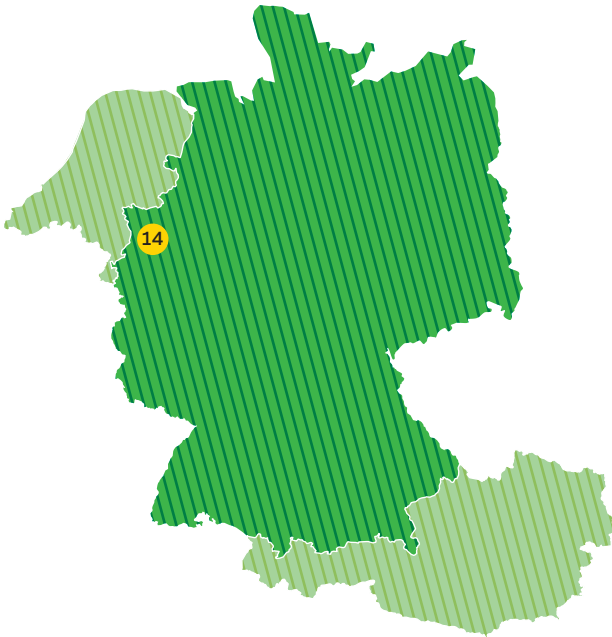

## LTS VISITING JAGUAR LAND ROVER CLASSIC CARS, ESSEN, GERMANY

The 6-cylinder roadster purrs softly when I put my foot on the accelerator. I am driving through the Ruhr region, the southern part of Essen, in a light blue, sporty two-seater with a convertible top and a long bonnet. I like it here, at the Margarethenhöhe, a listed neighbourhood from the 1930s. The charming district is as old as the car which I was allowed to test drive. And the car looks as beautiful today, 50 years after its first registration, as it did back then and that is thanks to the car dealer:

The Jaguar Land Rover Classic Centre on the Ringstraße in Essen-Kettwig. In an area of 4,500 square metres, the most elaborate factory restorations are performed and the most beautiful cars are offered for sale.

### A SPORTS CAR SHOULD LOOK FAST, EVEN WHEN IT'S STANDING STILL!

The exhibited classic cars have their own history. Besides the sentimental value, they cost between 40,000 and 600,000 euros. I am looking through a glass wall in the showroom at five operating platforms in the workshop. Vehicle mechanics are busy inspecting, repairing and assessing cars. LUZ track-mounted luminaires overhead illuminate the space and provide for a glare-free working environment.

Given that a longer-length lighting solution was needed in the extensive showroom, the architects opted for the StraitLine light line. It delivers uninterrupted light at a length of 19 metres. The linear character is continued in the floating ceiling panels where the Lichtkanal is installed flush with the ceiling. What also impresses me is the enormous ceiling height which makes the showroom look even more spacious. Lighting solutions have been installed at a height of five metres. Nevertheless, the brilliant light is second to none as it makes the staff members feel comfortable and the exhibited products are optimally illuminated.

Spotlights for StraitLine provide accentuated lighting and present the details of the classic cars in a particularly attractive manner. The high colour reproduction of the luminaires makes it clear to me that these vehicles shine both under the bonnet thanks to their sophisticated technology and on the outside with their high-end paintwork. As a result, I find it even harder to return the key of the sports car and to leave North Rhine-Westphalia.









# DESTINATION #3



LTS VISITING

## WOLFORD, AMSTERDAM, THE NETHERLANDS

On the screen in the store I can see the frenzy of flashing cameras at a party in Hollywood. Stars and starlets are walking down the red carpet, photographers and fans are screaming in excitement. Madonna wears them and Beyoncé has her picture taken in them: the tights by Wolford. They are the favourite of celebrities and delight customers worldwide with their excellent manufacturing quality.

The tights are produced in Bregenz on Lake Constance, where Reinhold Wolff and Walter Palmers founded a company for artificial and pure silk stockings. When the founders travelled to Oxford they were inspired and the name of the company was born: Wolford.

Today the brand logo is positioned prominently in the shop window of the new store in Amsterdam. It is located in the most elegant shopping street of the Dutch metropolis. The bright colours make me feel welcome: white in all shades, a cream-coloured travertine flooring and light wood tones.

### BETWEEN GLAMOUR AND GLORY

The lighting is an integral element of the store concept and is in line with the Wolford brand DNA. It really highlights the delicacy and the elegance of the premium-quality Wolford collection. The Jamie spotlights cross the room horizontally on contact tracks and bathe the lingerie, stockings and accessories in a shining light. Precisely aligned, yet in the background, the modern luminaires deliberately provide accentuated lighting and draw my attention to the new season's key pieces.

While approximately 14,000 tights and 4,000 pairs of stockings are manufactured daily in production back home, I can observe how a customer is thoughtfully and calmly attended to in the flagship store. She is beaming and almost managing to outshine the customer service staff and the Jamie spotlight.









# DESTINATION #4

LTS VISITING

## DIE WÄLDERIN, MELLAU, AUSTRIA

Snow-covered mountain tops and a clear blue sky. My view is just like an idyllic postcard picture. I am sitting in a gondola of the Mellau cable car to be transported down to the valley after a perfect day's hiking. Today's agenda brought a summit hike to the Kanisfluh. The Kanisfluh, the local mountain in Mellau, is one of the most distinctive mountains in the region and a landmark of the Bregenz Forest.

Now I am looking forward to a relaxing end to the day in the four-star Die Wälderin hotel directly opposite the cable car. In fact, it is one of the largest hotels in the Bregenz Forest area, but the warm welcome in the bright entrance allows me to immediately feel the cosy atmosphere of the family-owned business.



### HIGHLIGHT IN THE MOUNTAINS

The LTS recessed spotlights of the CSA series provide a pleasant general illumination in the lobby. The space brings a combination of family traditions and modern Vorarlberg architecture. Bernd Frick, son of the senior director Herbert Frick, furnished the hotel with lots of wood, glass and natural materials. "For the most part, we relied on craftspeople from the region," Herbert Frick explains, "and on LTS for the light".

The CSA recessed spotlights also subtly accompany me on the way to my room. A small spotlight from the Flixx series welcomes me atop the door and allows me to easily enter my room. Finally it's time to take off my hiking boots and to get into my robe. The light-flooded room is additionally illuminated by the surface-mounted Button Mini downlight. Everything appears spacious and atmospheric – the ideal haven to relax.

Now I can unwind and rest my feet in the spa and wellness area. The alpine panorama is my constant companion through the large window façade. The Lichtkanal, which is recessed in the ceiling edges, provides for indirect light and a sense of intimacy and well-being.

I encounter the same lighting atmosphere at the hotel bar at the end of my day. The Lichtkanal visually separates the bar from the rest of the space. The lighting concept has been masterfully executed because here in the back, the atmosphere is casual and cosy. The light gently suffuses my ice-cold gin and tonic. A perfect day comes to an end.













# DESTINATION #5



## LTS VISITING **DOUGLAS, VIENNA, AUSTRIA**

Cheerful passers-by swarm side by side in the Mariahilfer Straße, the main shopping zone of Vienna. Locals and tourists are walking at a smart pace to get coffee, attend a meeting or possibly to do some shopping.

I am frowning. I am thinking about what souvenir to bring back home. A Viennese Schnitzel or chocolatey Sacher cake would be difficult to transport. So I decide to visit Douglas, Europe's leading perfumery brand.

The glass façade and the seven-metre-high atrium in the entrance area make me marvel. It is fragrant, shiny and glittering. Beauty, I am thinking, is in the eye of the beholder, but now I know that you can actually buy beauty. In an area of 455 square metres, the retailer offers thousands of items, including fragrances, creams and cosmetics by Estée Lauder, Chanel and others.

### BEAUTY REQUIRES LIGHT

Straight-lined furniture and elegantly curved design elements lend a luxurious look to the perfumery. Architect Volker Metz designed a new concept named "grey 024" for Douglas in Austria. It is derived from the RAL colour which is consistently implemented in the converted shop. For this reason, even the luminaires used were produced specifically in this colour shade so that they would subtly fit into the ambience. Their main task is to make the flacons, precious glass bottles and high-quality packaging sparkle. Spotlights on contact tracks with narrow beam angles provide a focused accentuated illumination, drawing the gaze to the very special personal care products.

And then I know exactly what to buy today. I purposefully make my way to the men's department. The lean track-mounted spotlights of the Torpedo series and compact spotlights of the Jett series bring extra illumination to the shelves. They create a lively play of light on the otherwise dark walls. Just a few SCS light systems on the ceiling are sufficient to provide a pleasant basic lighting from the sales room down to the ground floor.

There it is: a truly manly luxury beard grooming set. It contains a hand-crafted razor from Solingen, in which my three-day stubble is reflected. This kind of originality is essential, I am thinking while I start heading back home to Tettwang.



# ENJOY THE SHOW

EXPERIENCE PRODUCTS LIVE IN THE SHOWROOM

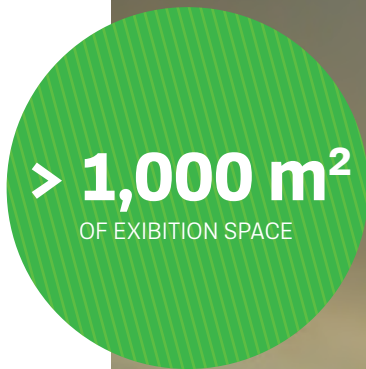
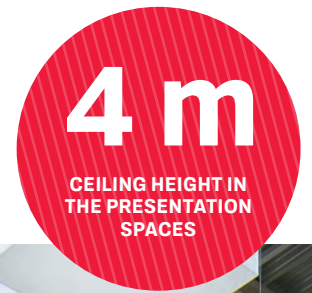

The exhibition space is a platform for those interested in light, for those who would like to practically try out our products and technologies. Once you hold the luminaires in your hands, feel the material and see the colour, choosing is easy. You can also test our lighting solutions in a mounted position and in a specific shop, hospitality or office application.

In a specifically created mock-up area, we can simulate any space situation taking into consideration the individual requirements. For comparison purposes, the mock-up area is illuminated with different light qualities. This provides a basis for decision-making to then select the best illumination solution.

**Be our guest and visit us – also with your client for a consultation if you wish!**





OPENED IN  
**2004**



**518**  
LIGHT SPOTS

LOCATION:  
**WALDESCH 24,  
TETTANG**

**27,900**  
HOURS OF LIGHT

since the first day of the showroom,  
since the first installed luminaire,  
daily from 8 am to 5 pm,  
200 days a year

**★**  
**CELEBRITY GUESTS**

**Nik Schweiger**, interior designer, is the owner of Barefoot Design – and the brother of Til Schweiger, a famous German actor

**Ulrike Brandt** is an expert in the field of lighting design and owner of the eponymous offices located in Hamburg

**Anne Haug** is a professional triathlete, Olympic athlete and qualified sports scientist

**20**  
EVENTS PER YEAR,

including the LTS Lichtforum,  
internal events, staff training  
and press events

Would you like a personal  
appointment?  
**+49 7542 9307-0**

# KNOWLEDGE BRINGS EXPERTISE

Optimum light is a complex subject and, time and again, it is a topic of conversation due to new developments and trends. At the LTS Lichtforum, participants gain valuable knowledge about everything relating to lighting – an essential aspect of being able to offer expert advice and a great help in daily work. All knowledge-based seminars are adapted to the level of knowledge and interests of the participants. The events take place at the company location in Tettng and other locations all over Germany.



**Maren Breitenberger**  
Dipl.-Ing. Interior Architecture,  
MSC Architectural Lighting Design

**Since 2016**  
Manager of the LTS Lichtforum

**Since 2015**  
Visiting lecturer and workshop  
instructor at various universities

**Maren Breitenberger has worked for LTS since 2011. The qualified interior designer and lighting designer is the face of the LTS Lichtforum. The lighting expert explains in an interview what is so special about the seminar series.**

#### **Who is the LTS Lichtforum intended for?**

It is aimed at anyone who would like to develop their skills in the field of light and illumination. It is of particularly special interest for design professions because we always discuss the state-of-the-art of science and technology.

#### **Which subjects are covered at the LTS Lichtforum?**

The subjects are wide-ranging, starting with the basics (“What does lux and lumen mean?”), moving on to the history of lighting, all the way through to discussing directives and standards – the seminar covers hard facts. We also talk about different light qualities and the perceived effect of light on humans, a space and the atmosphere. Of course, we are also happy to address individually requested topics.

#### **Why are these seminars offered?**

As a medium-sized company producing in Germany, if we want to continue to grow in the lighting market we have to offer more than what you can purchase online at affordable prices. First of all, only trained specialists are capable of differentiating between poor-quality and high-quality light. Secondly, as a reliable partner, we would like to create solutions alongside our clients that are as clear and simple as possible. Long-term collaboration will only be possible in a partnership that is based on trust and skill.

#### **When and where do the training sessions take place?**

There are some events with fixed dates taking place all over Germany, and anybody can register for these. In parallel, we offer individual events, usually here in Tettng, including a workshop visit and covering subjects that the client asks for.

#### **What question do participants ask most often?**

What about LEDs and blue light? How harmful is it to us humans really?

#### **And?**

Anyone who is interested in hearing the answer to this and other questions is warmly invited to join one of the seminars at the LTS Lichtforum.

#### **What feedback do you remember most?**

If we get feedback, it is usually very positive. I remember a very kind comment one participant made after a training session: “I thought I knew about light. But after today’s event, I know that there is still more to learn.”





**Elektro Fix  
Uwe Kotzelnick**

Potsdamer Straße 2  
19063 Schwerin  
+49 385 300087-0  
[www.elektro-fix.de](http://www.elektro-fix.de)

**Uwe Kotzelnick is a master electrician and owner of a medium-sized company in Schwerin with ten staff members. He participated in the LTS Lichtforum in May 2019. In a conversation, he describes his positive experience.**

**How did you learn about the LTS Lichtforum?**

Through my personal contact at LTS. We are always looking for further training possibilities so the LTS Lichtforum in Tettngang was a great opportunity.

**Why did you participate in the LTS Lichtforum?**

We weren't just excited about the aspect of further training, but also about the direct contact with the producer, with the industry. At a trade show it is not possible to get to know a company and its product so well and to such an intensive extent as we did on site in a personal conversation.

**What did you like the most?**

I was amazed by the size of the newly designed showroom. Everything about the showroom points towards the future. The LTS light expert, Maren Breitenberger, didn't just speak about challenges but also demonstrated solutions, particularly for custom-fit lighting. The technical details were explained and the relevant control technologies were presented. Her talk covered both market innovations and exciting developments in the area of LEDs. The quality of light was also discussed. And the LTS Lichtforum was rounded off with a current market analysis and a concluding outlook.

**Which details do you still remember?**

Everyone perceives the colours of light differently. We experienced how you can influence the bio-rhythm and the productivity of humans with light. This relates to lighting control.

My employees and I deal with light on a daily basis so the presented solutions using high-quality light offer added value to me in my client consulting work, and more importantly, to my clients themselves. My clients' objective is to improve their sales figures in retail by having good-quality light. In the end, quality pays off.

**How can you make use of the input you gained from the LTS Lichtforum for your clients?**

My goal is to create client loyalty through professional advice and high-quality products. With clients who opt for quality, expertise and service, I know that the initial investment can be high, but, at the end of the day, the client is rewarded by the perfect lighting solution and an increase in sales.

**Who are your clients?**

Retail clients in the clothing and cosmetics industry. It is important to help your client to see that good light boosts sales.

**Would you recommend the LTS Lichtforum to your colleagues?**

Yes, absolutely – because further training is essential in our fast-moving age. It is the only way to get ahead of the game and keep your competitive edge. Products are always outpacing each other in terms of their development, and only those of us who stay on the ball will survive in the market.

**Would you visit the LTS Lichtforum again?**

Yes, of course! I'd love to learn about another subject, for example office lighting. I think the future will hold many changes in that area. LTS has already taken a step into the future with their ceiling luminaire Optico and their free-standing luminaire range. We would like to help our clients to take this leap as well, and this is only possible with expert knowledge and experienced consulting.

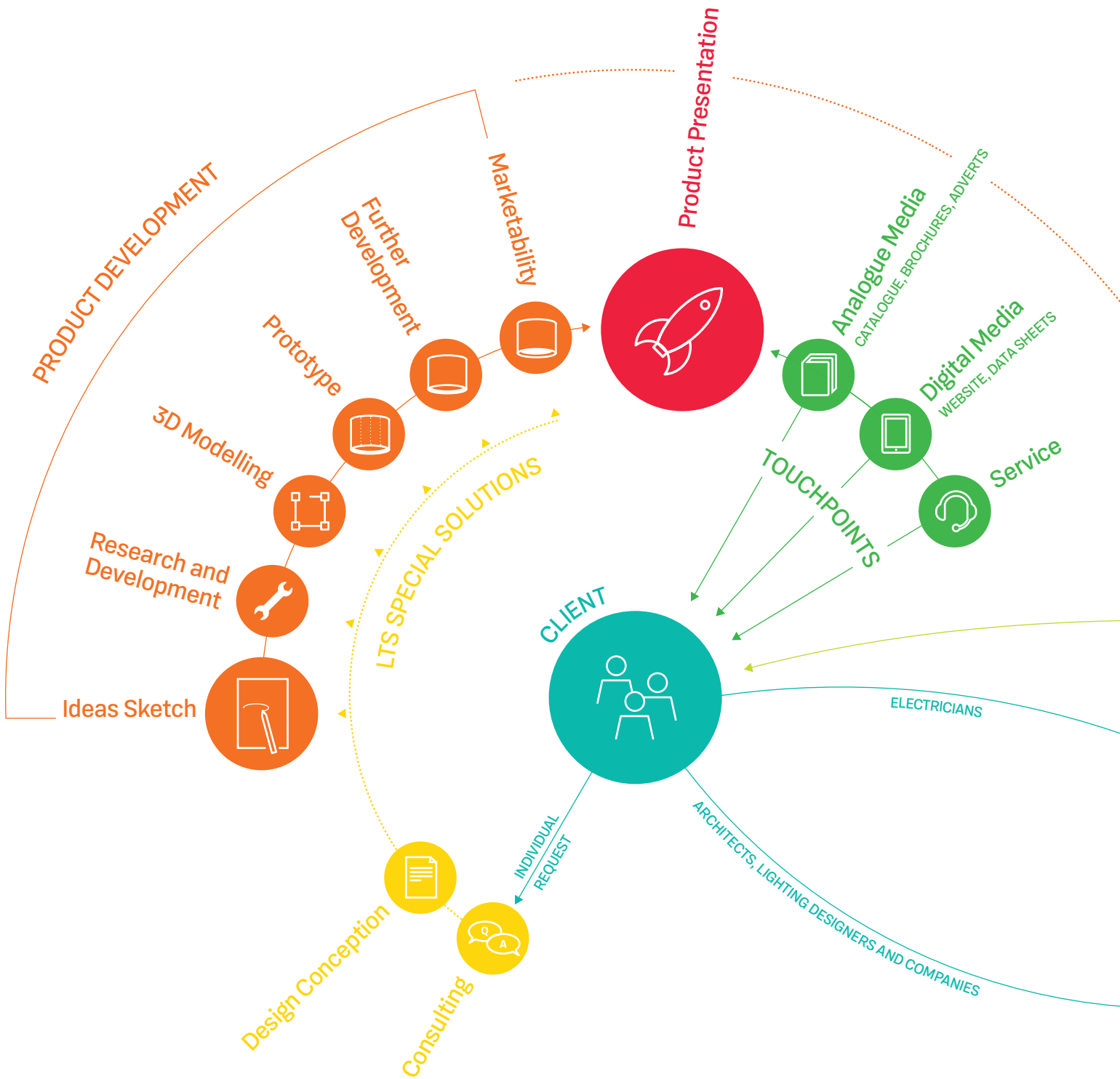

# HOW WE WORK

**THE LTS PRODUCT CYCLE**  
FROM THE IDEA TO DELIVERY

**The client takes centre stage**

Our sales representatives or expert in-house service team represent the interface between our clients and the LTS products. We provide holistic lighting solutions in accordance with our high-quality standard products. Of course, you can purchase these directly from LTS or via our partners in the electrical wholesale trade.

**Up-to-date information across all networks**

Our new website offers information for every product. This is where you will find media and digital data sheets which are also available for download. Moreover, our configurators support you in quickly and easily creating individual lighting solutions according to your given requirements.

**All products are "Made in Germany"**

From the idea, to first sketches, all the way through to a marketable standard product, the entire product development takes place in-house at LTS. Numerous utility model specifications and patents document the success of our research and development. High-tech machinery ensures independence in production, while all the process steps in assembly are carried out manually.

**LTS special solutions made to measure**

We can also address individual requests. The high vertical range of manufacture at the Tett nang location enables flexible adjustment and a quick response time.

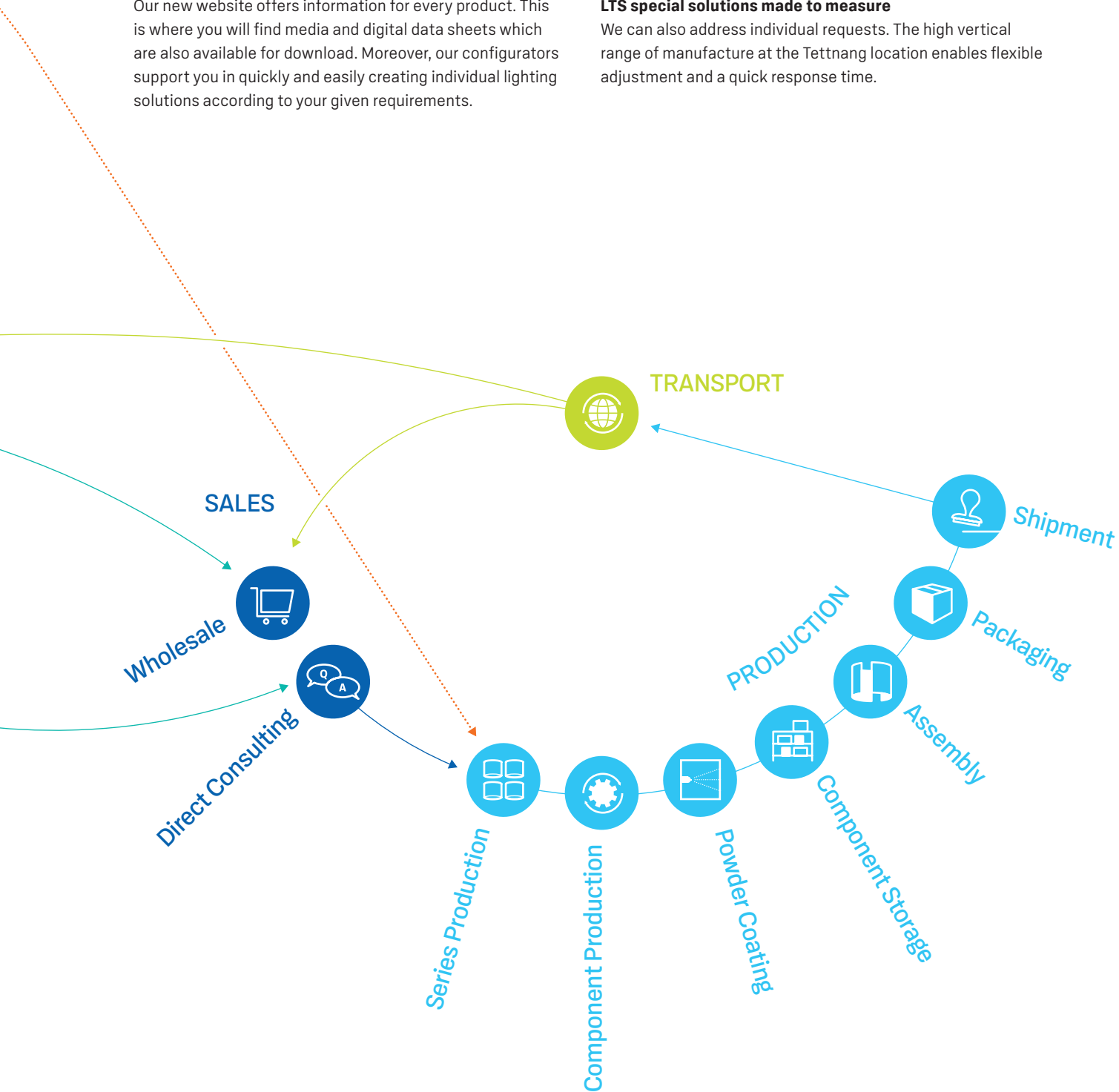

# CURTAIN UP FOR OUR PRODUCTS



LTS  
LOVE TO SHINE

# Product Range

## Track-Mounted Spotlights

---

**Bixx 100**  
38



**BixxL 200**  
40



**EuroLED**  
42



**Jamie 200**  
44



**Jamie 300**  
46



---

**Jett 100**  
48



**Scout Next**  
50



**Torpedo 200**  
52



**Torpedo 300**  
54



## Recessed Spotlights

---

**CSA 40**  
58



**CSA 50**  
60



**CSA 60**  
62



**CSA 72 Round**  
64



**Dallton XSmall**  
66



---

**Dallton Small**  
68



**Dallton Medium**  
70



**Dallton Large**  
72



**Scene 1 System**  
76



**Scene 33 System**  
78



---

**Scene 4**  
80



**Vale-Tu Round  
Small/Medium**  
82



**Vale-Tu Round  
XSmall**  
84



**Vale-Tu Square  
Small/Medium**  
86



**Vale-Tu Square  
XSmall**  
88



---

**Vario Classic**  
90



# Product Range

## Surface-Mounted Downlights

---

**Button 300**  
94



**Button Mini 100/200**  
96



## Recessed Downlights

---

**Flixx 100/200 Round**  
100



**Flixx 100/200 Square**  
102



**Flixx 300 Flat Round**  
104



**Flixx 300/400 Round**  
106



**Flixx 300/400 Square**  
108



---

**Flixx 320 Round Wallwasher**  
110



**Torpedo 250**  
112



**Torpedo 350**  
114



**Vale-Tu Flat**  
116



## Lighting Systems

---

**StraitLine 60**  
120



**StraitLine 60 Spot**  
122





## Ceiling & Pendant Luminaires

**Lunata Direct-Indirect with Light Effect Ring**  
126



**Lunata Direct without Light Effect Ring**  
128



**LUZ Surface-Mounted**  
130



**LUZ Recessed Standard**  
132



**LUZ Pendant**  
134



**LUZ Track-Mounted**  
136



**LUZ Track-Mounted Pendant**  
138



**Monoline 070 Surface-Mounted & Pendant**  
140



**Piano Pendant**  
144



**PL 20 Surface-Mounted & Pendant**  
146



**PL 22 Surface-Mounted & Pendant**  
148



**PL 25 Recessed Trimless**  
150



**PL 26 Direct-Indirect Surface-Mounted**  
152



**PL 27 Recessed**  
154



**PL 28 Direct-Indirect Pendant**  
156



**PL 50 Surface-Mounted & Pendant**  
158



**PL 52 Surface-Mounted & Pendant**  
160



**PL 55 Recessed Trimless**  
162



**PL 57 Recessed**  
164



**Trentino II Ceiling**  
166



## Product Range

### Ceiling & Pendant Luminaires

---

**Trentino II  
Pendant**  
168



### Free-Standing Luminaires

---

**Ascona**  
172



**Piano Stand**  
174



**Trentino II Stand**  
176



### Wall Luminaires

---

**LUZ Wall**  
180



**PL 23 Wall**  
182



## Insert Luminaires

---

**Fyrra**  
186



**Optico**  
188



## High-Bay Luminaires

---

**FLC**  
192



## Contact Tracks & Accessoires

---

**ONETrack  
Surface-Mounted**  
198



**ONETrack  
Recessed**  
200





# TRACK- MOUNTED SPOTLIGHTS

[www.lts-light.com/track-mounted-spotlights](http://www.lts-light.com/track-mounted-spotlights)





# Bixx 100



**Note**  
 Also available as high-power spotlight BixxL 200 (page 40)

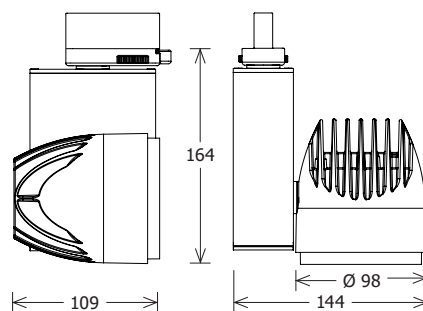

**Standard options**

|        |        |      |      |        |
|--------|--------|------|------|--------|
| 2700 K | BAKERY | MEAT | DALI | BLACK  |
| 4000 K |        |      |      | SILVER |
|        |        |      |      | WHITE  |

**Special options**

|        |              |     |           |         |         |     |
|--------|--------------|-----|-----------|---------|---------|-----|
| 3500 K | CRI 90 SDCM3 | TWL | MinusBlue | FASHION | PRODUCE | RAL |
|--------|--------------|-----|-----------|---------|---------|-----|





Jacques' Wein-Depot, Aachen, GER · Planning: D.S.D.5 Planungsgesellschaft · Photo: Max Schulz

## Range selection



| Article name     | Beam angle | CCT [K] | System power [W] | Luminous flux [lm] | EEC  |
|------------------|------------|---------|------------------|--------------------|------|
| BIXX 102.30.15.2 | 15°        | 3000    | 27               | 2710               | A+ → |
| BIXX 102.30.25.2 | 25°        | 3000    | 27               | 2700               | A+ → |
| BIXX 102.30.35.2 | 35°        | 3000    | 27               | 2680               | A+ → |
| BIXX 102.30.50.2 | 50°        | 3000    | 27               | 2620               | A+ → |
| BIXX 103.30.15.2 | 15°        | 3000    | 35               | 3220               | A+ → |
| BIXX 103.30.25.2 | 25°        | 3000    | 35               | 3200               | A+ → |
| BIXX 103.30.35.2 | 35°        | 3000    | 35               | 3180               | A+ → |
| BIXX 103.30.50.2 | 50°        | 3000    | 35               | 3120               | A+ → |

## Accessories

| Article name | Description   |
|--------------|---|
| FOCUS 100.1  | superior optic with focusable biconvex lens for accent lighting |
| ZBK 96       | anti-glare flaps  |
| ZBW83        | honeycomb louvre  |



Further product informations you will find under [www.lts-light.eu/2311](http://www.lts-light.eu/2311)

# BixxL 200

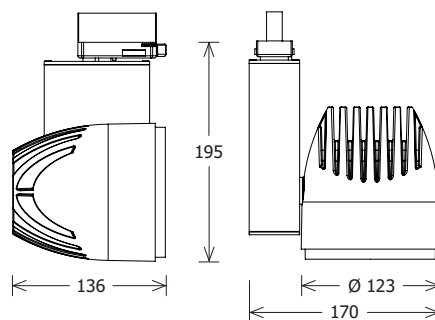

**Standard options**



**Special options**







Porsche Zentrum, Paderborn, GER · Photo: Henning Stauch Photography

## Range selection



| Article name      | Beam angle | CCT [K] | System power [W] | Luminous flux [lm] | EEC |
|-------------------|------------|---------|------------------|--------------------|-----|
| BIXXL 205.30.15.2 | 15°        | 3000    | 51               | 5200               | A++ |
| BIXXL 205.30.25.2 | 25°        | 3000    | 51               | 5180               | A++ |
| BIXXL 205.30.40.2 | 40°        | 3000    | 51               | 5060               | A+  |
| BIXXL 205.30.60.2 | 60°        | 3000    | 51               | 5240               | A++ |
| BIXXL 206.30.15.2 | 15°        | 3000    | 59               | 5830               | A+  |
| BIXXL 206.30.25.2 | 25°        | 3000    | 59               | 5810               | A+  |
| BIXXL 206.30.40.2 | 40°        | 3000    | 59               | 5680               | A+  |
| BIXXL 206.30.60.2 | 60°        | 3000    | 59               | 5870               | A+  |
| BIXXL 207.30.15.2 | 15°        | 3000    | 68               | 6940               | A++ |
| BIXXL 207.30.25.2 | 25°        | 3000    | 68               | 6920               | A++ |
| BIXXL 207.30.40.2 | 40°        | 3000    | 68               | 6790               | A+  |
| BIXXL 207.30.60.2 | 60°        | 3000    | 68               | 6980               | A++ |

## Accessories

| Article name | Description      |
|--------------|------------------|
| ZBK 98       | anti-glare flaps |
| ZBW 84       | honeycomb louvre |



Further product informations you will find under [www.lts-light.eu/2318](http://www.lts-light.eu/2318)

# EuroLED

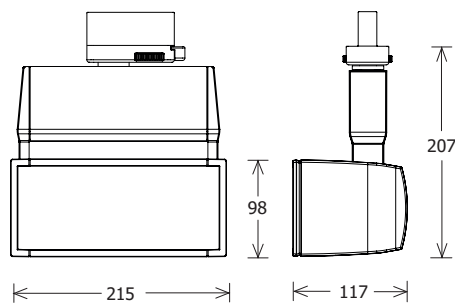

**Standard options**

|        |        |      |      |                          |
|--------|--------|------|------|--------------------------|
| 4000 K | BAKERY | MEAT | DALI | BLACK<br>SILVER<br>WHITE |
|--------|--------|------|------|--------------------------|

**Special options**

|                  |                        |           |         |         |     |
|------------------|------------------------|-----------|---------|---------|-----|
| 2700 K<br>3500 K | <b>CRI 90</b><br>SDCM3 | MinusBlue | FASHION | PRODUCE | RAL |
|------------------|------------------------|-----------|---------|---------|-----|





RaumW Einrichten, Kirchzarten, GER · Planning: RaumW · Photo: Enrique Salcedo Puerto

## Range selection



| Article name | Fixing                 | CCT [K] | System power [W] | Luminous flux [lm] | Weight [kg] | EEC |
|--------------|------------------------|---------|------------------|--------------------|-------------|-----|
| EL 303.30.2  | track-mounted          | 3000    | 34               | 4220               | 2.12        | A++ |
| EL 304.30.2  | track-mounted          | 3000    | 50               | 6280               | 2.12        | A++ |
| EL 307.30.2  | track-mounted          | 3000    | 59               | 7420               | 2.02        | A++ |
| EL 303.30.4  | surface-mounted        | 3000    | 34               | 4220               | 2.44        | A++ |
| EL 304.30.4  | surface-mounted        | 3000    | 50               | 6280               | 2.44        | A++ |
| EL 303.30.5  | tube-mounted (Ø 50 mm) | 3000    | 34               | 4220               | 2.56        | A++ |
| EL 304.30.5  | tube-mounted (Ø 50 mm) | 3000    | 50               | 6280               | 2.56        | A++ |
| EL 307.30.5  | tube-mounted (Ø 50 mm) | 3000    | 59               | 7420               | 2.42        | A++ |

## Accessories

| Article name | Description      |
|--------------|------------------|
| ZBK 97       | anti-glare flaps |



Further product informations you will find under [www.lts-light.eu/2322](http://www.lts-light.eu/2322)

# Jamie 200

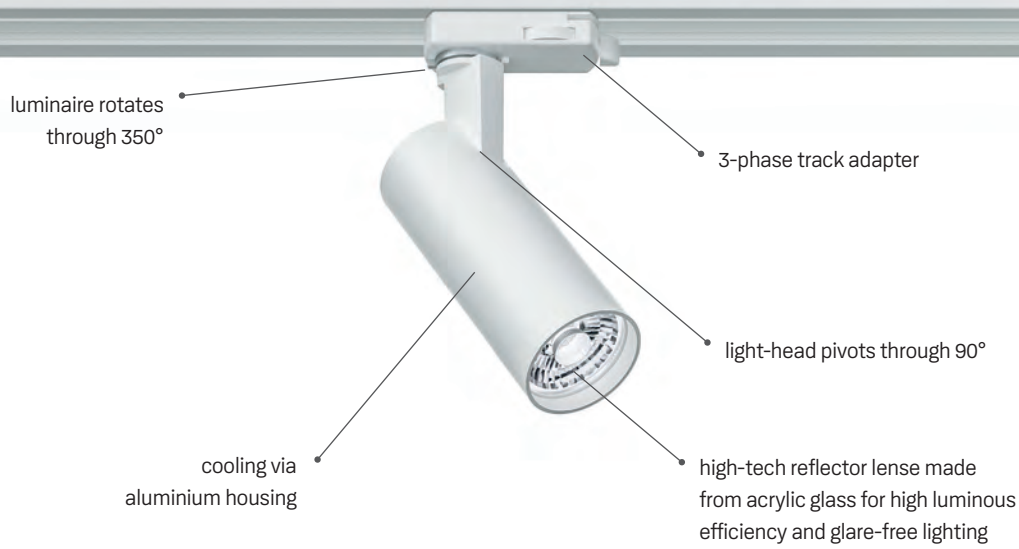

**Note**  
Also available as larger version Jamie 300 (page 46).

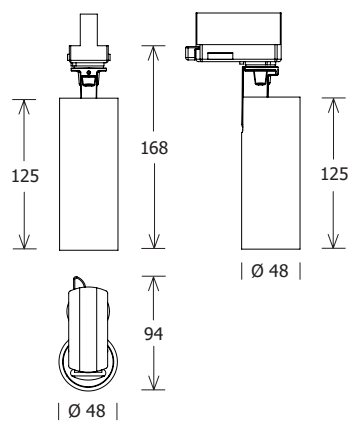

**Standard options**

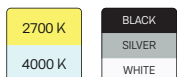

**Special options**

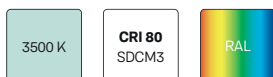





Weltladen, Ravensburg, GER · Photo: Jean-Marc Delette – Photography

## Range selection



| Article name       | Beam angle | CCT [K] | System power [W] | Luminous flux [lm] | EEC |
|--------------------|------------|---------|------------------|--------------------|-----|
| JAMIE 201.930.25.2 | 25°        | 3000    | 12               | 930                | A+  |
| JAMIE 201.930.40.2 | 40°        | 3000    | 12               | 980                | A+  |
| JAMIE 201.930.55.2 | 55°        | 3000    | 12               | 680                | A   |

Further product informations you will find under [www.lts-light.eu/2365](http://www.lts-light.eu/2365)

# Jamie 300

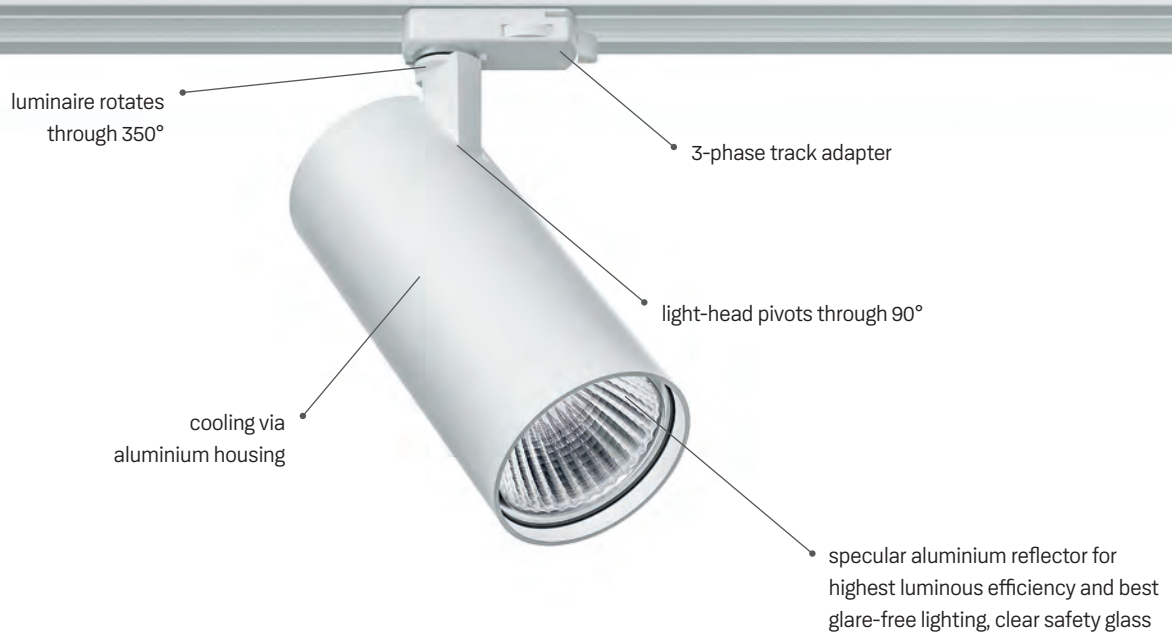

**Note**  
**Also available as smaller**  
**version Jamie 200 (page 44).**

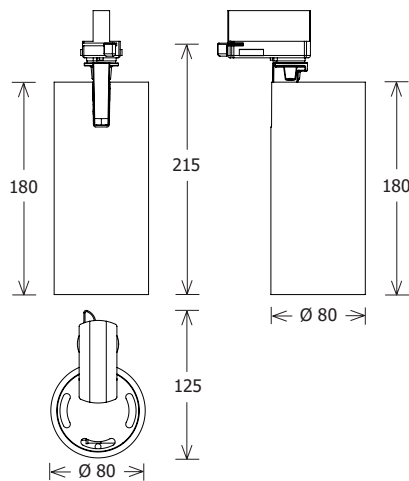

**Standard options**

|        |      |        |
|--------|------|--------|
| 2700 K | DALI | BLACK  |
| 4000 K |      | SILVER |
|        |      | WHITE  |

**Special options**

|        |                 |           |         |     |
|--------|-----------------|-----------|---------|-----|
| 3500 K | CRI 80<br>SDCM3 | MinusBlue | FASHION | RAL |
|--------|-----------------|-----------|---------|-----|





Wolford, Amsterdam, NL · Photo: Maarten Willemstein Photography

## Range selection



| Article name       | Beam angle | CCT [K] | System power [W] | Luminous flux [lm] | EEC |
|--------------------|------------|---------|------------------|--------------------|-----|
| JAMIE 301.930.15.2 | 15°        | 3000    | 16               | 1380               | A+  |
| JAMIE 301.930.25.2 | 25°        | 3000    | 16               | 1390               | A+  |
| JAMIE 301.930.35.2 | 35°        | 3000    | 16               | 1340               | A+  |
| JAMIE 301.930.45.2 | 45°        | 3000    | 16               | 1300               | A+  |
| JAMIE 302.930.15.2 | 15°        | 3000    | 26               | 2360               | A+  |
| JAMIE 302.930.25.2 | 25°        | 3000    | 26               | 2390               | A+  |
| JAMIE 302.930.35.2 | 35°        | 3000    | 26               | 2330               | A+  |
| JAMIE 302.930.45.2 | 45°        | 3000    | 26               | 2200               | A+  |

## Accessories

| Article name | Description      |
|--------------|------------------|
| ZBW 85       | honeycomb louvre |

Further product informations you will find under [www.its-light.eu/2366](http://www.its-light.eu/2366)

# Jett 100

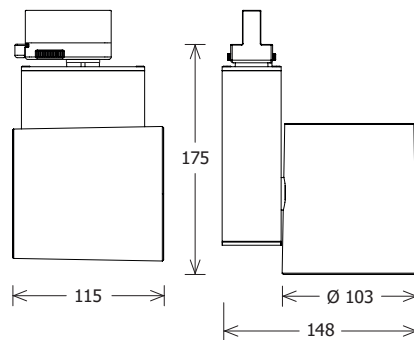
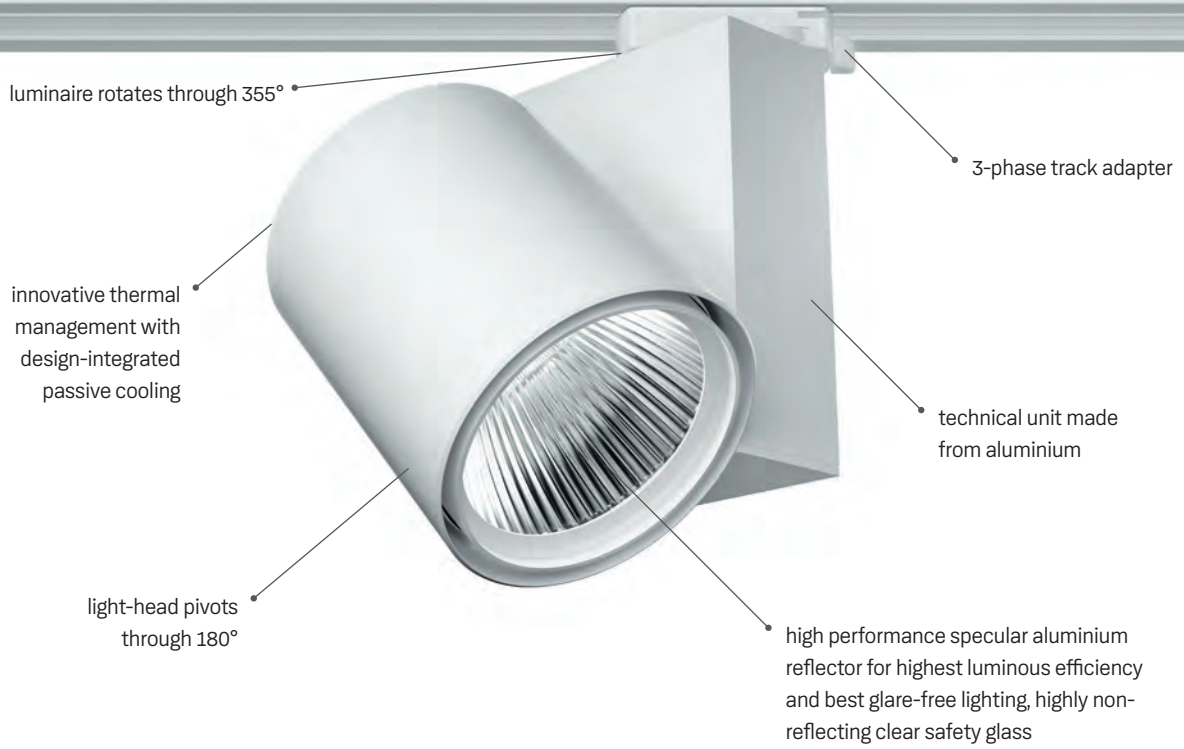

**Standard options**

|        |        |      |      |        |
|--------|--------|------|------|--------|
| 2700 K | BAKERY | MEAT | DALI | BLACK  |
| 4000 K |        |      |      | SILVER |
|        |        |      |      | WHITE  |

**Special options**

|        |                        |     |      |           |         |         |     |     |
|--------|------------------------|-----|------|-----------|---------|---------|-----|-----|
| 3500 K | <b>CR1 90</b><br>SDCM3 | TWL | TWPI | MinusBlue | FASHION | PRODUCE | 15° | RAL |
|--------|------------------------|-----|------|-----------|---------|---------|-----|-----|





Tafelzier, Nuremberg, GER · Planning: toc. designstudio · Photo: toc. designstudio

## Range selection



| Article name     | Beam angle | CCT [K] | System power [W] | Luminous flux [lm] | EEC |
|------------------|------------|---------|------------------|--------------------|-----|
| JETT 102.30.25.2 | 25°        | 3000    | 20               | 2420               | A++ |
| JETT 102.30.35.2 | 35°        | 3000    | 20               | 2330               | A++ |
| JETT 102.30.50.2 | 50°        | 3000    | 20               | 2180               | A++ |
| JETT 103.30.25.2 | 25°        | 3000    | 30               | 3290               | A++ |
| JETT 103.30.35.2 | 35°        | 3000    | 30               | 3220               | A++ |
| JETT 103.30.50.2 | 50°        | 3000    | 30               | 2990               | A+  |
| JETT 104.30.25.2 | 25°        | 3000    | 40               | 4620               | A++ |
| JETT 104.30.35.2 | 35°        | 3000    | 40               | 4480               | A++ |
| JETT 104.30.50.2 | 50°        | 3000    | 40               | 4190               | A++ |
| JETT 105.30.25.2 | 25°        | 3000    | 50               | 5530               | A++ |
| JETT 105.30.35.2 | 35°        | 3000    | 50               | 5470               | A++ |
| JETT 105.30.50.2 | 50°        | 3000    | 50               | 5020               | A+  |

## Accessories

| Article name | Description   |
|--------------|---|
| FOCUS 100.1  | superior optic with focusable biconvex lens for accent lighting |
| ZBK 96       | anti-glare flaps  |
| ZBW 83       | honeycomb louvre  |



Further product informations you will find under [www.lts-light.eu/2319](http://www.lts-light.eu/2319)

# Scout Next

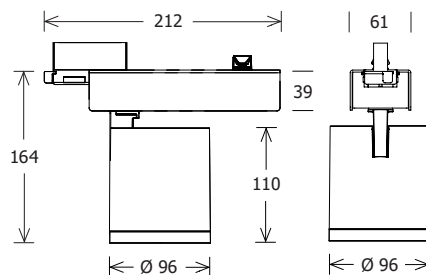
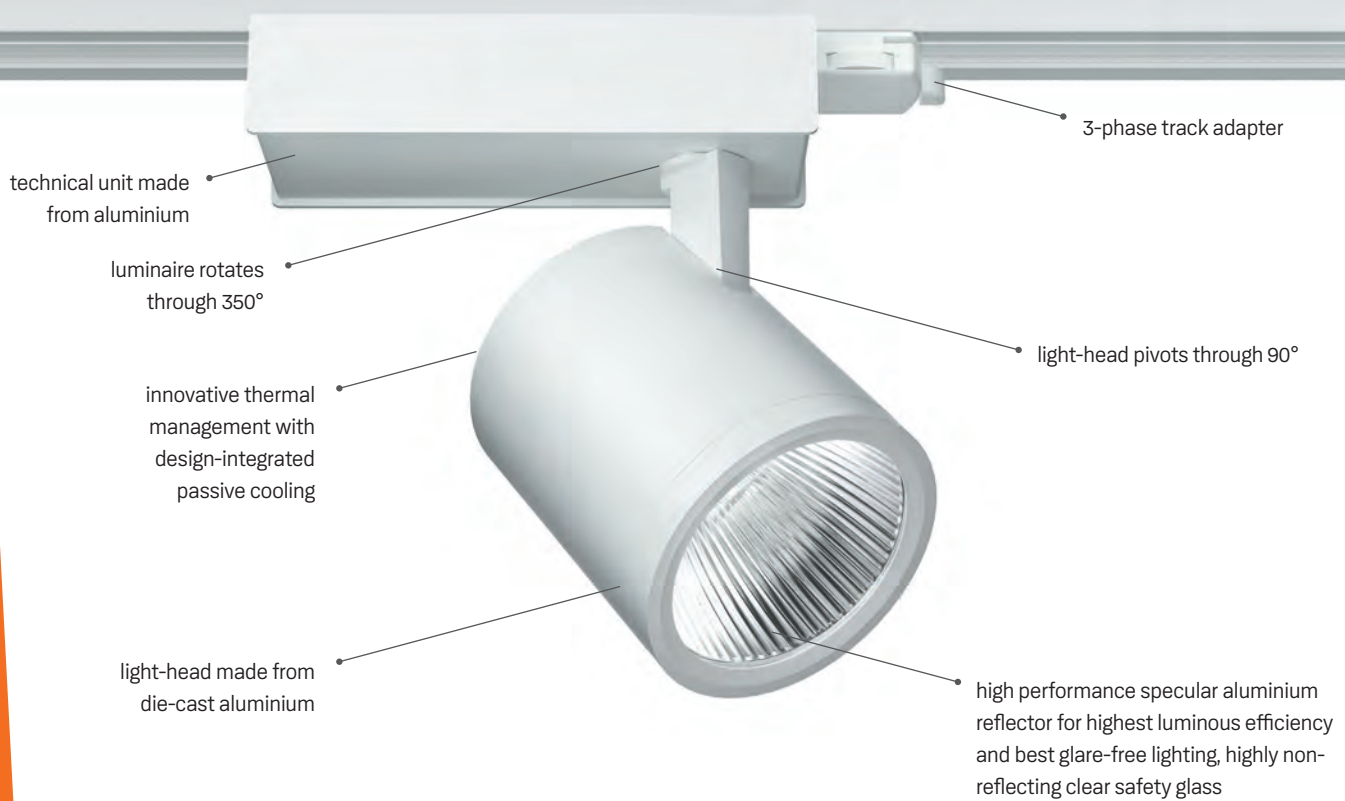

**Standard options**

|        |        |      |         |      |        |
|--------|--------|------|---------|------|--------|
| 2700 K | BAKERY | MEAT | PRODUCE | DALI | BLACK  |
| 4000 K |        |      |         |      | SILVER |
|        |        |      |         |      | WHITE  |

**Special options**

|        |              |     |      |           |         |     |
|--------|--------------|-----|------|-----------|---------|-----|
| 3500 K | CRI 80 SDCM3 | TWL | TWPI | MinusBlue | FASHION | RAL |
|--------|--------------|-----|------|-----------|---------|-----|



Bauermarkt, Ravensburg, GER · Photo: Jean-Marc Delettre – Photography

## Range selection



| Article name       | Beam angle | CCT [K] | System power [W] | Luminous flux [lm] | EEC |
|--------------------|------------|---------|------------------|--------------------|-----|
| SCOUT 202.930.25.2 | 25°        | 3000    | 22               | 2410               | A++ |
| SCOUT 202.930.35.2 | 35°        | 3000    | 22               | 2320               | A++ |
| SCOUT 202.930.50.2 | 50°        | 3000    | 22               | 2310               | A++ |
| SCOUT 203.930.25.2 | 25°        | 3000    | 30               | 3380               | A++ |
| SCOUT 203.930.35.2 | 35°        | 3000    | 30               | 3270               | A++ |
| SCOUT 203.930.50.2 | 50°        | 3000    | 30               | 3240               | A++ |
| SCOUT 204.930.25.2 | 25°        | 3000    | 39               | 4310               | A++ |
| SCOUT 204.930.35.2 | 35°        | 3000    | 39               | 4190               | A++ |
| SCOUT 204.930.50.2 | 50°        | 3000    | 39               | 4140               | A++ |
| SCOUT 205.930.25.2 | 25°        | 3000    | 48               | 5190               | A++ |
| SCOUT 205.930.35.2 | 35°        | 3000    | 48               | 5050               | A++ |
| SCOUT 205.930.50.2 | 50°        | 3000    | 48               | 4990               | A++ |

## Accessories

| Article name | Description   |
|--------------|---|
| FOCUS 100.1  | superior optic with focusable biconvex lens for accent lighting (does not apply for SCOUT 205...) |

Further product informations you will find under [www.its-light.eu/2367](http://www.its-light.eu/2367)



# Torpedo 200

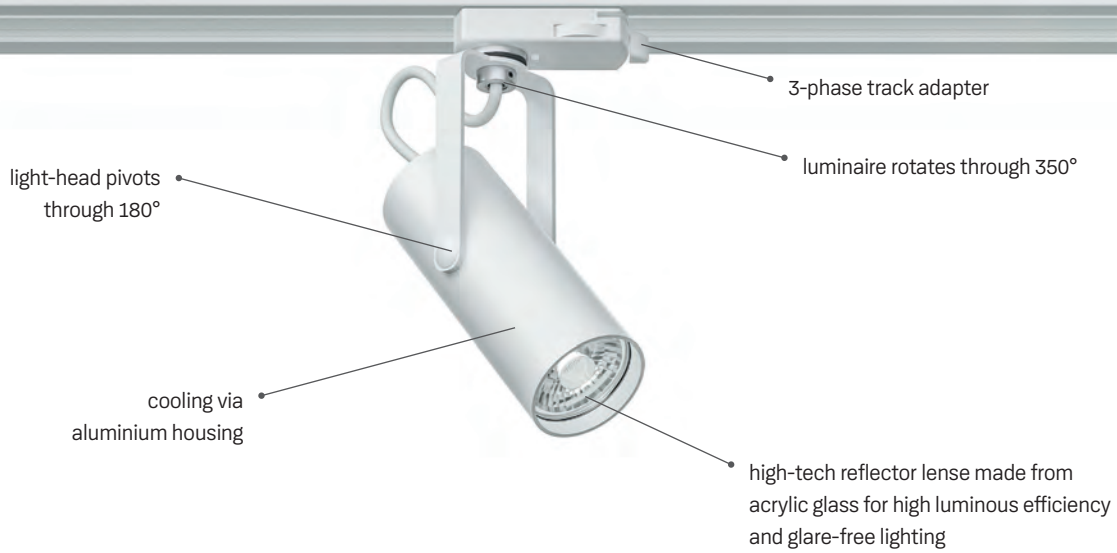

**Note**  
Also available as larger  
version Torpedo 300 (page 54).

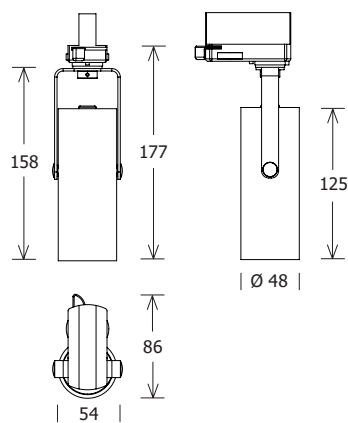

**Standard options**

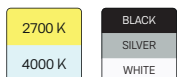

**Special options**

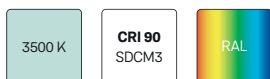



Douglas, Vienna, AUT · Planning: Volker Metz · Photo: KiTO.photography

## Range selection



| Article name      | Beam angle | CCT [K] | System power [W] | Luminous flux [lm] | EEC |
|-------------------|------------|---------|------------------|--------------------|-----|
| TORL 201.830.25.2 | 25°        | 3000    | 12               | 1030               | A+  |
| TORL 201.830.40.2 | 40°        | 3000    | 12               | 1100               | A+  |
| TORL 201.830.55.2 | 55°        | 3000    | 12               | 760                | A   |

Further product informations you will find under [www.lts-light.eu/2364](http://www.lts-light.eu/2364)



# Torpedo 300

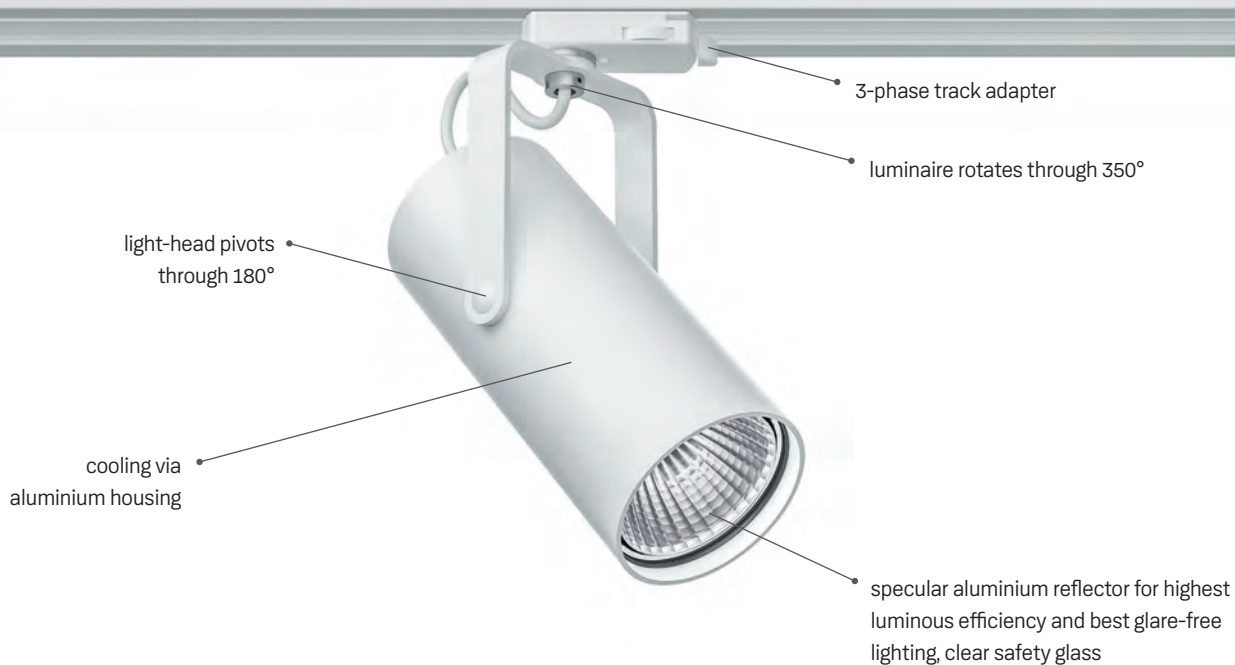

**Note**  
**Also available as smaller version**  
**Torpedo 200 (page 52).**

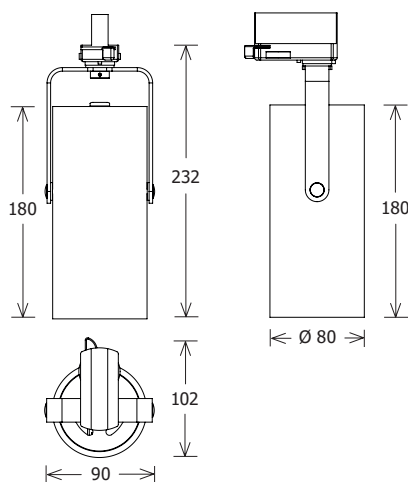

**Standard options**

|        |      |        |
|--------|------|--------|
| 2700 K | DALI | BLACK  |
| 4000 K |      | SILVER |
|        |      | WHITE  |

**Special options**

|        |                 |           |         |     |
|--------|-----------------|-----------|---------|-----|
| 3500 K | CRI 90<br>SDCM3 | MinusBlue | FASHION | RAL |
|--------|-----------------|-----------|---------|-----|



Cucina Fabbrica, Wolfurt, AUT · Photo: Jean-Marc Delettre — Photography

## Range selection



| Article name      | Beam angle | CCT [K] | System power [W] | Luminous flux [lm] | EEC |
|-------------------|------------|---------|------------------|--------------------|-----|
| TORL 301.830.15.2 | 15°        | 3000    | 13               | 1320               | A++ |
| TORL 301.830.25.2 | 25°        | 3000    | 13               | 1320               | A++ |
| TORL 301.830.35.2 | 35°        | 3000    | 13               | 1310               | A+  |
| TORL 301.830.45.2 | 45°        | 3000    | 13               | 1290               | A+  |
| TORL 302.830.15.2 | 15°        | 3000    | 26               | 2630               | A++ |
| TORL 302.830.25.2 | 25°        | 3000    | 26               | 2620               | A+  |
| TORL 302.830.35.2 | 35°        | 3000    | 26               | 2610               | A+  |
| TORL 302.830.45.2 | 45°        | 3000    | 26               | 2580               | A+  |

## Accessories

| Article name | Description      |
|--------------|------------------|
| ZBW 85       | honeycomb louvre |

Further product informations you will find under [www.lts-light.eu/2363](http://www.lts-light.eu/2363)

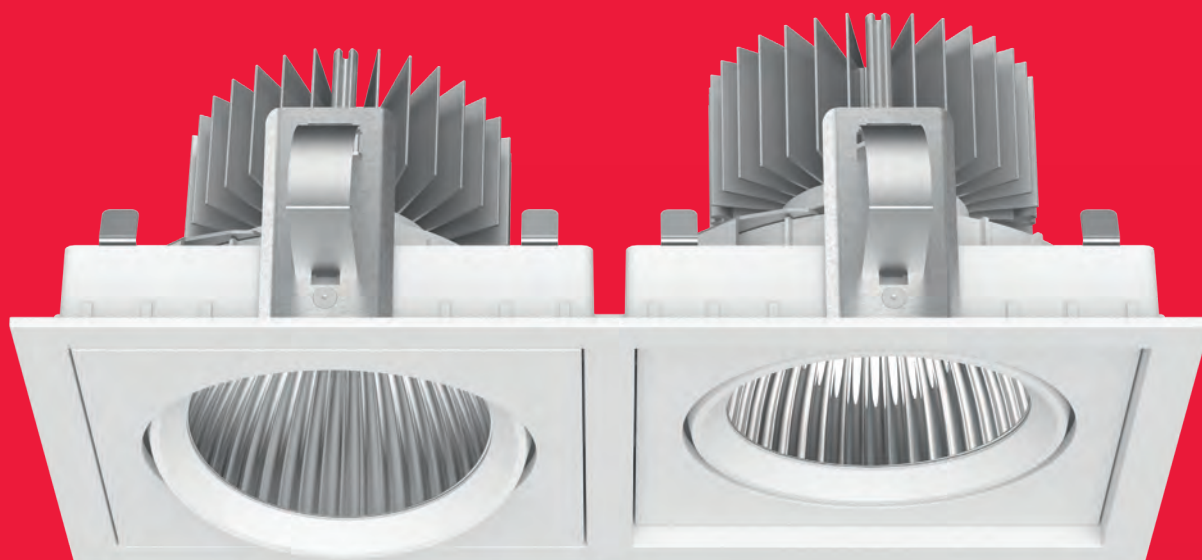

# RECESSED SPOTLIGHTS

[www.lts-light.com/recessed-spotlights](http://www.lts-light.com/recessed-spotlights)





# CSA 40

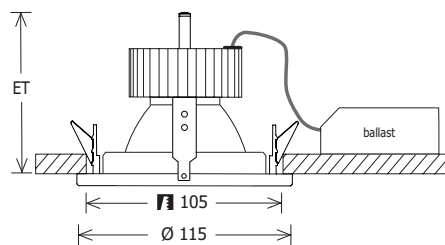
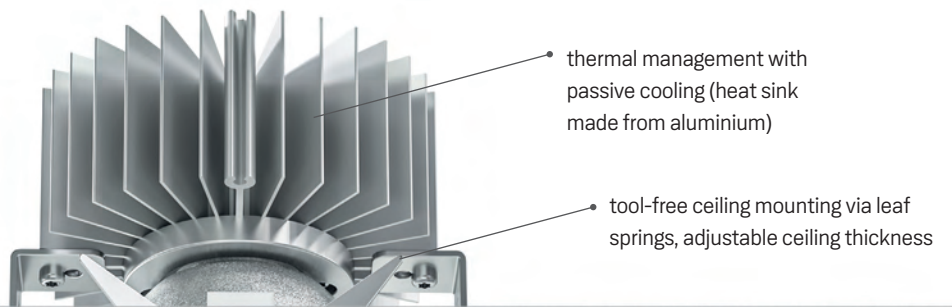

Standard options

|        |      |        |
|--------|------|--------|
| 2700 K | ▲    | SILVER |
| 4000 K | DALI | WHITE  |

Special options

|        |                 |     |      |           |         |                   |       |
|--------|-----------------|-----|------|-----------|---------|-------------------|-------|
| 3500 K | CRI 90<br>SDCM3 | TWL | TWPI | MinusBlue | FASHION | CONCRETE RECESSED | BLACK |
|--------|-----------------|-----|------|-----------|---------|-------------------|-------|





UNIQLO, London, GB · Photo: HUFTON + CROW

## Range selection



| Article name     | Beam angle | CCT [K] | System power [W] | Luminous flux [lm] | Installation depth [mm] | Cut-out [mm] | Ceiling thickness [mm] | Weight [kg] | EEC |
|------------------|------------|---------|------------------|--------------------|-------------------------|--------------|------------------------|-------------|-----|
| CSALP 40.1030.15 | 15°        | 3000    | 14               | 1430               | 105                     | Ø 105        | 3 - 25                 | 0.56        | A++ |
| CSALP 40.1030.25 | 25°        | 3000    | 14               | 1420               | 105                     | Ø 105        | 3 - 25                 | 0.56        | A++ |
| CSALP 40.1030.35 | 35°        | 3000    | 14               | 1410               | 105                     | Ø 105        | 3 - 25                 | 0.56        | A+  |
| CSALP 40.1030.50 | 50°        | 3000    | 14               | 1390               | 105                     | Ø 105        | 3 - 25                 | 0.56        | A+  |
| CSALP 40.2030.15 | 15°        | 3000    | 27               | 2740               | 105                     | Ø 105        | 3 - 25                 | 0.70        | A++ |
| CSALP 40.2030.25 | 25°        | 3000    | 27               | 2730               | 105                     | Ø 105        | 3 - 25                 | 0.70        | A++ |
| CSALP 40.2030.35 | 35°        | 3000    | 27               | 2710               | 105                     | Ø 105        | 3 - 25                 | 0.70        | A+  |
| CSALP 40.2030.50 | 50°        | 3000    | 27               | 2650               | 105                     | Ø 105        | 3 - 25                 | 0.70        | A+  |
| CSALP 40.3030.15 | 15°        | 3000    | 36               | 3640               | 122                     | Ø 105        | 3 - 25                 | 0.72        | A++ |
| CSALP 40.3030.25 | 25°        | 3000    | 36               | 3620               | 122                     | Ø 105        | 3 - 25                 | 0.72        | A+  |
| CSALP 40.3030.35 | 35°        | 3000    | 36               | 3600               | 122                     | Ø 105        | 3 - 25                 | 0.72        | A+  |
| CSALP 40.3030.50 | 50°        | 3000    | 36               | 3530               | 122                     | Ø 105        | 3 - 25                 | 0.72        | A+  |

Further product informations you will find under [www.its-light.eu/2122](http://www.its-light.eu/2122)



# CSA 50

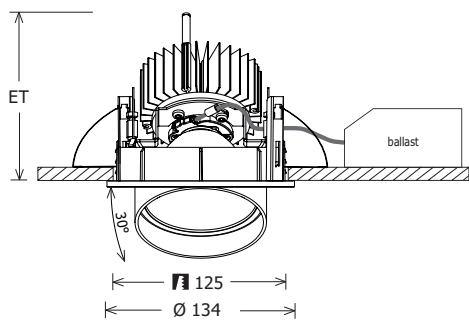
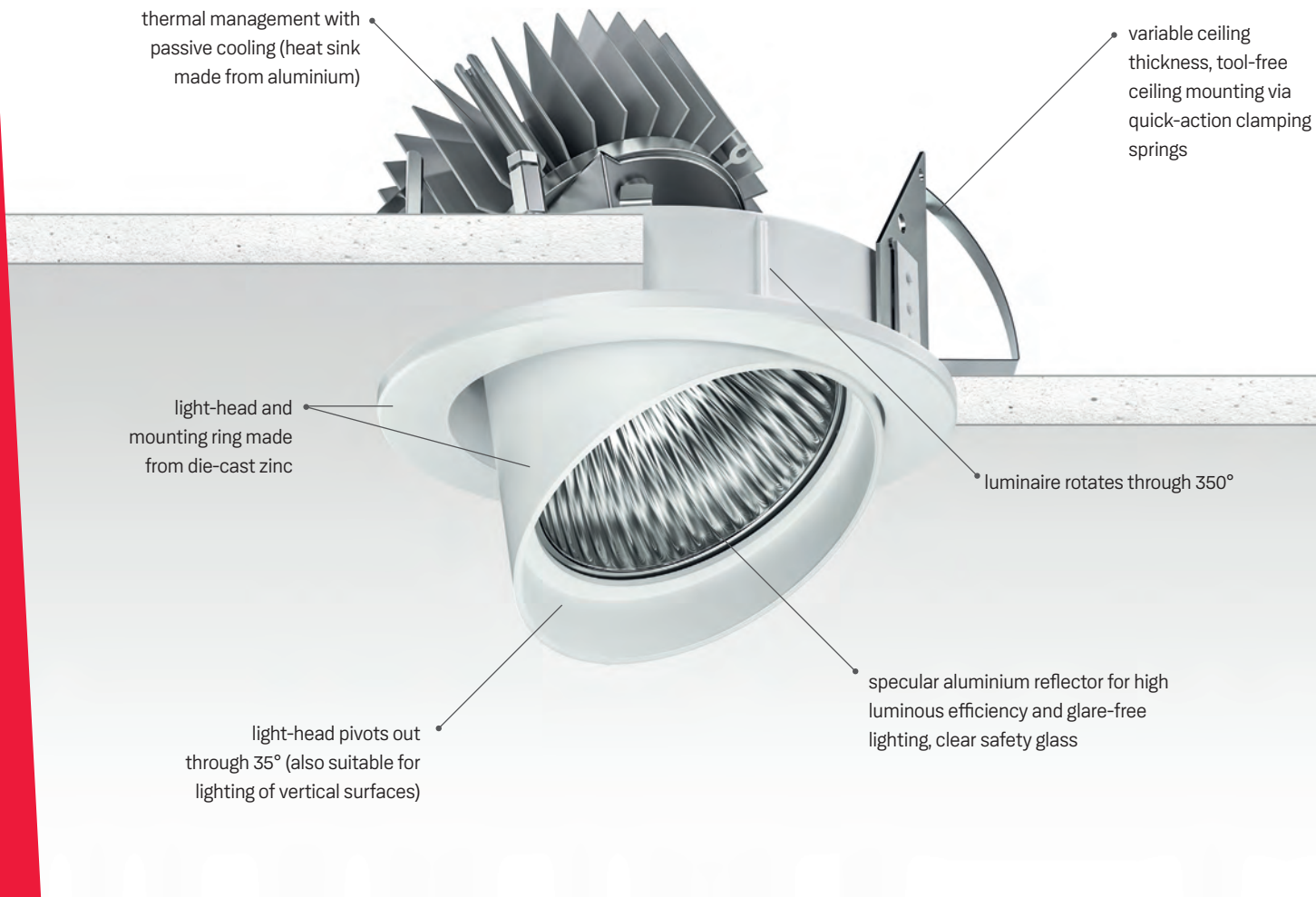

Standard options

|        |      |        |
|--------|------|--------|
| 2700 K | DALI | SILVER |
| 4000 K |      | WHITE  |

Special options

|        |              |     |      |           |         |        |      |         |                   |       |
|--------|--------------|-----|------|-----------|---------|--------|------|---------|-------------------|-------|
| 3500 K | CRI 90 SDCM3 | TWL | TWPI | MinusBlue | FASHION | BAKERY | MEAT | PRODUCE | CONCRETE RECESSED | BLACK |
|--------|--------------|-----|------|-----------|---------|--------|------|---------|-------------------|-------|



Modehaus Fischer, Singen, GER



## Range selection

| Article name     | Beam angle | CCT [K] | System power [W] | Luminous flux [lm] | Installation depth [mm] | Cut-out [mm] | Ceiling thickness [mm] | Weight [kg] | EEC |
|------------------|------------|---------|------------------|--------------------|-------------------------|--------------|------------------------|-------------|-----|
| CSALP 50.1030.15 | 15°        | 3000    | 14               | 1410               | 139                     | Ø 125        | 1 - 25                 | 1.20        | A+  |
| CSALP 50.1030.25 | 25°        | 3000    | 14               | 1400               | 139                     | Ø 125        | 1 - 25                 | 1.20        | A+  |
| CSALP 50.1030.35 | 35°        | 3000    | 14               | 1390               | 139                     | Ø 125        | 1 - 25                 | 1.20        | A+  |
| CSALP 50.1030.50 | 50°        | 3000    | 14               | 1370               | 139                     | Ø 125        | 1 - 25                 | 1.20        | A+  |
| CSALP 50.2030.15 | 15°        | 3000    | 27               | 2710               | 139                     | Ø 125        | 1 - 25                 | 1.24        | A+  |
| CSALP 50.2030.25 | 25°        | 3000    | 27               | 2700               | 139                     | Ø 125        | 1 - 25                 | 1.24        | A+  |
| CSALP 50.2030.35 | 35°        | 3000    | 27               | 2680               | 139                     | Ø 125        | 1 - 25                 | 1.24        | A+  |
| CSALP 50.2030.50 | 50°        | 3000    | 27               | 2620               | 139                     | Ø 125        | 1 - 25                 | 1.24        | A+  |
| CSALP 50.3030.15 | 15°        | 3000    | 36               | 3600               | 139                     | Ø 125        | 1 - 25                 | 1.24        | A+  |
| CSALP 50.3030.25 | 25°        | 3000    | 36               | 3580               | 139                     | Ø 125        | 1 - 25                 | 1.24        | A+  |
| CSALP 50.3030.35 | 35°        | 3000    | 36               | 3560               | 139                     | Ø 125        | 1 - 25                 | 1.24        | A+  |
| CSALP 50.3030.50 | 50°        | 3000    | 36               | 3490               | 139                     | Ø 125        | 1 - 25                 | 1.24        | A+  |

## Accessories

| Article name     | Description  |
|------------------|--|
| ZDAR 125.145-205 | spacing ring for ceiling cut-outs from 145 to 205 mm |

Further product informations you will find under [www.lts-light.eu/2353](http://www.lts-light.eu/2353)

# CSA 60

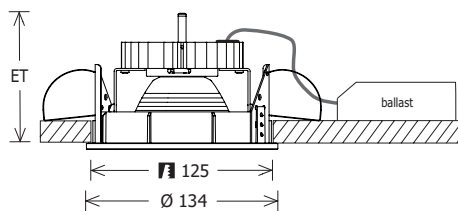
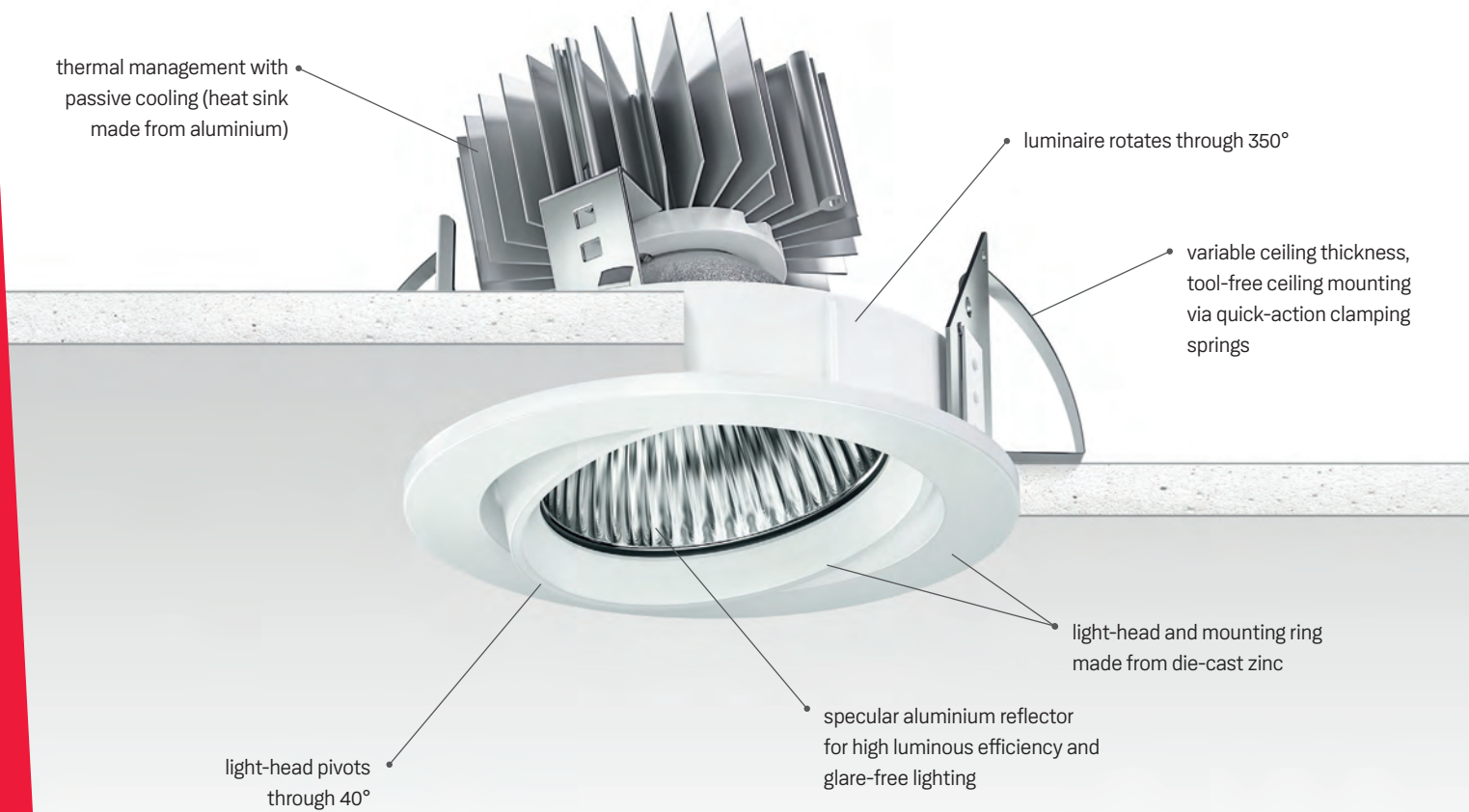

Standard options

|        |        |      |      |        |
|--------|--------|------|------|--------|
| 2700 K | BAKERY | MEAT | DALI | SILVER |
| 4000 K |        |      |      | WHITE  |

Special options

|        |              |     |      |           |         |         |            |                   |       |
|--------|--------------|-----|------|-----------|---------|---------|------------|-------------------|-------|
| 3500 K | CRI 90 SDCM3 | TWL | TWPI | MinusBlue | FASHION | PRODUCE | LUMEN PLUS | CONCRETE RECESSED | BLACK |
|--------|--------------|-----|------|-----------|---------|---------|------------|-------------------|-------|





Leonardo Royal Hotel, Ulm, GER · Planning: Neudahm Hotel Interior Design · Photo: Leuchtende Hotelfotografie

## Range selection



| Article name     | Beam angle | CCT [K] | System power [W] | Luminous flux [lm] | Installation depth [mm] | Cut-out [mm] | Ceiling thickness [mm] | Weight [kg] | EEC |
|------------------|------------|---------|------------------|--------------------|-------------------------|--------------|------------------------|-------------|-----|
| CSALP 60.1030.15 | 15°        | 3000    | 14               | 1430               | 100                     | Ø 125        | 1 - 25                 | 0.88        | A++ |
| CSALP 60.1030.25 | 25°        | 3000    | 14               | 1420               | 100                     | Ø 125        | 1 - 25                 | 0.88        | A++ |
| CSALP 60.1030.35 | 35°        | 3000    | 14               | 1410               | 100                     | Ø 125        | 1 - 25                 | 0.88        | A+  |
| CSALP 60.1030.50 | 50°        | 3000    | 14               | 1390               | 100                     | Ø 125        | 1 - 25                 | 0.88        | A+  |
| CSALP 60.2030.15 | 15°        | 3000    | 27               | 2740               | 110                     | Ø 125        | 1 - 25                 | 1.06        | A++ |
| CSALP 60.2030.25 | 25°        | 3000    | 27               | 2730               | 110                     | Ø 125        | 1 - 25                 | 1.06        | A++ |
| CSALP 60.2030.35 | 35°        | 3000    | 27               | 2710               | 110                     | Ø 125        | 1 - 25                 | 1.06        | A+  |
| CSALP 60.2030.50 | 50°        | 3000    | 27               | 2650               | 110                     | Ø 125        | 1 - 25                 | 1.06        | A+  |
| CSALP 60.3030.15 | 15°        | 3000    | 36               | 3640               | 130                     | Ø 125        | 1 - 25                 | 1.04        | A++ |
| CSALP 60.3030.25 | 25°        | 3000    | 36               | 3620               | 130                     | Ø 125        | 1 - 25                 | 1.04        | A+  |
| CSALP 60.3030.35 | 35°        | 3000    | 36               | 3600               | 130                     | Ø 125        | 1 - 25                 | 1.04        | A+  |
| CSALP 60.3030.50 | 50°        | 3000    | 36               | 3530               | 130                     | Ø 125        | 1 - 25                 | 1.04        | A+  |

## Accessories

| Article name     | Description  |
|------------------|--|
| ZDAR 125.145-205 | spacing ring for ceiling cut-outs from 145 to 205 mm |

Further product informations you will find under [www.its-light.eu/2330](http://www.its-light.eu/2330)

# CSA 72 Round

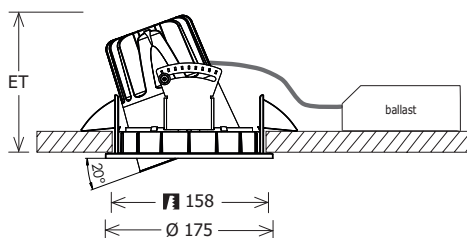
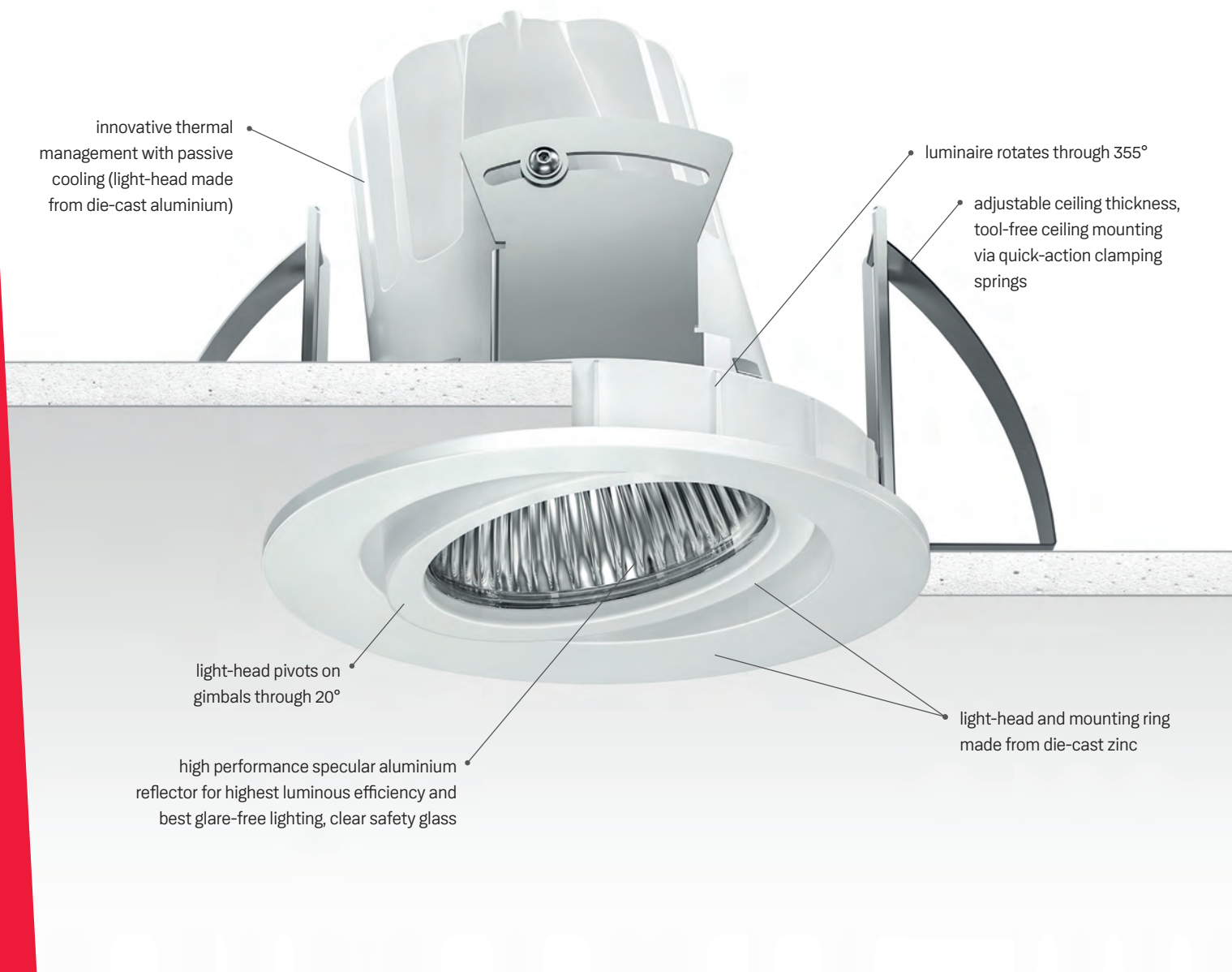

Standard options

|        |        |      |      |        |
|--------|--------|------|------|--------|
| 2700 K | BAKERY | MEAT | DALI | SILVER |
| 4000 K |        |      |      | WHITE  |

Special options

|        |              |     |      |           |         |         |                   |       |
|--------|--------------|-----|------|-----------|---------|---------|-------------------|-------|
| 3500 K | CRI 90 SDCM3 | TWL | TWPI | MinusBlue | FASHION | PRODUCE | CONCRETE RECESSED | BLACK |
|--------|--------------|-----|------|-----------|---------|---------|-------------------|-------|





Maranello Motors, Cologne, GER · Planning: Ferrari Deutschland · Photo: Enrique Salcedo Puerto



## Range selection

| Article name     | Beam angle | CCT [K] | System power [W] | Luminous flux [lm] | Installation depth [mm] | Cut-out [mm] | Ceiling thickness [mm] | Weight [kg] | EEC |
|------------------|------------|---------|------------------|--------------------|-------------------------|--------------|------------------------|-------------|-----|
| CSARL 72.2030.15 | 15°        | 3000    | 21               | 2420               | 145                     | Ø 158        | 1 - 25                 | 2.44        | A++ |
| CSARL 72.2030.25 | 25°        | 3000    | 21               | 2390               | 145                     | Ø 158        | 1 - 25                 | 2.44        | A++ |
| CSARL 72.2030.35 | 35°        | 3000    | 21               | 2360               | 145                     | Ø 158        | 1 - 25                 | 2.44        | A++ |
| CSARL 72.2030.50 | 50°        | 3000    | 21               | 2330               | 145                     | Ø 158        | 1 - 25                 | 2.44        | A++ |
| CSARL 72.3030.15 | 15°        | 3000    | 29               | 3230               | 145                     | Ø 158        | 1 - 25                 | 2.35        | A++ |
| CSARL 72.3030.25 | 25°        | 3000    | 29               | 3200               | 145                     | Ø 158        | 1 - 25                 | 2.35        | A++ |
| CSARL 72.3030.35 | 35°        | 3000    | 29               | 3170               | 145                     | Ø 158        | 1 - 25                 | 2.35        | A++ |
| CSARL 72.3030.50 | 50°        | 3000    | 29               | 3140               | 145                     | Ø 158        | 1 - 25                 | 2.35        | A++ |
| CSARL 72.4030.15 | 15°        | 3000    | 40               | 4360               | 145                     | Ø 158        | 1 - 25                 | 2.40        | A++ |
| CSARL 72.4030.25 | 25°        | 3000    | 40               | 4330               | 145                     | Ø 158        | 1 - 25                 | 2.40        | A++ |
| CSARL 72.4030.35 | 35°        | 3000    | 40               | 4300               | 145                     | Ø 158        | 1 - 25                 | 2.40        | A++ |
| CSARL 72.4030.50 | 50°        | 3000    | 40               | 4270               | 145                     | Ø 158        | 1 - 25                 | 2.40        | A++ |
| CSARL 72.5030.15 | 15°        | 3000    | 52               | 5490               | 145                     | Ø 158        | 1 - 25                 | 2.34        | A++ |
| CSARL 72.5030.25 | 25°        | 3000    | 52               | 5460               | 145                     | Ø 158        | 1 - 25                 | 2.34        | A++ |
| CSARL 72.5030.35 | 35°        | 3000    | 52               | 5430               | 145                     | Ø 158        | 1 - 25                 | 2.34        | A++ |
| CSARL 72.5030.50 | 50°        | 3000    | 52               | 5400               | 145                     | Ø 158        | 1 - 25                 | 2.34        | A++ |

## Accessories

| Article name     | Description  |
|------------------|--|
| ZDAR 158.200-265 | spacing ring for ceiling cut-outs from 200 to 265 mm |

Further product informations you will find under [www.its-light.eu/2340](http://www.its-light.eu/2340)



# Dallton XSmall

innovative thermal management with passive cooling (light-head made from die-cast)

light-head rotates through 355° and swivels through 30° by adjusting screw

easy ceiling mounting via leaf springs, variable ceiling thickness

individual optics by standard mounting frame round or square and in black, silver, white or trimless mounting frame flush with ceiling (all mounting frames made from die-cast)

reflectors made from plastic in chrome, chrome black, black matt, silver matt and white matt

**Note**  
 Also available as larger versions Dallton Small (page 68), Medium (page 70) and Large (page 72).  
 For simple planning use the Dallton Configurator on our website. Further informations on page 74.

Standard

Trimless

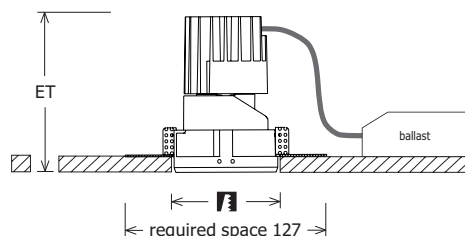
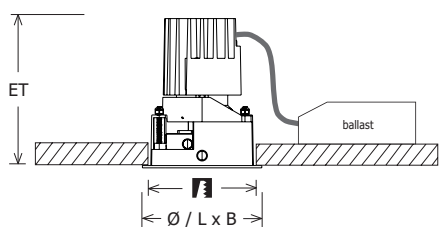

Standard options

|        |      |        |
|--------|------|--------|
| 2700 K | DALI | BLACK  |
| 4000 K |      | SILVER |
|        |      | WHITE  |

Special options

|                 |
|-----------------|
| CRI 90<br>SDCM3 |
|-----------------|



## Range selection



| Article name         | Feature   | Beam angle | CCT [K] | System power [W] | Luminous flux [lm] | Installation depth [mm] | EEC |
|----------------------|-----------|------------|---------|------------------|--------------------|-------------------------|-----|
| DAL-XS-LK 100.830.25 | lens      | 25°        | 3000    | 11               | 720                | 105                     | A   |
| DAL-XS-LK 100.830.40 | lens      | 40°        | 3000    | 11               | 770                | 105                     | A+  |
| DAL-XS-LK 100.830.55 | reflector | 55°        | 3000    | 11               | 630                | 105                     | A   |
| DAL-XS-LK 101.830.25 | lens      | 25°        | 3000    | 15               | 940                | 105                     | A   |
| DAL-XS-LK 101.830.40 | lens      | 40°        | 3000    | 15               | 1000               | 105                     | A   |
| DAL-XS-LK 101.830.55 | reflector | 55°        | 3000    | 15               | 820                | 105                     | A   |

## Accessories

| Article name     | Description  | L x B [mm] | Ø [mm] | Cut-out [mm] | Ceiling thickness [mm] | Weight [kg] |
|------------------|--|------------|--------|--------------|------------------------|-------------|
| DAL-XS-ESR 20    | mounting frame Standard round (black, silver, white)                 |            | 78     | 68           | 4 - 15                 | 0.04        |
| DAL-XS-ESQ 10    | mounting frame Standard square (black, silver, white)                | 77 x 77    |        | 68 x 68      | 1 - 21                 | 0.08        |
| DAL-XS-ETR 20    | mounting frame Trimless round (white)                                |            | 67     | 69           | 12.5 - 22.5            | 0.06        |
| DAL-XS-ETQ 10    | mounting frame Trimless square (white)                               | 67 x 67    |        | 69 x 69      | 12.5 - 22.5            | 0.08        |
| DAL-XS-RFR 20    | reflector flat round (chrome, chrome bk, bk matt, si matt, wh matt)  |            | 64     |              |                        | 0.01        |
| DAL-XS-RFQ 10    | reflector flat square (chrome, chrome bk, bk matt, si matt, wh matt) | 64 x 64    |        |              |                        | 0.02        |
| DAL-XS-ZBW 10.20 | honeycomb louvre   |            | 36     |              |                        | 0.01        |

Further product informations you will find under [www.lts-light.eu/2371](http://www.lts-light.eu/2371)

# Dallton Small

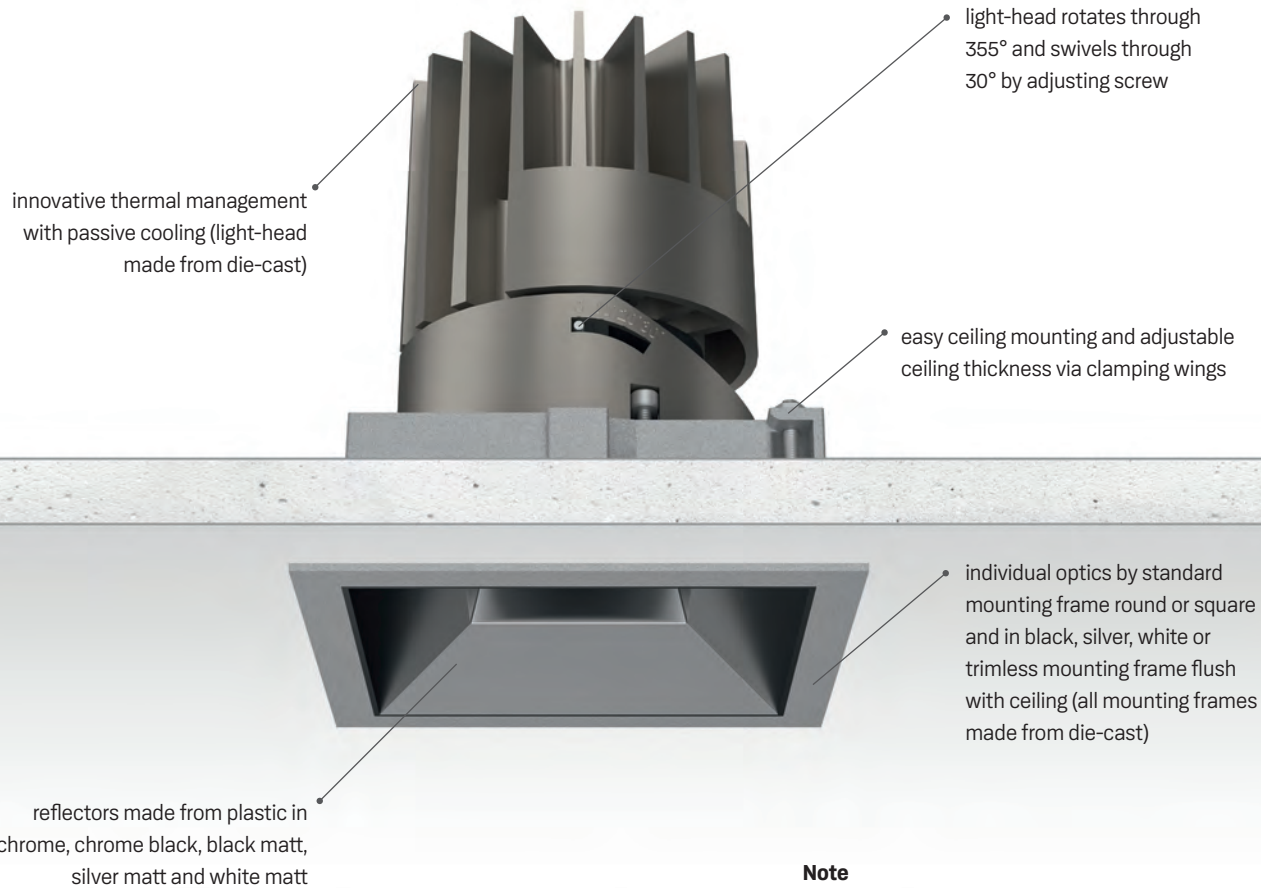

**Note**  
 Also available as smaller version **Dallton XSmall** (page 66) and larger versions **Dallton Medium** (page 70) and **Large** (page 72). For simple planning use the **Dallton Configurator** on our website. Further informations on page 74.

Standard

Trimless

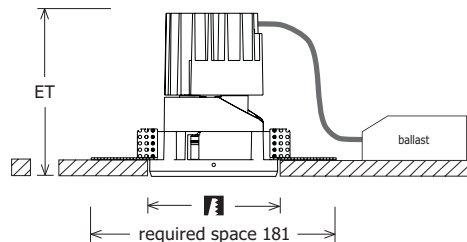
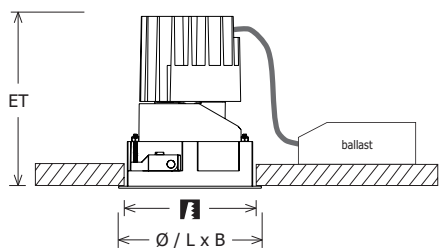

Standard options

|        |      |        |
|--------|------|--------|
| 2700 K | DALI | BLACK  |
| 4000 K |      | SILVER |
|        |      | WHITE  |

Special options

|                 |
|-----------------|
| CRI 90<br>SDCM3 |
|-----------------|





## Range selection



| Article name        | Beam angle | CCT [K] | System power [W] | Luminous flux [lm] | Installation depth [mm] | EEC |
|---------------------|------------|---------|------------------|--------------------|-------------------------|-----|
| DAL-S-LK 100.830.20 | 20°        | 3000    | 15               | 1150               | 135                     | A+  |
| DAL-S-LK 100.830.40 | 40°        | 3000    | 15               | 1070               | 135                     | A   |
| DAL-S-LK 100.830.50 | 50°        | 3000    | 15               | 1000               | 135                     | A   |
| DAL-S-LK 101.830.20 | 20°        | 3000    | 22               | 1580               | 135                     | A   |
| DAL-S-LK 101.830.40 | 40°        | 3000    | 22               | 1460               | 135                     | A   |
| DAL-S-LK 101.830.50 | 50°        | 3000    | 22               | 1360               | 135                     | A   |

## Accessories

| Article name    | Description  | L x B [mm] | Ø [mm] | Cut-out [mm] | Ceiling thickness [mm] | Weight [kg] |
|-----------------|--|------------|--------|--------------|------------------------|-------------|
| DAL-S-ESR 21    | mounting frame Standard round (black, silver, white)                 |            | 110    | 100          | 1 - 25                 | 0.12        |
| DAL-S-ESQ 11    | mounting frame Standard square (black, silver, white)                | 107 x 107  |        | 96 x 96      | 1 - 25                 | 0.12        |
| DAL-S-ETR 21    | mounting frame Trimless round (white)                                |            | 100    | 102          | 12.5 - 24.5            | 0.10        |
| DAL-S-ETQ 11    | mounting frame Trimless square (white)                               | 94 x 94    |        | 96 x 96      | 12.5 - 24.5            | 0.12        |
| DAL-S-RFR 21    | reflector flat round (chrome, chrome bk, bk matt, si matt, wh matt)  |            | 94     |              |                        | 0.02        |
| DAL-S-RTR 21    | reflector deep round (chrome, chrome bk, bk matt, si matt, wh matt)  |            | 94     |              |                        | 0.02        |
| DAL-S-RWR 21    | reflector wallwasher round (si matt)                                 |            | 94     |              |                        | 0.04        |
| DAL-S-RFQ 11    | reflector flat square (chrome, chrome bk, bk matt, si matt, wh matt) | 99 x 99    |        |              |                        | 0.03        |
| DAL-S-RTQ 11    | reflector deep square (chrome, chrome bk, bk matt, si matt, wh matt) | 99 x 99    |        |              |                        | 0.04        |
| DAL-S-RWQ 11    | reflector wallwasher square (si matt)                                | 99 x 99    |        |              |                        | 0.05        |
| DAL-S-ZBW 11.21 | honeycomb louvre   |            | 43     |              |                        | 0.01        |

Further product informations you will find under [www.lts-light.eu/2370](http://www.lts-light.eu/2370)

# Dallton Medium

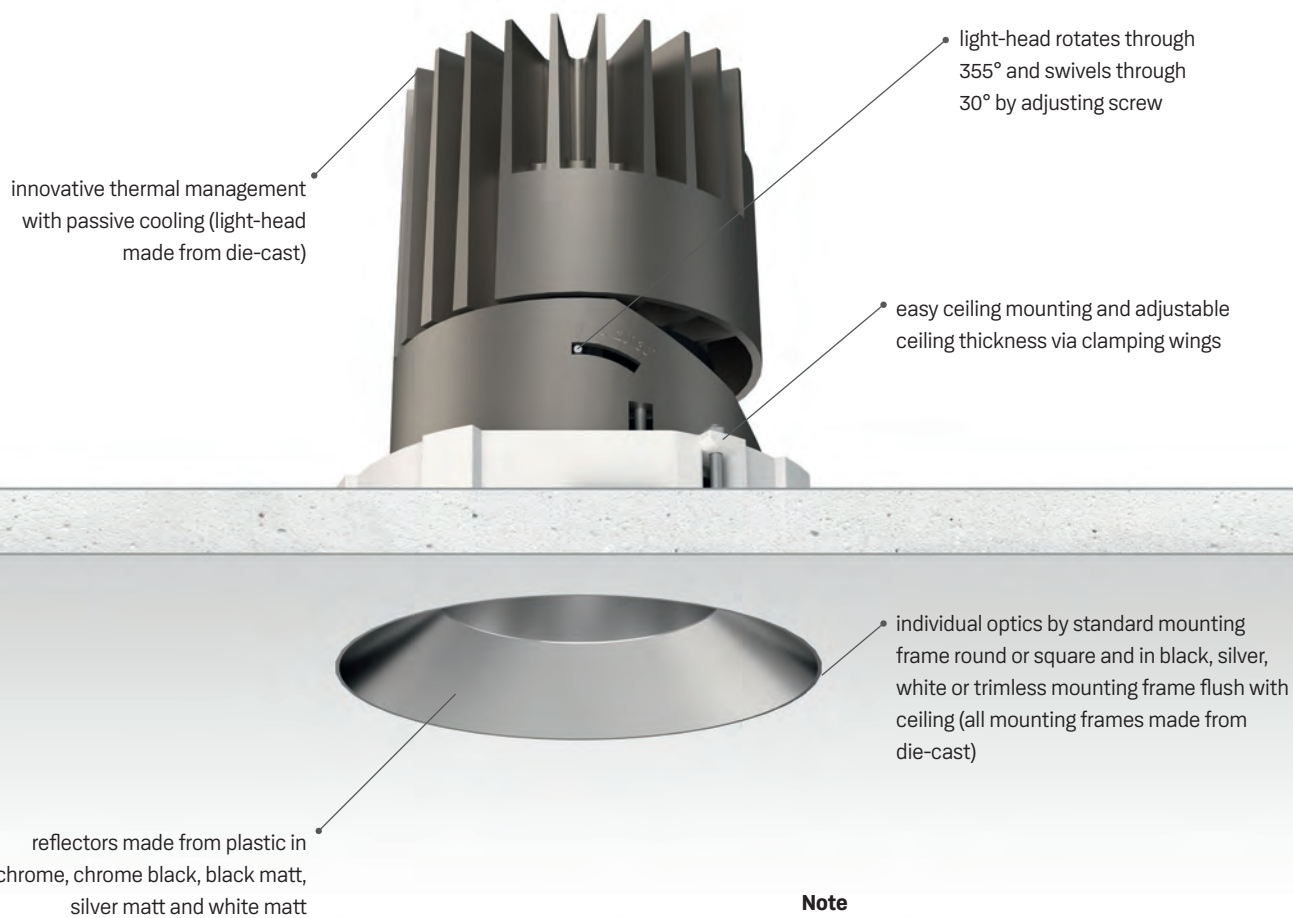

**Note**  
 Also available as smaller versions Dallton XSmall (page 66), Small (page 68) and larger version Dallton Large (page 72). For simple planning use the Dallton Configurator on our website. Further informations on page 74.

Standard

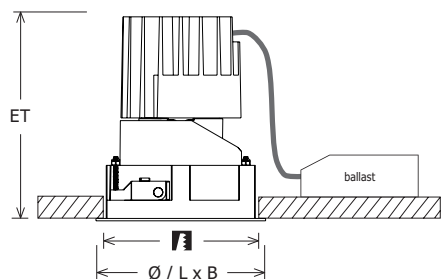

Trimless

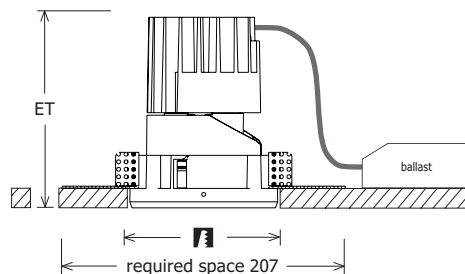

Standard options

|        |      |                          |
|--------|------|--------------------------|
| 4000 K | DALI | BLACK<br>SILVER<br>WHITE |
|--------|------|--------------------------|

Special options

|        |                 |
|--------|-----------------|
| 2700 K | CRI 90<br>SDCM3 |
|--------|-----------------|



## Range selection



| Article name        | Beam angle | CCT [K] | System power [W] | Luminous flux [lm] | Installation depth [mm] | EEC |
|---------------------|------------|---------|------------------|--------------------|-------------------------|-----|
| DAL-M-LK 101.830.20 | 20°        | 3000    | 21               | 1610               | 170                     | A   |
| DAL-M-LK 101.830.40 | 40°        | 3000    | 21               | 1620               | 170                     | A   |
| DAL-M-LK 101.830.50 | 50°        | 3000    | 21               | 1770               | 170                     | A+  |
| DAL-M-LK 102.830.20 | 20°        | 3000    | 28               | 2150               | 170                     | A   |
| DAL-M-LK 102.830.40 | 40°        | 3000    | 28               | 2170               | 170                     | A   |
| DAL-M-LK 102.830.50 | 50°        | 3000    | 28               | 2360               | 170                     | A+  |

## Accessories

| Article name    | Description  | L x B [mm] | Ø [mm] | Cut-out [mm] | Ceiling thickness [mm] | Weight [kg] |
|-----------------|--|------------|--------|--------------|------------------------|-------------|
| DAL-M-ESR 22    | mounting frame Standard round (black, silver, white)                 |            | 137    | 125          | 1 - 33                 | 0.16        |
| DAL-M-ESQ 12    | mounting frame Standard square (black, silver, white)                | 132 x 132  |        | 122 x 122    | 1 - 30                 | 0.22        |
| DAL-M-ETR 22    | mounting frame Trimless round (white)                                |            | 125    | 127          | 12.5 - 24.5            | 0.16        |
| DAL-M-ETQ 12    | mounting frame Trimless square (white)                               | 120 x 120  |        | 122 x 122    | 12.5 - 24.5            | 0.20        |
| DAL-M-RFR 22    | reflector flat round (chrome, chrome bk, bk matt, si matt, wh matt)  |            | 119    |              |                        | 0.04        |
| DAL-M-RTR 22    | reflector deep round (chrome, chrome bk, bk matt, si matt, wh matt)  |            | 119    |              |                        | 0.06        |
| DAL-M-RWR 22    | reflector wallwasher round (si matt)                                 |            | 119    |              |                        | 0.06        |
| DAL-M-RFQ 12    | reflector flat square (chrome, chrome bk, bk matt, si matt, wh matt) | 114 x 114  |        |              |                        | 0.06        |
| DAL-M-RTQ 12    | reflector deep square (chrome, chrome bk, bk matt, si matt, wh matt) | 114 x 114  |        |              |                        | 0.07        |
| DAL-M-RWQ 12    | reflector wallwasher square (si matt)                                | 114 x 114  |        |              |                        | 0.10        |
| DAL-M-ZBW 12.22 | honeycomb louvre   |            | 60     |              |                        | 0.02        |

Further product informations you will find under [www.lts-light.eu/2369](http://www.lts-light.eu/2369)



# Dallton Large

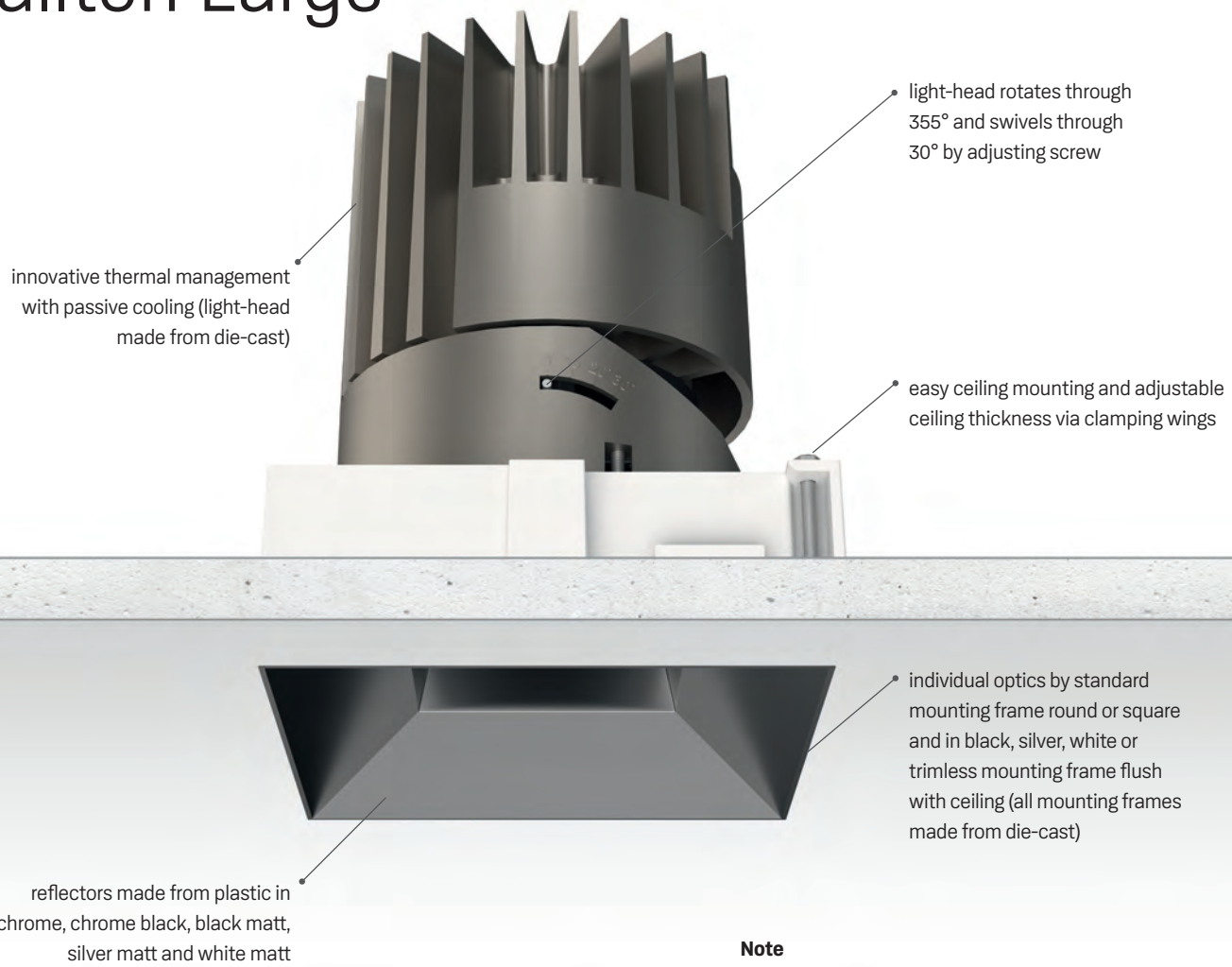

**Note**  
 Also available as smaller versions Dallton XSmall (page 66), Small (page 68) and Medium (page 70).  
 For simple planning use the Dallton Configurator on our website. Further informations on page 74.

Standard

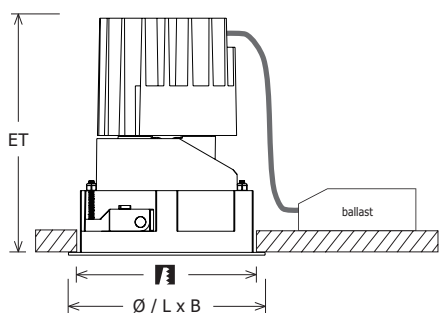

Trimless

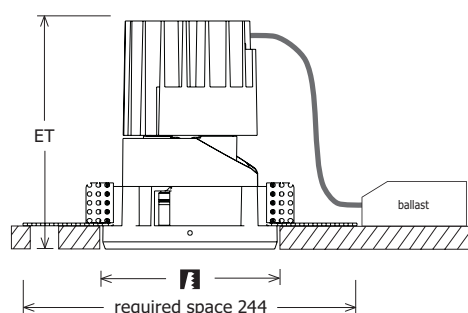

Standard options

|        |      |                          |
|--------|------|--------------------------|
| 4000 K | DALI | BLACK<br>SILVER<br>WHITE |
|--------|------|--------------------------|

Special options

|        |                 |
|--------|-----------------|
| 2700 K | CRI 90<br>SDCM3 |
|--------|-----------------|



## Range selection



| Article name        | Beam angle | CCT [K] | System power [W] | Luminous flux [lm] | Installation depth [mm] | EEC |
|---------------------|------------|---------|------------------|--------------------|-------------------------|-----|
| DAL-L-LK 101.830.20 | 20°        | 3000    | 28               | 2350               | 200                     | A   |
| DAL-L-LK 101.830.35 | 35°        | 3000    | 28               | 2210               | 200                     | A   |
| DAL-L-LK 101.830.50 | 50°        | 3000    | 28               | 2230               | 200                     | A   |
| DAL-L-LK 102.830.20 | 20°        | 3000    | 43               | 3470               | 200                     | A+  |
| DAL-L-LK 102.830.35 | 35°        | 3000    | 43               | 3280               | 200                     | A   |
| DAL-L-LK 102.830.50 | 50°        | 3000    | 43               | 3300               | 200                     | A   |

## Accessories

| Article name    | Description  | L x B [mm] | Ø [mm] | Cut-out [mm] | Ceiling thickness [mm] | Weight [kg] |
|-----------------|--|------------|--------|--------------|------------------------|-------------|
| DAL-L-ESR 23    | mounting frame Standard round (black, silver, white)                 |            | 162    | 150          | 1 - 36                 | 0.24        |
| DAL-L-ESQ 13    | mounting frame Standard square (black, silver, white)                | 159 x 159  |        | 147 x 147    | 1 - 36                 | 0.32        |
| DAL-L-ETR 23    | mounting frame Trimless round (white)                                |            | 150    | 152          | 12.5 - 24.5            | 0.24        |
| DAL-L-ETQ 13    | mounting frame Trimless square (white)                               | 145 x 145  |        | 147 x 147    | 12.5 - 24.5            | 0.32        |
| DAL-L-RFR 23    | reflector flat round (chrome, chrome bk, bk matt, si matt, wh matt)  |            | 143    |              |                        | 0.06        |
| DAL-L-RTR 23    | reflector deep round (chrome, chrome bk, bk matt, si matt, wh matt)  |            | 143    |              |                        | 0.08        |
| DAL-L-RWR 23    | reflector wallwasher round (si matt)                                 |            | 143    |              |                        | 0.10        |
| DAL-L-RFQ 13    | reflector flat square (chrome, chrome bk, bk matt, si matt, wh matt) | 139 x 139  |        |              |                        | 0.08        |
| DAL-L-RTQ 13    | reflector deep square (chrome, chrome bk, bk matt, si matt, wh matt) | 139 x 139  |        |              |                        | 0.10        |
| DAL-L-RWQ 13    | reflector wallwasher square (si matt)                                | 139 x 139  |        |              |                        | 0.14        |
| DAL-L-ZBW 13.23 | honeycomb louvre   |            | 72     |              |                        | 0.02        |

Further product informations you will find under [www.lts-light.eu/2368](http://www.lts-light.eu/2368)

# SPOTLIGHTS WITH A SYSTEM

THE DALLTON-SERIES

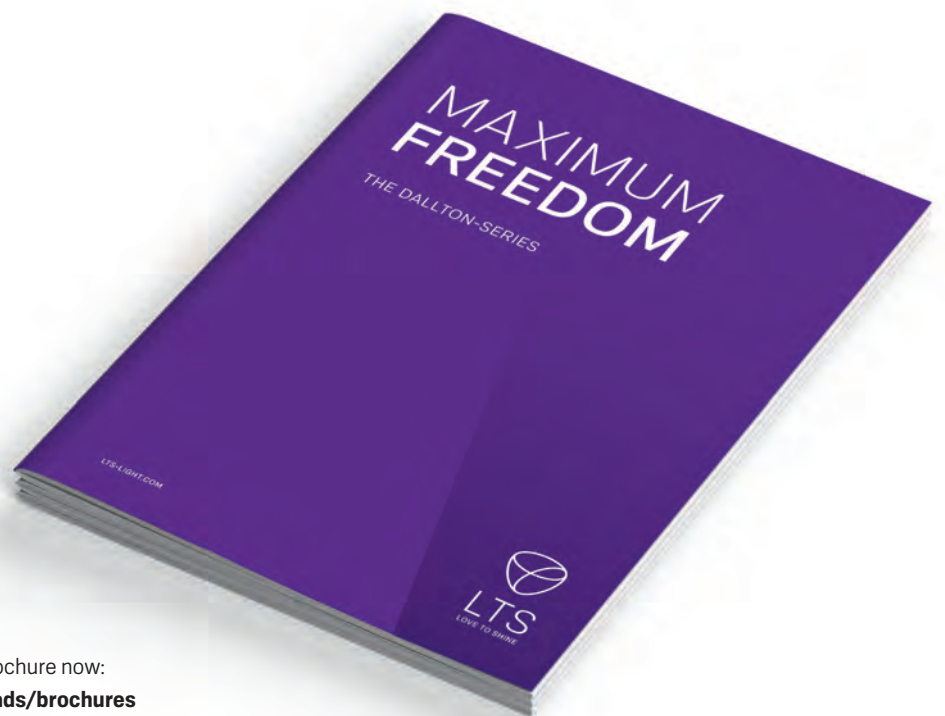

Download the new Dallton brochure now:  
[www.lts-light.com/downloads/brochures](http://www.lts-light.com/downloads/brochures)



# QUICK AND EASY

## THE DALLTON CONFIGURATOR

The recessed spotlights of the new Dallton series are available in four sizes. There are a great number of ways in which these can be individually designed. Installation frames and front reflectors in different shapes, depths and colours provide optimum creative freedom. The range is complemented with various colour temperatures and DALI.

Well over 100 solutions can be created by combining the many options. Too many? It's easy with our configurator. Our configurator delivers both the perfect result, fully meeting requirements, and the appropriate specification documents, data sheets and other data for lighting design.



System 01

Mounting type 02

Installation frame 03

Reflector 04

DALI 05

Colour temperature 06

Beam angle 07

System power & luminous flux 08



Design your individual Dallton spotlights now:  
[app.lts-light.com/lichtsystem-en](http://app.lts-light.com/lichtsystem-en)

# Scene 1 System

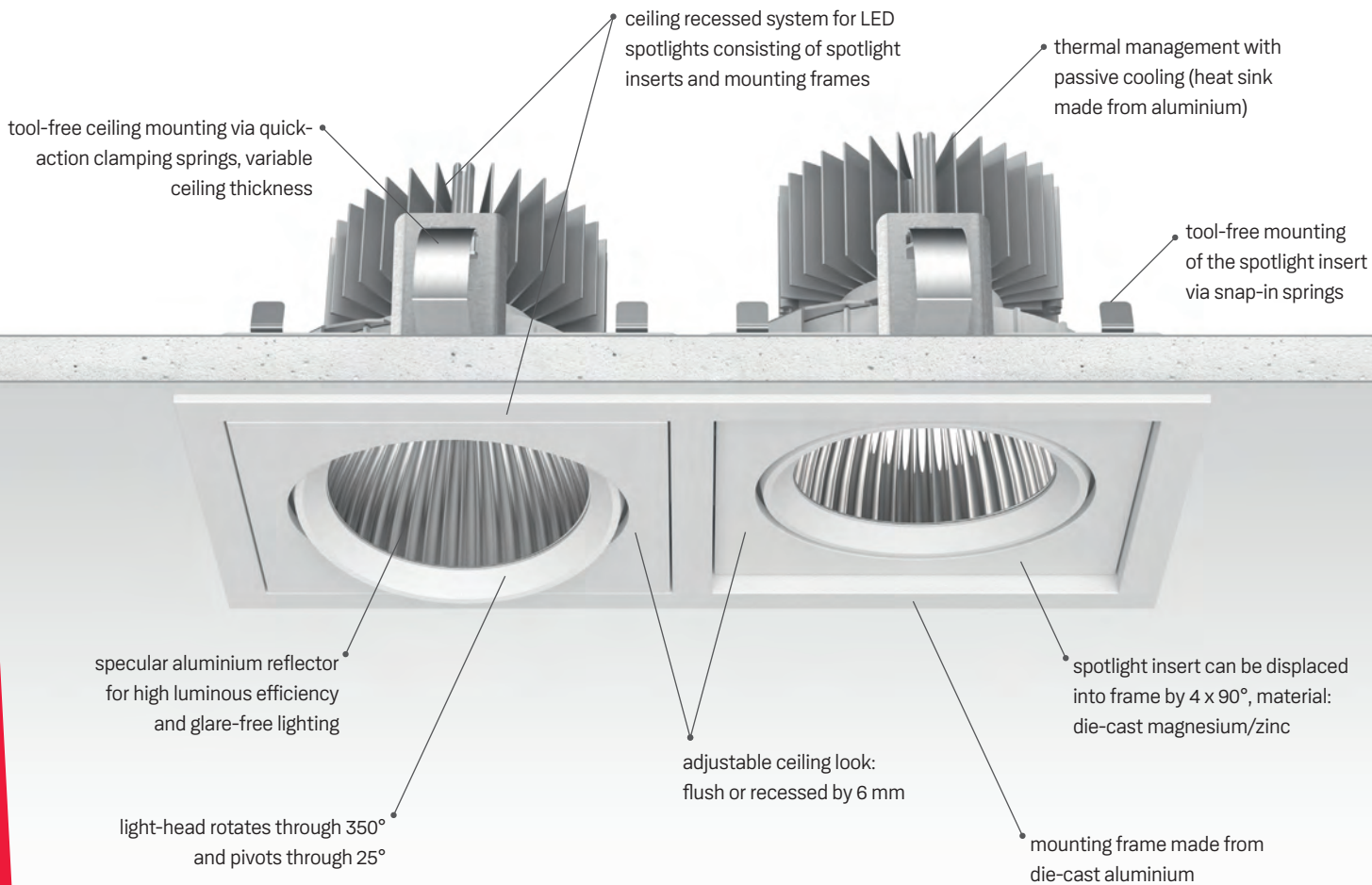

**Note**  
 For simple planning use the „light trunking system configurator“ on our website.

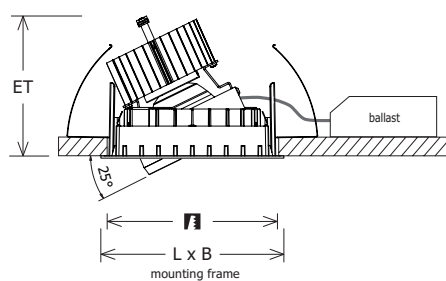

**Standard options**

|        |                        |      |            |           |
|--------|------------------------|------|------------|-----------|
| 2700 K | BAKERY                 | MEAT | DALI       | SILVER    |
| 4000 K |                        |      |            | WHITE     |
| 3500 K | <b>CRI 90</b><br>SDCM3 | TWL  | TWPI       | MinusBlue |
|        |                        |      | FASHION    | PRODUCE   |
|        |                        |      | LUMEN PLUS | BLACK     |

**Special options**



Wolford, Bregenz, AUT · Planning: Wolford · Photo: Jean-Marc Delettre – Photography

## Range selection



| Article name      | Beam angle | CCT [K] | System power [W] | Luminous flux [lm] | Installation depth [mm] | Weight [kg] | EEC |
|-------------------|------------|---------|------------------|--------------------|-------------------------|-------------|-----|
| SCEKLP 10.1030.15 | 15°        | 3000    | 14               | 1430               | 118                     | 0.80        | A++ |
| SCEKLP 10.1030.25 | 25°        | 3000    | 14               | 1420               | 118                     | 0.80        | A++ |
| SCEKLP 10.1030.35 | 35°        | 3000    | 14               | 1410               | 118                     | 0.80        | A+  |
| SCEKLP 10.1030.50 | 50°        | 3000    | 14               | 1390               | 118                     | 0.80        | A+  |
| SCEKLP 10.2030.15 | 15°        | 3000    | 27               | 2740               | 118                     | 0.98        | A++ |
| SCEKLP 10.2030.25 | 25°        | 3000    | 27               | 2730               | 118                     | 0.98        | A++ |
| SCEKLP 10.2030.35 | 35°        | 3000    | 27               | 2710               | 118                     | 0.98        | A+  |
| SCEKLP 10.2030.50 | 50°        | 3000    | 27               | 2650               | 118                     | 0.98        | A+  |
| SCEKLP 10.3030.15 | 15°        | 3000    | 36               | 3640               | 135                     | 0.96        | A++ |
| SCEKLP 10.3030.25 | 25°        | 3000    | 36               | 3620               | 135                     | 0.96        | A+  |
| SCEKLP 10.3030.35 | 35°        | 3000    | 36               | 3600               | 135                     | 0.96        | A+  |
| SCEKLP 10.3030.50 | 50°        | 3000    | 36               | 3530               | 135                     | 0.96        | A+  |

## Accessories

| Article name | Description           | L x B [mm] | Cut-out [mm] | Ceiling thickness [mm] | Weight [kg] |
|--------------|-----------------------|------------|--------------|------------------------|-------------|
| SCER 1.100   | mounting frame 1-lamp | 151 x 151  | 140 x 145    | 1 - 25                 | 0.2         |
| SCER 1.200   | mounting frame 2-lamp | 289 x 151  | 278 x 145    | 1 - 25                 | 0.4         |
| SCER 1.300   | mounting frame 3-lamp | 427 x 151  | 416 x 145    | 1 - 25                 | 0.6         |

Further product informations you will find under [www.lts-light.eu/2801](http://www.lts-light.eu/2801)



# Scene 33 System

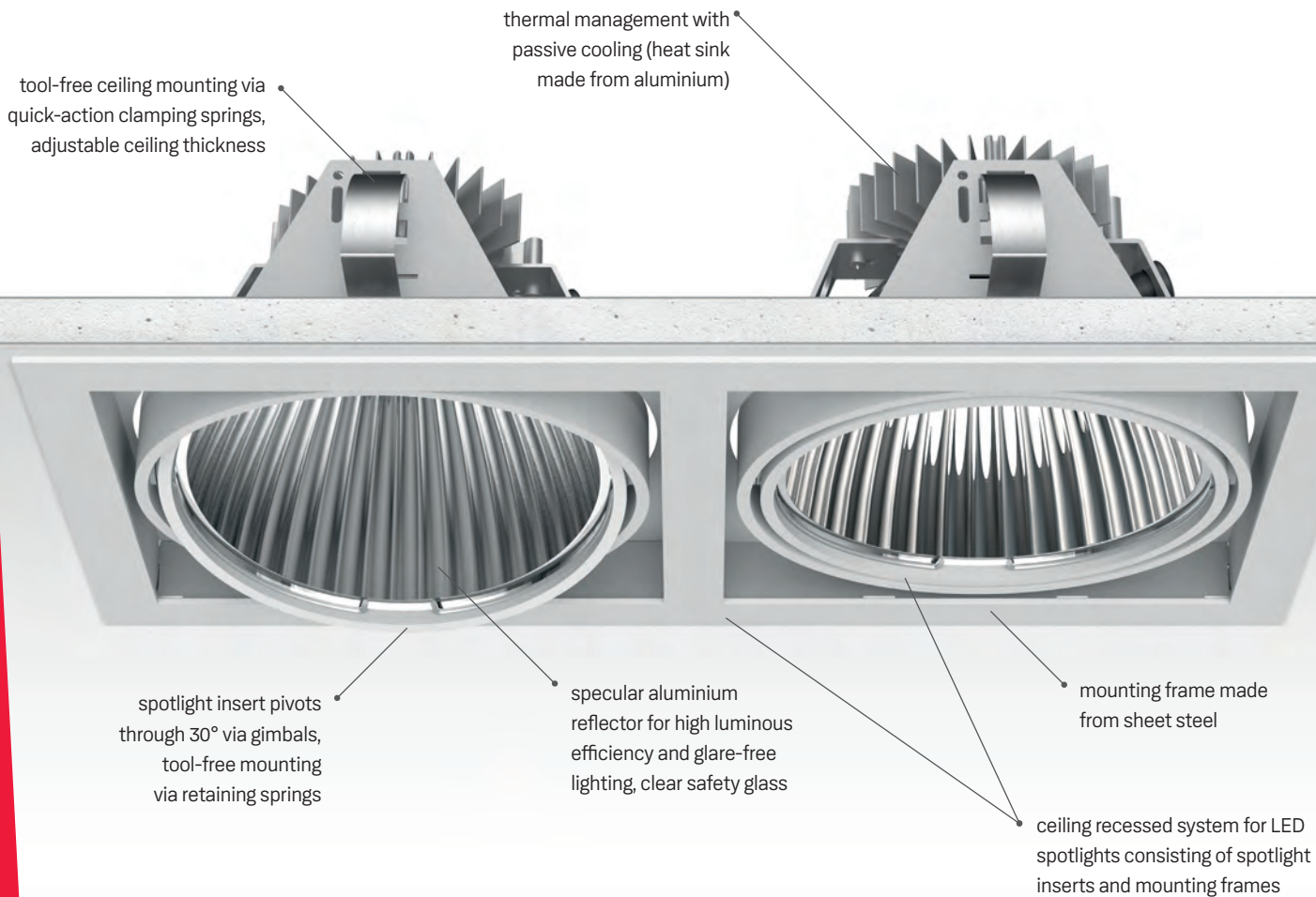

**Note**  
 For simple planning use the „light trunking system configurator“ on our website.

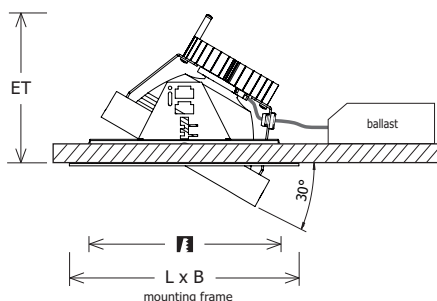

**Standard options**

|        |        |      |      |                 |
|--------|--------|------|------|-----------------|
| 4000 K | BAKERY | MEAT | DALI | SILVER<br>WHITE |
|--------|--------|------|------|-----------------|

**Special options**

|                  |                 |     |      |           |     |         |         |            |       |
|------------------|-----------------|-----|------|-----------|-----|---------|---------|------------|-------|
| 2700 K<br>3500 K | CRI 90<br>SDCM3 | TWL | TWPI | MinusBlue | HBT | FASHION | PRODUCE | LUMEN PLUS | BLACK |
|------------------|-----------------|-----|------|-----------|-----|---------|---------|------------|-------|



Jack Barclay Bentley, London, GB · Photo: H. R. Owen

## Range selection



| Article name       | Beam angle | CCT [K] | System power [W] | Luminous flux [lm] | Installation depth [mm] | Cooling         | Weight [kg] | EEC |
|--------------------|------------|---------|------------------|--------------------|-------------------------|-----------------|-------------|-----|
| SCEKLP 33.2030.15  | 15°        | 3000    | 27               | 2620               | 138                     | cooling profile | 1.10        | A+  |
| SCEKLP 33.2030.25  | 25°        | 3000    | 27               | 2750               | 138                     | cooling profile | 1.10        | A++ |
| SCEKLP 33.2030.35  | 35°        | 3000    | 27               | 2640               | 138                     | cooling profile | 1.10        | A+  |
| SCEKLP 33.2030.55  | 55°        | 3000    | 27               | 2750               | 138                     | cooling profile | 1.10        | A++ |
| SCEKLP 33.3030.15  | 15°        | 3000    | 36               | 3310               | 155                     | cooling profile | 1.08        | A+  |
| SCEKLP 33.3030.25  | 25°        | 3000    | 36               | 3470               | 155                     | cooling profile | 1.08        | A+  |
| SCEKLP 33.3030.35  | 35°        | 3000    | 36               | 3330               | 155                     | cooling profile | 1.08        | A+  |
| SCEKLP 33.3030.55  | 55°        | 3000    | 36               | 3470               | 155                     | cooling profile | 1.08        | A+  |
| SCEKLP 33.5030.15  | 15°        | 3000    | 52               | 5310               | 185                     | cooling profile | 1.22        | A++ |
| SCEKLP 33.5030.25  | 25°        | 3000    | 52               | 5580               | 185                     | cooling profile | 1.22        | A++ |
| SCEKLP 33.5030.35  | 35°        | 3000    | 52               | 5350               | 185                     | cooling profile | 1.22        | A++ |
| SCEKLP 33.5030.55  | 55°        | 3000    | 52               | 5580               | 185                     | cooling profile | 1.22        | A++ |
| SCEKLP 33.10030.15 | 15°        | 3000    | 97               | 10230              | 500                     | heatpipe        | 1.64        | A++ |
| SCEKLP 33.10030.25 | 25°        | 3000    | 97               | 10720              | 500                     | heatpipe        | 1.64        | A++ |
| SCEKLP 33.10030.35 | 35°        | 3000    | 97               | 10300              | 500                     | heatpipe        | 1.64        | A++ |
| SCEKLP 33.10030.55 | 55°        | 3000    | 97               | 10720              | 500                     | heatpipe        | 1.64        | A++ |

## Accessories

| Article name | Description                    | L x B [mm] | Ø [mm] | Cut-out [mm] | Ceiling thickness [mm] | Weight [kg] |
|--------------|--------------------------------|------------|--------|--------------|------------------------|-------------|
| SCER 33.100  | mounting frame 1-lamp (square) | 200 x 200  |        | 182 x 182    | 5 - 30                 | 0.4         |
| SCER 33.111  | mounting frame 1-lamp (round)  |            | 230    | Ø 190        | 5 - 30                 | 0.6         |
| SCER 33.200  | mounting frame 2-lamp (square) | 381 x 200  |        | 360 x 182    | 5 - 30                 | 0.7         |
| SCER 33.300  | mounting frame 3-lamp (square) | 562 x 200  |        | 540 x 182    | 5 - 30                 | 1.0         |
| SCER 33.400  | mounting frame 4-lamp (square) | 365 x 355  |        | 360 x 360    | 5 - 30                 | 1.3         |

Further product informations you will find under [www.lts-light.eu/2807](http://www.lts-light.eu/2807)

# Scene 4

thermal management with passive cooling (heat sink made from aluminium)

tool-free ceiling mounting via quick-action clamping springs, variable ceiling thickness

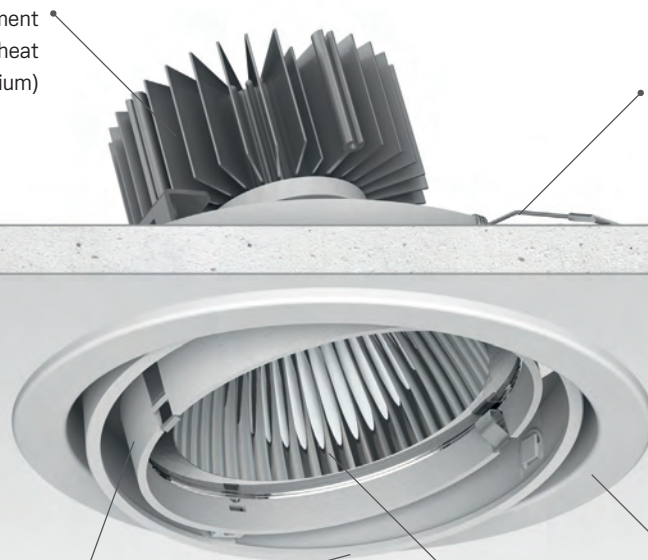

gimbals made from die-cast zinc, light-head pivots through 27° via gimbals

mounting ring made from sheet steel

specular aluminium reflector for high luminous efficiency and glare-free lighting, clear safety glass

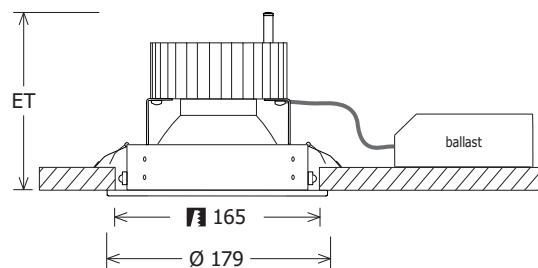

Standard options

|        |        |      |      |        |
|--------|--------|------|------|--------|
| 2700 K | BAKERY | MEAT | DALI | SILVER |
| 4000 K |        |      |      | WHITE  |

Special options

|        |              |     |      |           |         |         |             |                   |       |
|--------|--------------|-----|------|-----------|---------|---------|-------------|-------------------|-------|
| 3500 K | CRI 90 SDCM3 | TWL | TWPI | MinusBlue | FASHION | PRODUCE | LEAF SPRING | CONCRETE RECESSED | BLACK |
|--------|--------------|-----|------|-----------|---------|---------|-------------|-------------------|-------|





GreenGlam Naturkosmetik, Augsburg, GER · Photo: Jean-Marc Delettre – Photography

## Range selection



| Article name      | Beam angle | CCT [K] | System power [W] | Luminous flux [lm] | Installation depth [mm] | Cut-out [mm] | Ceiling thickness [mm] | Weight [kg] | EEC |
|-------------------|------------|---------|------------------|--------------------|-------------------------|--------------|------------------------|-------------|-----|
| SCELP 401.1030.15 | 15°        | 3000    | 14               | 1410               | 123                     | Ø 165        | 10 - 30                | 0.96        | A+  |
| SCELP 401.1030.25 | 25°        | 3000    | 14               | 1400               | 123                     | Ø 165        | 10 - 30                | 0.96        | A+  |
| SCELP 401.1030.35 | 35°        | 3000    | 14               | 1390               | 123                     | Ø 165        | 10 - 30                | 0.96        | A+  |
| SCELP 401.1030.45 | 45°        | 3000    | 14               | 1380               | 123                     | Ø 165        | 10 - 30                | 0.96        | A+  |
| SCELP 401.2030.15 | 15°        | 3000    | 27               | 2710               | 123                     | Ø 165        | 10 - 30                | 1.14        | A+  |
| SCELP 401.2030.25 | 25°        | 3000    | 27               | 2700               | 123                     | Ø 165        | 10 - 30                | 1.14        | A+  |
| SCELP 401.2030.35 | 35°        | 3000    | 27               | 2680               | 123                     | Ø 165        | 10 - 30                | 1.14        | A+  |
| SCELP 401.2030.45 | 45°        | 3000    | 27               | 2650               | 123                     | Ø 165        | 10 - 30                | 1.14        | A+  |
| SCELP 401.3030.15 | 15°        | 3000    | 36               | 3600               | 140                     | Ø 165        | 10 - 30                | 1.12        | A+  |
| SCELP 401.3030.25 | 25°        | 3000    | 36               | 3580               | 140                     | Ø 165        | 10 - 30                | 1.12        | A+  |
| SCELP 401.3030.35 | 35°        | 3000    | 36               | 3560               | 140                     | Ø 165        | 10 - 30                | 1.12        | A+  |
| SCELP 401.3030.45 | 45°        | 3000    | 36               | 3530               | 140                     | Ø 165        | 10 - 30                | 1.12        | A+  |

## Accessories

| Article name | Description      |
|--------------|------------------|
| ZBW 20       | honeycomb louvre |

Further product informations you will find under [www.lts-light.eu/2332](http://www.lts-light.eu/2332)

# Vale-Tu Round Small/Medium

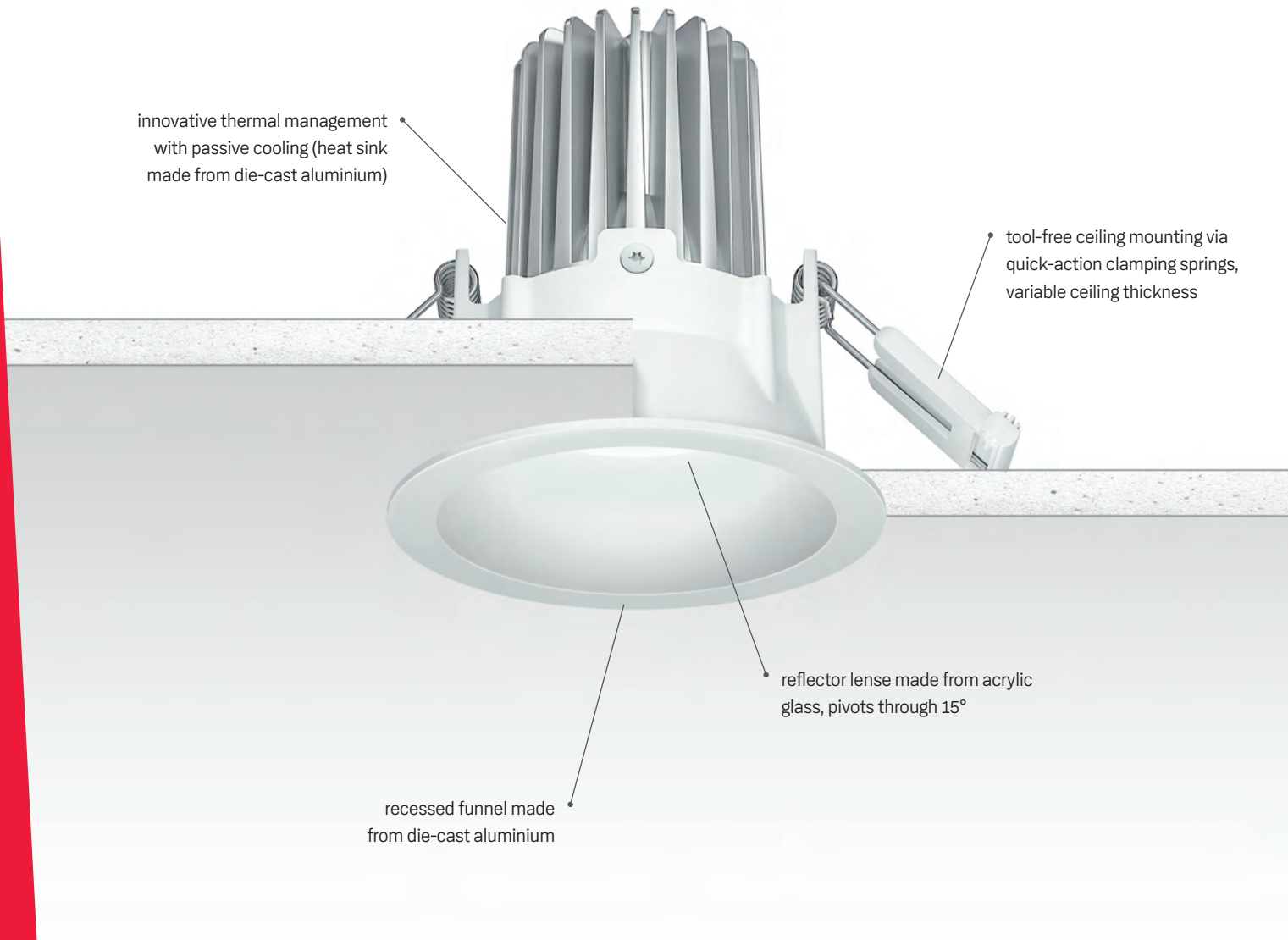

innovative thermal management with passive cooling (heat sink made from die-cast aluminium)

tool-free ceiling mounting via quick-action clamping springs, variable ceiling thickness

reflector lens made from acrylic glass, pivots through 15°

recessed funnel made from die-cast aluminium

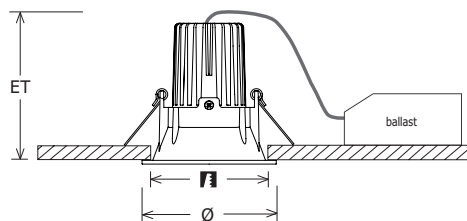

Standard options

|        |      |     |       |
|--------|------|-----|-------|
| 2700 K | DALI | 60° | BLACK |
| 4000 K |      |     |       |

Special options

|                   |
|-------------------|
| CONCRETE RECESSED |
|-------------------|



Maranello Motors, Cologne, GER · Planning: Ferrari Deutschland · Photo: Enrique Salcedo Puerto

## Range selection



| Article name    | Ø [mm] | Colour | Beam angle | CCT [K] | System power [W] | Luminous flux [lm] | Installation depth [mm] | Cut-out [mm] | Ceiling thickness [mm] | Weight [kg] | EEC |
|-----------------|--------|--------|------------|---------|------------------|--------------------|-------------------------|--------------|------------------------|-------------|-----|
| VTRS 10.0530.25 | 80     | silver | 25°        | 3000    | 12               | 1010               | 112                     | Ø 70         | 10 - 15                | 0.48        | A+  |
| VTRS 10.0530.35 | 80     | silver | 35°        | 3000    | 12               | 1050               | 112                     | Ø 70         | 10 - 15                | 0.48        | A+  |
| VTRS 13.0530.25 | 80     | white  | 25°        | 3000    | 12               | 1010               | 112                     | Ø 70         | 10 - 15                | 0.48        | A+  |
| VTRS 13.0530.35 | 80     | white  | 35°        | 3000    | 12               | 1050               | 112                     | Ø 70         | 10 - 15                | 0.48        | A+  |
| VTRM 10.0530.25 | 90     | silver | 25°        | 3000    | 12               | 1080               | 117                     | Ø 78         | 10 - 15                | 0.49        | A+  |
| VTRM 10.0530.35 | 90     | silver | 35°        | 3000    | 12               | 1120               | 117                     | Ø 78         | 10 - 15                | 0.49        | A+  |
| VTRM 13.0530.25 | 90     | white  | 25°        | 3000    | 12               | 1080               | 117                     | Ø 78         | 10 - 15                | 0.49        | A+  |
| VTRM 13.0530.35 | 90     | white  | 35°        | 3000    | 12               | 1120               | 117                     | Ø 78         | 10 - 15                | 0.49        | A+  |

Further product informations you will find under [www.lts-light.eu/2346](http://www.lts-light.eu/2346) or **2347**



# Vale-Tu Round XSmall

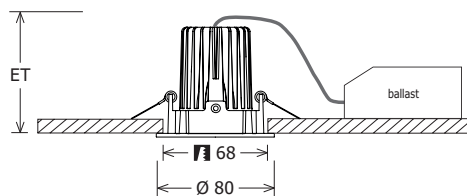
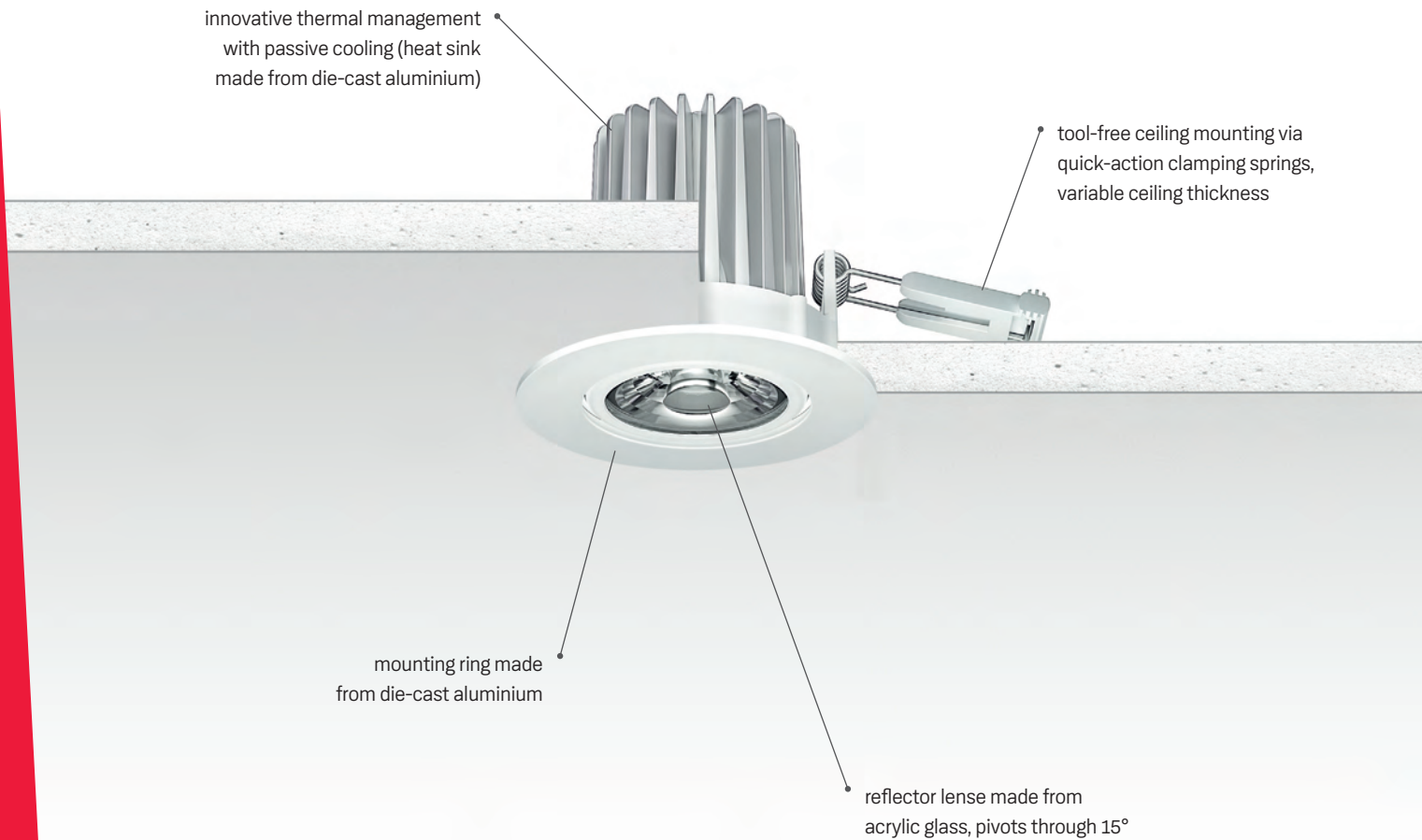

Standard options

|        |      |     |       |
|--------|------|-----|-------|
| 2700 K | DALI | 60° | BLACK |
| 4000 K |      |     |       |

Special options

|                   |
|-------------------|
| CONCRETE RECESSED |
|-------------------|



Leonardo Royal Hotel, Ulm, GER · Planning: Neudahm Hotel Interior Design · Photo: Leuchtende Hotelfotografie

## Range selection



| Article name     | Colour | Beam angle | CCT [K] | System power [W] | Luminous flux [lm] | Installation depth [mm] | Cut-out [mm] | Ceiling thickness [mm] | EEC |
|------------------|--------|------------|---------|------------------|--------------------|-------------------------|--------------|------------------------|-----|
| VTRXS 10.0530.25 | silver | 25°        | 3000    | 12               | 1120               | 87                      | Ø 68         | 10 - 15                | A+  |
| VTRXS 10.0530.35 | silver | 35°        | 3000    | 12               | 1160               | 87                      | Ø 68         | 10 - 15                | A+  |
| VTRXS 13.0530.25 | white  | 25°        | 3000    | 12               | 1120               | 87                      | Ø 68         | 10 - 15                | A+  |
| VTRXS 13.0530.35 | white  | 35°        | 3000    | 12               | 1160               | 87                      | Ø 68         | 10 - 15                | A+  |

Further product informations you will find under [www.lts-light.eu/2348](http://www.lts-light.eu/2348)

# Vale-Tu Square Small/Medium

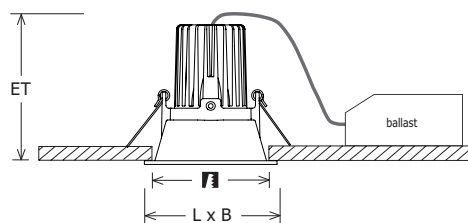
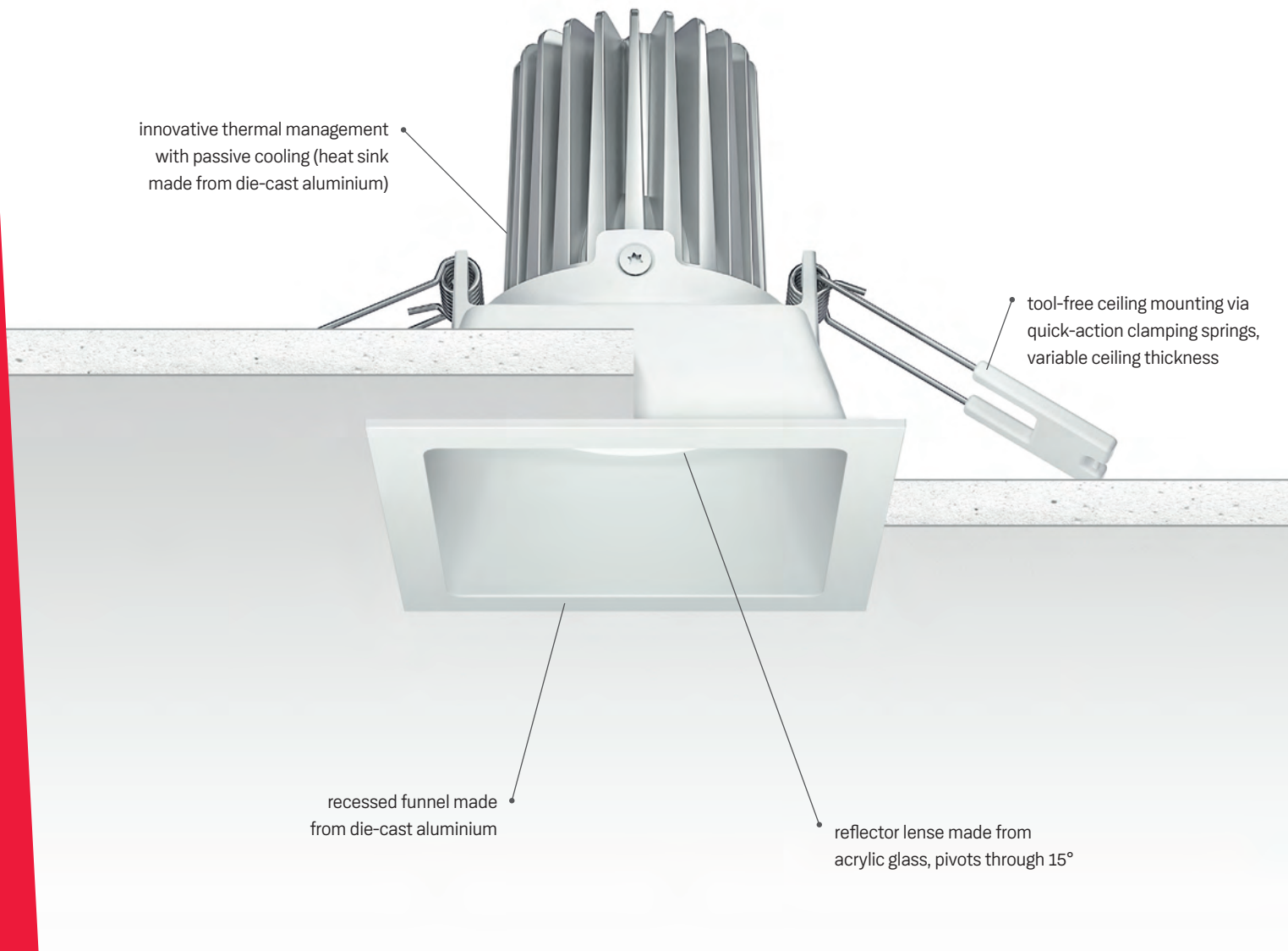

Standard options



Special options







Shan Rahmikhhan, Berlin, GER · Planning: Shan Rahimkhan · Photo: Daniel Horn Photography

## Range selection



| Article name    | L x B [mm] | Colour | Beam angle | CCT [K] | System power [W] | Luminous flux [lm] | Installation depth [mm] | Cut-out [mm] | Ceiling thickness [mm] | Weight [kg] | EEC |
|-----------------|------------|--------|------------|---------|------------------|--------------------|-------------------------|--------------|------------------------|-------------|-----|
| VTSS 10.0530.25 | 80 x 80    | silver | 25°        | 3000    | 12               | 1010               | 112                     | 70 x 70      | 10 - 15                | 0.49        | A+  |
| VTSS 10.0530.35 | 80 x 80    | silver | 35°        | 3000    | 12               | 1050               | 112                     | 70 x 70      | 10 - 15                | 0.49        | A+  |
| VTSS 13.0530.25 | 80 x 80    | white  | 25°        | 3000    | 12               | 1010               | 112                     | 70 x 70      | 10 - 15                | 0.49        | A+  |
| VTSS 13.0530.35 | 80 x 80    | white  | 35°        | 3000    | 12               | 1050               | 112                     | 70 x 70      | 10 - 15                | 0.49        | A+  |
| VTSM 10.0530.25 | 90 x 90    | silver | 25°        | 3000    | 12               | 1080               | 117                     | 78 x 78      | 10 - 15                | 0.52        | A+  |
| VTSM 10.0530.35 | 90 x 90    | silver | 35°        | 3000    | 12               | 1120               | 117                     | 78 x 78      | 10 - 15                | 0.52        | A+  |
| VTSM 13.0530.25 | 90 x 90    | white  | 25°        | 3000    | 12               | 1080               | 117                     | 78 x 78      | 10 - 15                | 0.52        | A+  |
| VTSM 13.0530.35 | 90 x 90    | white  | 35°        | 3000    | 12               | 1120               | 117                     | 78 x 78      | 10 - 15                | 0.52        | A+  |

Further product informations you will find under [www.lts-light.eu/2350](http://www.lts-light.eu/2350) or **2351**

# Vale-Tu Square XSmall

innovative thermal management with passive cooling (heat sink made from die-cast aluminium)

tool-free ceiling mounting via quick-action clamping springs, variable ceiling thickness

mounting frame made from die-cast aluminium

reflector lens made from acrylic glass, pivots through 15°

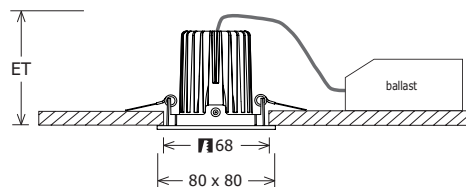

Standard options

|        |      |     |       |
|--------|------|-----|-------|
| 2700 K | DALI | 60° | BLACK |
| 4000 K |      |     |       |

Special options

|                   |
|-------------------|
| CONCRETE RECESSED |
|-------------------|





Wolford, Bregenz, AUT · Planning: Wolford · Photo: Jean-Marc Delettre – Photography

## Range selection



| Article name     | Colour | Beam angle | CCT [K] | System power [W] | Luminous flux [lm] | Installation depth [mm] | Cut-out [mm] | Ceiling thickness [mm] | EEC |
|------------------|--------|------------|---------|------------------|--------------------|-------------------------|--------------|------------------------|-----|
| VTSXS 10.0530.25 | silver | 25°        | 3000    | 12               | 1120               | 87                      | Ø 68         | 10 - 15                | A+  |
| VTSXS 10.0530.35 | silver | 35°        | 3000    | 12               | 1160               | 87                      | Ø 68         | 10 - 15                | A+  |
| VTSXS 13.0530.25 | white  | 25°        | 3000    | 12               | 1120               | 87                      | Ø 68         | 10 - 15                | A+  |
| VTSXS 13.0530.35 | white  | 35°        | 3000    | 12               | 1160               | 87                      | Ø 68         | 10 - 15                | A+  |

Further product informations you will find under [www.lts-light.eu/2352](http://www.lts-light.eu/2352)



# Vario Classic

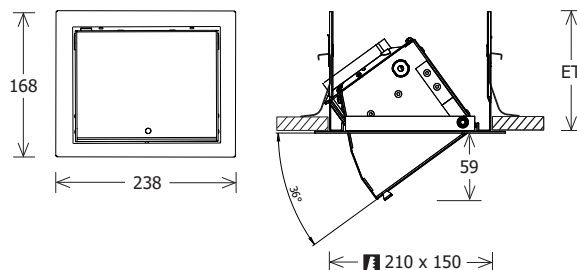
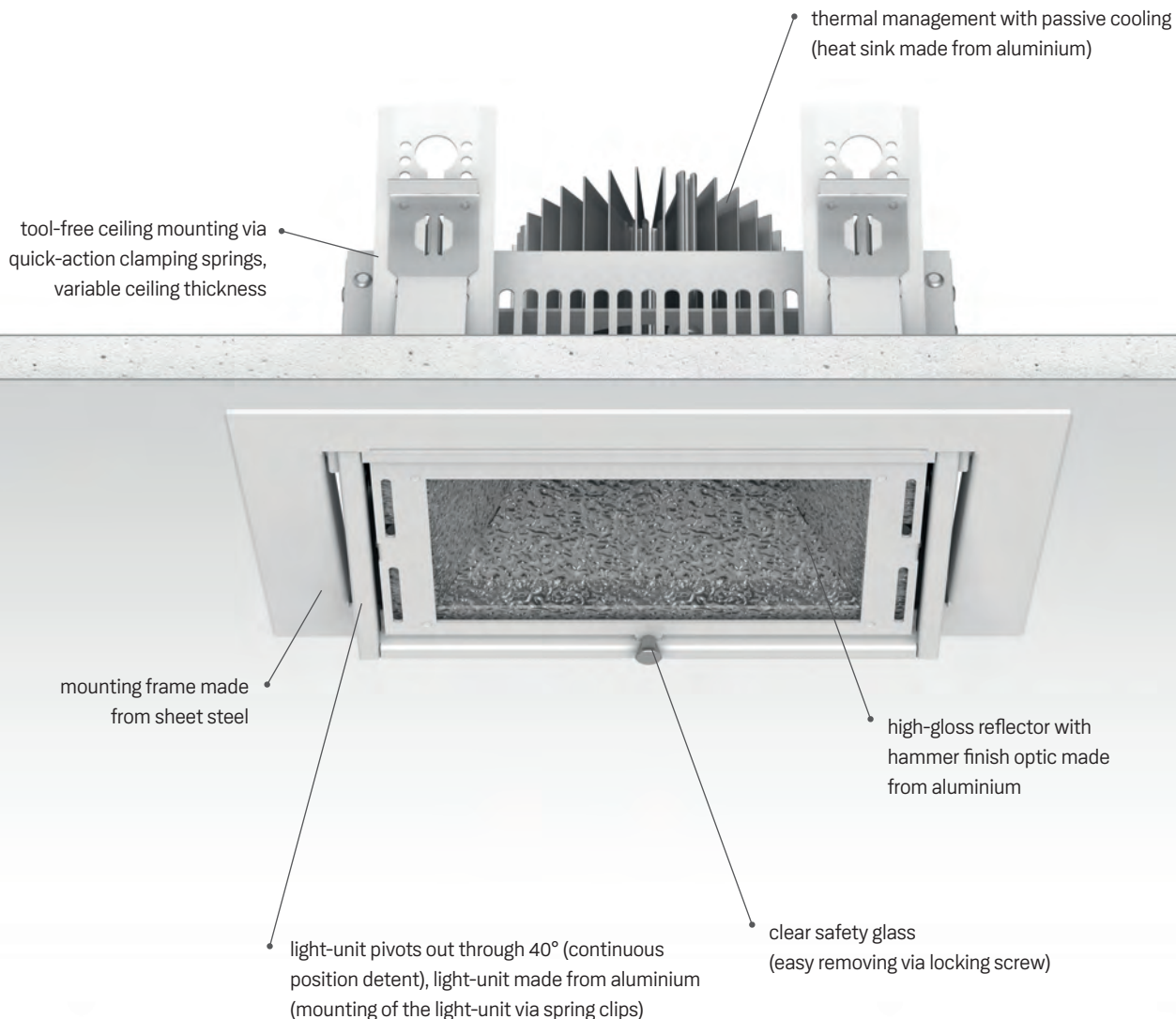

Standard options

|        |      |        |
|--------|------|--------|
| 2700 K | DALI | SILVER |
| 4000 K |      | WHITE  |

Special options

|        |              |     |      |           |         |        |      |         |                   |           |
|--------|--------------|-----|------|-----------|---------|--------|------|---------|-------------------|-----------|
| 3500 K | CRI 90 SDCM3 | TWL | TWPI | MinusBlue | FASHION | BAKERY | MEAT | PRODUCE | CONCRETE RECESSED | BLACK RAL |
|--------|--------------|-----|------|-----------|---------|--------|------|---------|-------------------|-----------|



Bäckerei Metzler, Langenargen, GER · Planning: Brust+Partner

## Range selection



| Article name  | CCT [K] | System power [W] | Luminous flux [lm] | Installation depth [mm] | Cut-out [mm] | Ceiling thickness [mm] | EEC |
|---------------|---------|------------------|--------------------|-------------------------|--------------|------------------------|-----|
| VFCL 700.2530 | 3000    | 27               | 2610               | 135                     | 210 x 150    | 1 - 40                 | A+  |
| VFCL 700.3530 | 3000    | 36               | 3570               | 135                     | 210 x 150    | 1 - 40                 | A+  |
| VFCL 700.5530 | 3000    | 59               | 5450               | 135                     | 210 x 150    | 1 - 40                 | A+  |

Further product informations you will find under [www.its-light.eu/2361](http://www.its-light.eu/2361)





# SURFACE- MOUNTED DOWNLIGHTS

[www.lts-light.com/surface-mounted-downlights](http://www.lts-light.com/surface-mounted-downlights)





# Button 300

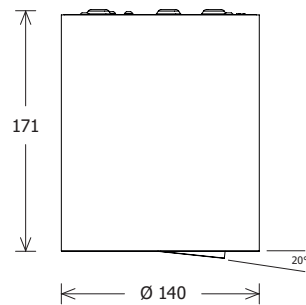

Standard options

|        |      |        |
|--------|------|--------|
| 2700 K | ▲    | BLACK  |
| 4000 K | DALI | SILVER |
|        |      | WHITE  |

Special options

|        |                 |           |         |     |     |     |
|--------|-----------------|-----------|---------|-----|-----|-----|
| 3500 K | CRI 90<br>SDCM3 | MinusBlue | FASHION | 15° | 25° | RAL |
|--------|-----------------|-----------|---------|-----|-----|-----|





Delta Credit, St. Petersburg, RUS

## Range selection



| Article name    | Beam angle | CCT [K] | System power [W] | Luminous flux [lm] | EEC  |
|-----------------|------------|---------|------------------|--------------------|------|
| BTN-A 301.30.35 | 35°        | 3000    | 14               | 1390               | A+ → |
| BTN-A 301.30.50 | 50°        | 3000    | 14               | 1370               | A+ → |
| BTN-A 302.30.50 | 50°        | 3000    | 27               | 2620               | A+ → |
| BTN-A 302.30.35 | 35°        | 3000    | 27               | 2680               | A+ → |

Further product informations you will find under [www.lts-light.eu/2168](http://www.lts-light.eu/2168)



# Button Mini 100/200

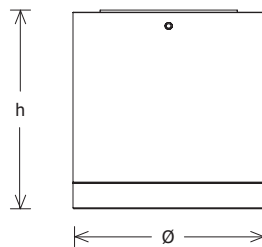

Standard options





Die Wälderin, Mellau, AUT · Planning: elektrodesign Fröhle René · Photo: Leuchtende Hotelfotografie

## Range selection



| Article name   | Ø [mm] | Height [mm] | Beam angle | CCT [K] | System power [W] | Luminous flux [lm] | Weight [kg] | EEC |
|----------------|--------|-------------|------------|---------|------------------|--------------------|-------------|-----|
| BTNM 101.30.55 | 90     | 100         | 55°        | 3000    | 15               | 1200               | 0.54        | A+  |
| BTNM 202.30.55 | 120    | 110         | 55°        | 3000    | 24               | 2400               | 0.83        | A++ |

Further product informations you will find under [www.lts-light.eu/2175](http://www.lts-light.eu/2175) or **2176**



# RECESSED DOWNLIGHTS

[www.lts-light.com/recessed-downlights](http://www.lts-light.com/recessed-downlights)





# Flixx 100/200 Round

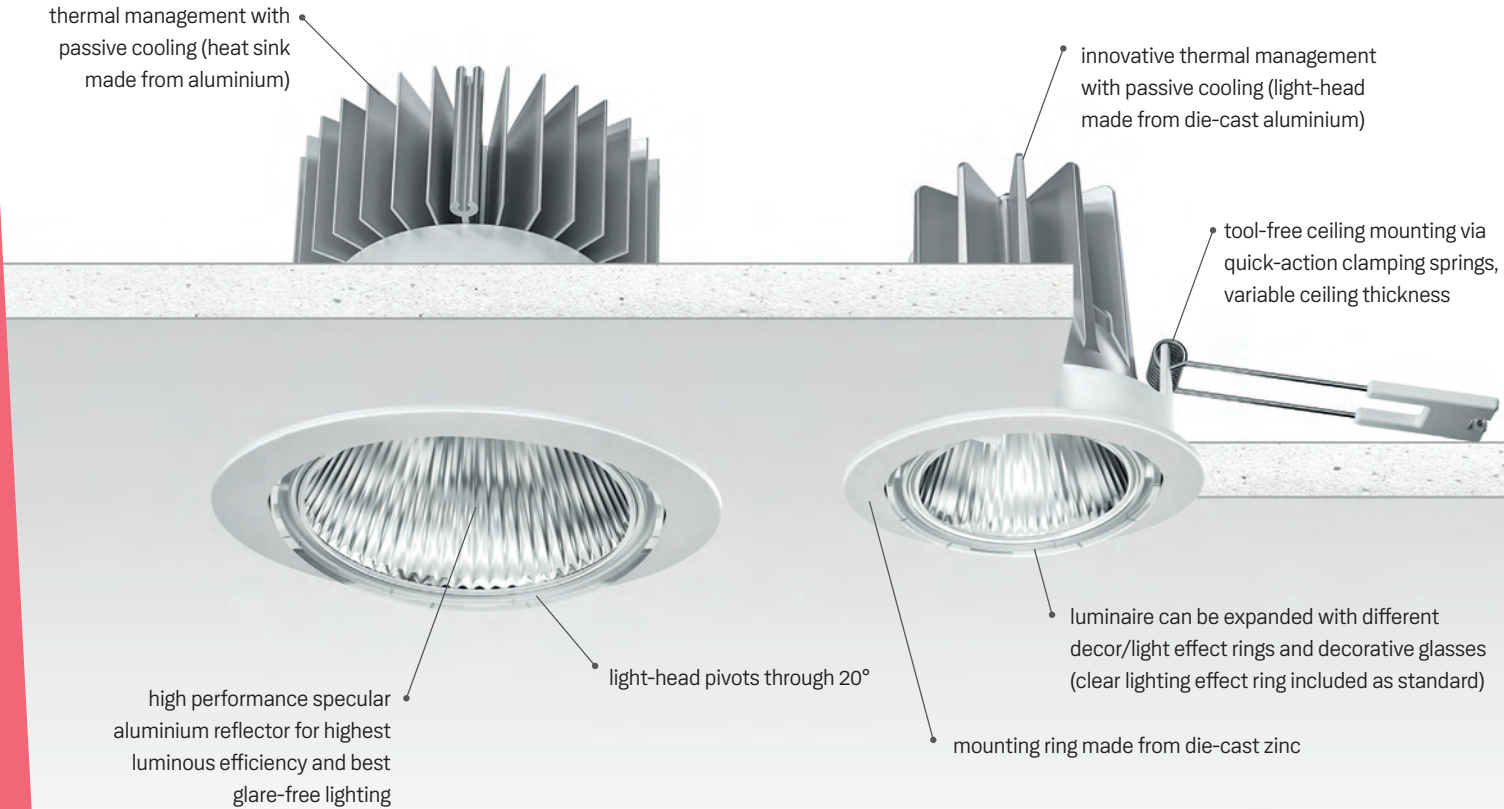

**Note**  
 Also available as larger versions Flixx 300/400 Round (page 106). Special options only available for Flixx 200 Round. Concrete recessed housing possible for Flixx 100/200 Round.

Flixx 200 Round

Flixx 100 Round

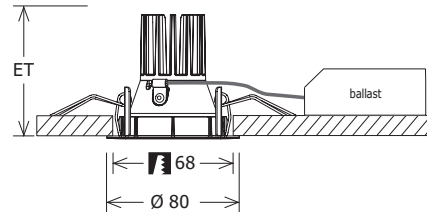
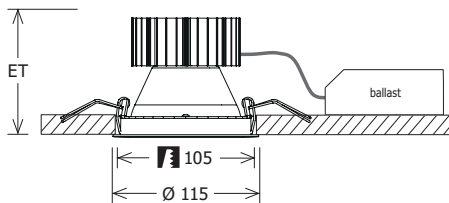

**Standard options**

|        |      |        |
|--------|------|--------|
| 2700 K | DALI | SILVER |
| 4000 K |      | WHITE  |

**Special options**

|              |     |      |           |         |        |      |         |     |                   |       |
|--------------|-----|------|-----------|---------|--------|------|---------|-----|-------------------|-------|
| CRI 90 SDCM3 | TWL | TWPI | MinusBlue | FASHION | BAKERY | MEAT | PRODUCE | 25° | CONCRETE RECESSED | BLACK |
|--------------|-----|------|-----------|---------|--------|------|---------|-----|-------------------|-------|





Hyperion Hotel, Munich, GER · Planning: Unykat Interior Design · Photo: Andreas Huber Fotografie

## Range selection



| Article name     | Ø [mm] | Beam angle | CCT [K] | System power [W] | Luminous flux [lm] | Installation depth [mm] | Cut-out [mm] | Ceiling thickness [mm] | Weight [kg] | EEC   |
|------------------|--------|------------|---------|------------------|--------------------|-------------------------|--------------|------------------------|-------------|-------|
| FLIR 100.1030.15 | 80     | 15°        | 3000    | 15               | 1380               | 90                      | Ø 68         | 1 - 25                 | 0.51        | A+ →  |
| FLIR 100.1030.35 | 80     | 35°        | 3000    | 15               | 1360               | 90                      | Ø 68         | 1 - 25                 | 0.51        | A+ →  |
| FLIR 200.2030.15 | 115    | 15°        | 3000    | 27               | 2970               | 110                     | Ø 105        | 1 - 25                 | 0.87        | A++ → |
| FLIR 200.2030.35 | 115    | 35°        | 3000    | 27               | 2950               | 110                     | Ø 105        | 1 - 25                 | 0.87        | A++ → |
| FLIR 200.2030.50 | 115    | 50°        | 3000    | 27               | 2880               | 110                     | Ø 105        | 1 - 25                 | 0.87        | A++ → |

## Accessories

| Article name                | Description                          |
|-----------------------------|--------------------------------------|
| FLIRZ 100.01 / FLIRZ 200.01 | decorative ring black                |
| FLIRZ 100.02 / FLIRZ 200.02 | decorative ring silver               |
| FLIRZ 100.03 / FLIRZ 200.03 | decorative ring white                |
| FLIRZ 100.04 / FLIRZ 200.04 | light effect ring opal               |
| FLIRZ 100.05 / FLIRZ 200.05 | light effect ring clear              |
| FLIRZ 100.06 / FLIRZ 200.06 | light effect ring red matt           |
| FLIRZ 100.07 / FLIRZ 200.07 | light effect ring yellow matt        |
| FLIRZ 100.08 / FLIRZ 200.08 | light effect ring blue matt          |
| FLIRZ 100.16 / FLIRZ 200.16 | light effect ring red translucent    |
| FLIRZ 100.17 / FLIRZ 200.17 | light effect ring yellow translucent |
| FLIRZ 100.18 / FLIRZ 200.18 | light effect ring blue translucent   |
| FLIRZ 100.24 / FLIRZ 200.24 | decorative glass opal                |
| FLIRZ 100.25 / FLIRZ 200.25 | decorative glass clear               |

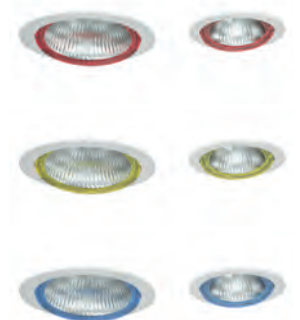

Further product informations you will find under [www.its-light.eu/2142](http://www.its-light.eu/2142) or **2143**



# Flixx 100/200 Square

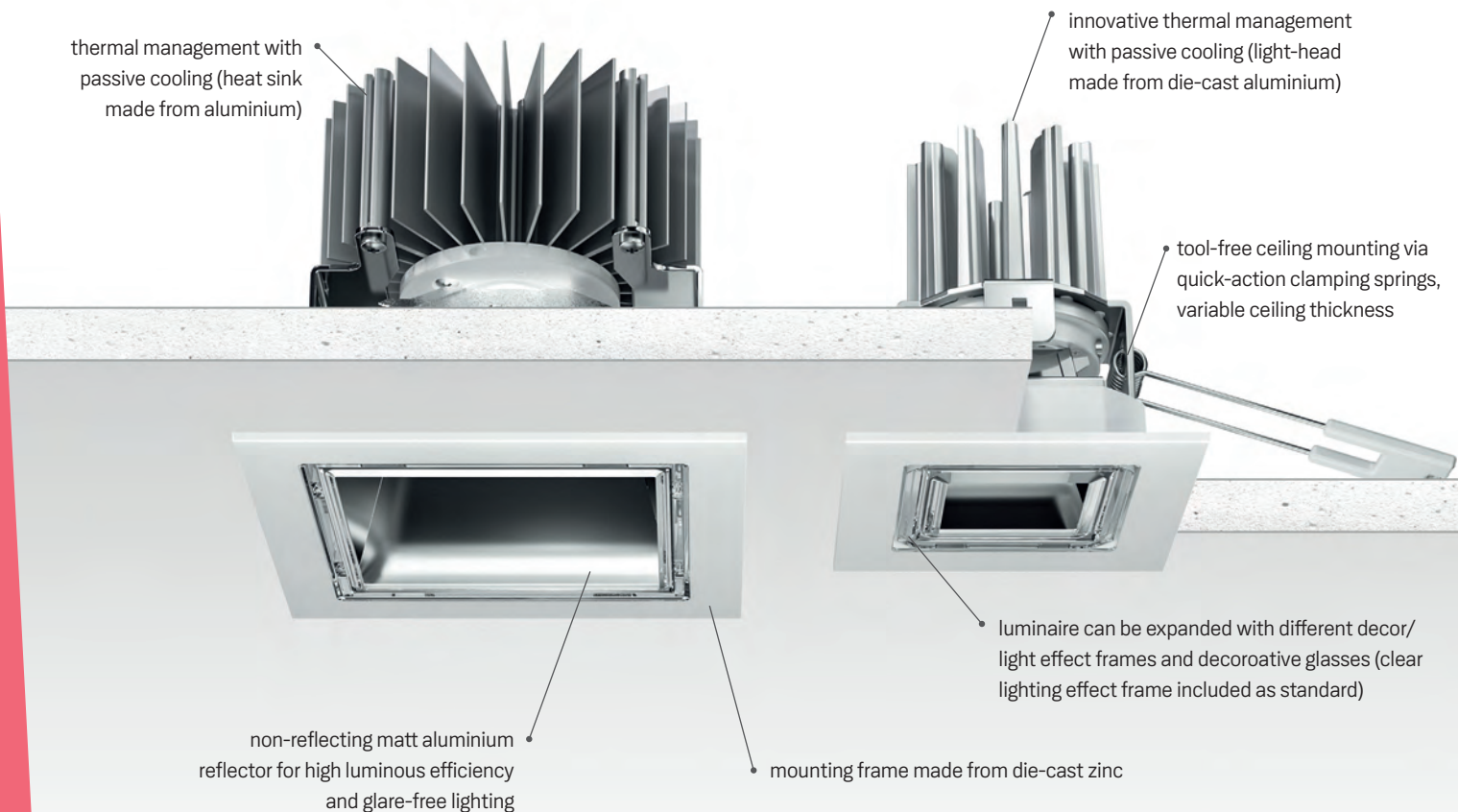

**Note**

Also available as larger versions Flixx 300/400 Square (page 108). Special options only available for Flixx 200 Square. Concrete recessed housing possible for Flixx 100/200 Square.

Flixx 200 Square

Flixx 100 Square

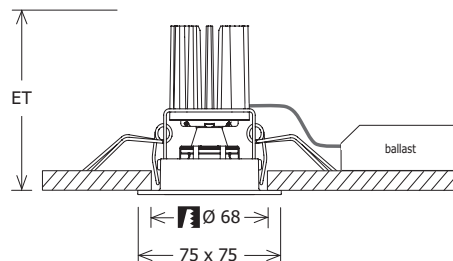
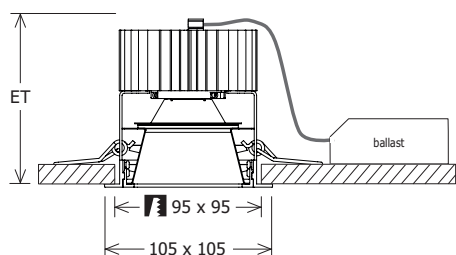

Standard options

|        |      |        |
|--------|------|--------|
| 2700 K | DALI | SILVER |
| 4000 K |      | WHITE  |

Special options

|     |      |           |         |                   |       |
|-----|------|-----------|---------|-------------------|-------|
| TWL | TWPI | MinusBlue | FASHION | CONCRETE RECESSED | BLACK |
|-----|------|-----------|---------|-------------------|-------|



Porsche Zentrum, Wiesbaden, GER · Planning: Ingenieurbüro Amelung & Reydt · Photo: IAF Industrie- und Architektur fotografie

## Range selection



| Article name     | L x B [mm] | CCT [K] | System power [W] | Luminous flux [lm] | Installation depth [mm] | Cut-out [mm] | Ceiling thickness [mm] | Weight [kg] | EEC |
|------------------|------------|---------|------------------|--------------------|-------------------------|--------------|------------------------|-------------|-----|
| FLIQ 100.1030.01 | 75 x 75    | 3000    | 15               | 1160               | 90                      | Ø 68         | 1 - 25                 | 0.58        | A+  |
| FLIQ 200.2030.01 | 105 x 105  | 3000    | 27               | 2670               | 110                     | 95 x 95      | 1 - 25                 | 0.75        | A+  |

## Accessories

| Article name                | Description                           |
|-----------------------------|---------------------------------------|
| FLIQZ 100.01 / FLIQZ 200.01 | decorative frame black                |
| FLIQZ 100.02 / FLIQZ 200.02 | decorative frame silver               |
| FLIQZ 100.03 / FLIQZ 200.03 | decorative frame white                |
| FLIQZ 100.04 / FLIQZ 200.04 | light effect frame opal               |
| FLIQZ 100.05 / FLIQZ 200.05 | light effect frame clear              |
| FLIQZ 100.06 / FLIQZ 200.06 | light effect frame red matt           |
| FLIQZ 100.07 / FLIQZ 200.07 | light effect frame yellow matt        |
| FLIQZ 100.08 / FLIQZ 200.08 | light effect frame blue matt          |
| FLIQZ 100.16 / FLIQZ 200.16 | light effect frame red translucent    |
| FLIQZ 100.17 / FLIQZ 200.17 | light effect frame yellow translucent |
| FLIQZ 100.18 / FLIQZ 200.18 | light effect frame blue translucent   |
| FLIQZ 100.24 / FLIQZ 200.24 | decorative glass opal                 |
| FLIQZ 100.25 / FLIQZ 200.25 | decorative glass clear                |



Further product informations you will find under [www.lts-light.eu/2138](http://www.lts-light.eu/2138) or **2139**

# Flixx 300 Flat Round

innovative thermal management with passive cooling and very small mounting depth (heat sink made from die-cast aluminium)

tool-free ceiling mounting via quick-action clamping springs, variable ceiling thickness

luminaire can be expanded with different decor/light effect rings and decorative glasses (clear lighting effect ring included as standard)

mounting ring made from die-cast zinc

high performance specular aluminium reflector for highest luminous efficiency and best glare-free lighting

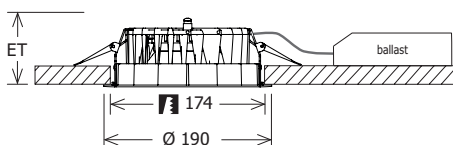

**Standard options**

|        |      |        |
|--------|------|--------|
| 4000 K | DALI | SILVER |
|        |      | WHITE  |

**Special options**

|     |      |                   |                    |       |
|-----|------|-------------------|--------------------|-------|
| TWL | TWPI | CONCRETE RECESSED | EMERGENCY LIGHTING | BLACK |
|-----|------|-------------------|--------------------|-------|





Hyperion Hotel, Munich, GER · Planning: Unykat Interior Design · Photo: Andreas Huber Fotografie

## Range selection



| Article name       | Beam angle | CCT [K] | System power [W] | Luminous flux [lm] | Installation depth [mm] | Cut-out [mm] | Ceiling thickness [mm] | EEC |
|--------------------|------------|---------|------------------|--------------------|-------------------------|--------------|------------------------|-----|
| FLIR-F 300.1030.01 | 85°        | 3000    | 11               | 1020               | 75                      | Ø 174        | 5 - 40                 | A+  |
| FLIR-F 300.2030.01 | 85°        | 3000    | 22               | 1990               | 75                      | Ø 174        | 5 - 40                 | A+  |
| FLIR-F 300.3030.01 | 85°        | 3000    | 29               | 2810               | 75                      | Ø 174        | 5 - 40                 | A+  |

## Accessories

| Article name     | Description  |
|------------------|--|
| FLIRZ 300.01     | decorative ring black                                |
| FLIRZ 300.02     | decorative ring silver                               |
| FLIRZ 300.03     | decorative ring white                                |
| FLIRZ 300.04     | light effect ring opal                               |
| FLIRZ 300.05     | light effect ring clear                              |
| FLIRZ 300.06     | light effect ring red matt                           |
| FLIRZ 300.07     | light effect ring yellow matt                        |
| FLIRZ 300.08     | light effect ring blue matt                          |
| FLIRZ 300.16     | light effect ring red translucent                    |
| FLIRZ 300.17     | light effect ring yellow translucent                 |
| FLIRZ 300.18     | light effect ring blue translucent                   |
| FLIRZ 300.24     | decorative glass opal                                |
| FLIRZ 300.25     | decorative glass clear                               |
| NOL 50B/3H/DALI  | LED emergency light-unit                             |
| ZDAR 175.215-275 | spacing ring for ceiling cut-outs from 215 to 275 mm |
| ZVP 100          | universal reinforcement frame (module 625 x 625)     |

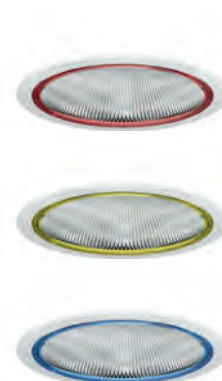

Further product informations you will find under [www.its-light.eu/2169](http://www.its-light.eu/2169)

# Flixx 300/400 Round

innovative thermal management with passive cooling (heat sink made from die-cast aluminium)

tool-free ceiling mounting via automatic quick clamping, variable ceiling thickness

mounting ring made from die-cast zinc

luminaire can be expanded with different decor/light effect rings and decorative glasses (clear lighting effect ring included as standard)

high performance specular aluminium reflector for highest luminous efficiency and best glare-free lighting

**Note**

Also available as smaller versions **Flixx 100/200 Round** (page 100). In addition the version **Flixx Flat 300 Round** (page 104) with very small installation depth or wall-washer **Flixx 320** (page 110) are available.

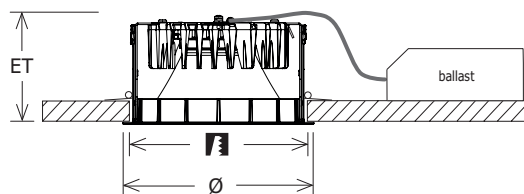

**Standard options**

|        |      |        |
|--------|------|--------|
| 4000 K | DALI | SILVER |
|        |      | WHITE  |

**Special options**

|     |      |                   |                    |       |
|-----|------|-------------------|--------------------|-------|
| TWL | TWPI | CONCRETE RECESSED | EMERGENCY LIGHTING | BLACK |
|-----|------|-------------------|--------------------|-------|



Stadtwerke Stade, GER · Planning: scandal architecture & interiors · Photo: scandal architecture & interiors



## Range selection

| Article name     | Ø [mm] | Beam angle | CCT [K] | System power [W] | Luminous flux [lm] | UGR  | Installation depth [mm] | Cut-out [mm] | Ceiling thickness [mm] | Weight [kg] | EEC |
|------------------|--------|------------|---------|------------------|--------------------|------|-------------------------|--------------|------------------------|-------------|-----|
| FLIR 300.1030.01 | 188    | 75°        | 3000    | 11               | 1070               | 16.4 | 105                     | Ø 175        | 5 - 50                 | 1.14        | A+  |
| FLIR 300.2030.01 | 188    | 75°        | 3000    | 21               | 2110               | 18.7 | 105                     | Ø 175        | 5 - 50                 | 1.16        | A+  |
| FLIR 300.3030.01 | 188    | 75°        | 3000    | 26               | 2790               |      | 105                     | Ø 175        | 5 - 50                 | 1.16        | A++ |
| FLIR 400.2030.01 | 220    | 75°        | 3000    | 21               | 2170               |      | 105                     | Ø 210        | 5 - 50                 | 1.25        | A+  |
| FLIR 400.3030.01 | 220    | 75°        | 3000    | 26               | 2870               |      | 105                     | Ø 210        | 5 - 50                 | 1.25        | A++ |

## Accessories

| Article name                | Description   |
|-----------------------------|---|
| FLIRZ 300.01 / FLIRZ 400.01 | decorative ring black   |
| FLIRZ 300.02 / FLIRZ 400.02 | decorative ring silver  |
| FLIRZ 300.03 / FLIRZ 400.03 | decorative ring white   |
| FLIRZ 300.04 / FLIRZ 400.04 | light effect ring opal  |
| FLIRZ 300.05 / FLIRZ 400.05 | light effect ring clear                                       |
| FLIRZ 300.06 / FLIRZ 400.06 | light effect ring red matt                                    |
| FLIRZ 300.07 / FLIRZ 400.07 | light effect ring yellow matt                                 |
| FLIRZ 300.08 / FLIRZ 400.08 | light effect ring blue matt                                   |
| FLIRZ 300.16 / FLIRZ 400.16 | light effect ring red translucent                             |
| FLIRZ 300.17 / FLIRZ 400.17 | light effect ring yellow translucent                          |
| FLIRZ 300.18 / FLIRZ 400.18 | light effect ring blue translucent                            |
| FLIRZ 300.24 / FLIRZ 400.24 | decorative glass opal   |
| FLIRZ 300.25 / FLIRZ 400.25 | decorative glass clear  |
| NOL 50B/3H/DALI             | emergency light-unit  |
| ZDAR 175.215-275            | FLIR 300 spacing ring for ceiling cut-outs from 215 to 275 mm |
| ZDAR 207.250-310            | FLIR 400 spacing ring for ceiling cut-outs from 250 to 310 mm |
| ZVP 100                     | universal reinforcement frame (module 625 x 625)              |

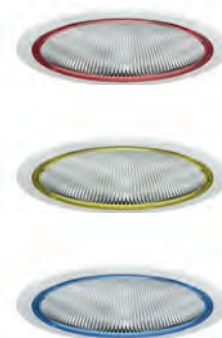

Further product informations you will find under [www.its-light.eu/2144](http://www.its-light.eu/2144) or **2145**



# Flixx 300/400 Square

innovative thermal management with passive cooling (heat sink made from die-cast aluminium)

tool-free ceiling mounting via automatic quick clamping, variable ceiling thickness

mounting frame made from die-cast zinc

non-reflecting matt aluminium reflector for high luminous efficiency and glare-free lighting

luminaire can be expanded with different decor/light effect frames and decorative glasses (clear lighting effect frame included as standard)

**Note**  
Also available as smaller versions Flixx 100/200 Square (page 102).

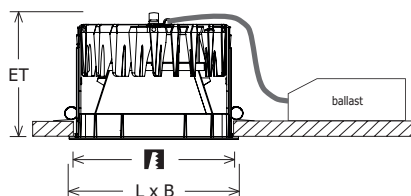

**Standard options**

|        |      |        |
|--------|------|--------|
| 4000 K | DALI | SILVER |
|        |      | WHITE  |

**Special options**

|     |      |                   |                    |       |
|-----|------|-------------------|--------------------|-------|
| TWL | TWPI | CONCRETE RECESSED | EMERGENCY LIGHTING | BLACK |
|-----|------|-------------------|--------------------|-------|



LEO Pharma, Dubai, UAE

## Range selection



| Article name     | L x B [mm] | CCT [K] | System power [W] | Luminous flux [lm] | UGR  | Installation depth [mm] | Cut-out [mm] | Ceiling thickness [mm] | Weight [kg] | EEC |
|------------------|------------|---------|------------------|--------------------|------|-------------------------|--------------|------------------------|-------------|-----|
| FLIQ 300.1030.01 | 145 x 145  | 3000    | 11               | 1010               | 17,9 | 110                     | 140 x 140    | 5 - 50                 | 1.14        | A+  |
| FLIQ 300.2030.01 | 145 x 145  | 3000    | 21               | 2070               |      | 110                     | 140 x 140    | 5 - 50                 | 1.21        | A+  |
| FLIQ 300.3030.01 | 145 x 145  | 3000    | 26               | 2720               |      | 110                     | 140 x 140    | 5 - 50                 | 1.21        | A+  |
| FLIQ 400.2030.01 | 200 x 200  | 3000    | 21               | 2450               |      | 110                     | 188 x 188    | 5 - 50                 | 1.40        | A++ |
| FLIQ 400.3030.01 | 200 x 200  | 3000    | 26               | 3240               |      | 110                     | 188 x 188    | 5 - 50                 | 1.37        | A++ |

## Accessories

| Article name                | Description                                      |
|-----------------------------|--|
| FLIQZ 300.01 / FLIQZ 400.01 | decorative frame black                           |
| FLIQZ 300.02 / FLIQZ 400.02 | decorative frame silver                          |
| FLIQZ 300.03 / FLIQZ 400.03 | decorative frame white                           |
| FLIQZ 300.04 / FLIQZ 400.04 | light effect frame opal                          |
| FLIQZ 300.05 / FLIQZ 400.05 | light effect frame clear                         |
| FLIQZ 300.06 / FLIQZ 400.06 | light effect frame red matt                      |
| FLIQZ 300.07 / FLIQZ 400.07 | light effect frame yellow matt                   |
| FLIQZ 300.08 / FLIQZ 400.08 | light effect frame blue matt                     |
| FLIQZ 300.16 / FLIQZ 400.16 | light effect frame red translucent               |
| FLIQZ 300.17 / FLIQZ 400.17 | light effect frame yellow translucent            |
| FLIQZ 300.18 / FLIQZ 400.18 | light effect frame blue translucent              |
| FLIQZ 300.24 / FLIQZ 400.24 | decorative glass opal                            |
| FLIQZ 300.25 / FLIQZ 400.25 | decorative glass clear                           |
| NOL 50B/3H/DALI             | emergency light-unit                             |
| ZVP 100                     | universal reinforcement frame (module 625 x 625) |

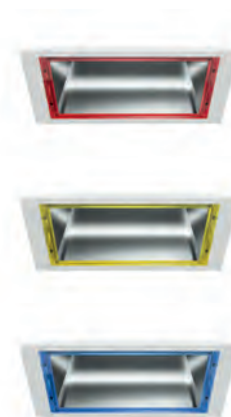

Further product informations you will find under [www.its-light.eu/2140](http://www.its-light.eu/2140) or **2141**

# Flixx 320 Round Wallwasher

innovative thermal management with passive cooling (heat sink made from die-cast aluminium)

tool-free ceiling mounting via automatic quick clamping, variable ceiling thickness

mounting ring made from die-cast zinc

high-gloss reflector made from anodised PBT with protective coat of scratch-resistant lacquer, asymmetrical light distribution for uniform lighting on vertical surfaces, avoiding of dark spots where the wall and ceiling meets

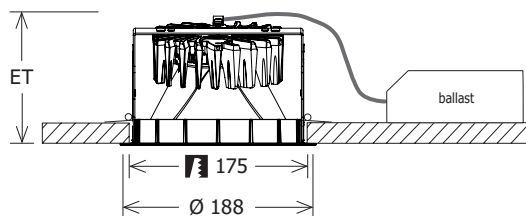

### Standard options

|        |      |        |
|--------|------|--------|
| 4000 K | DALI | SILVER |
|        |      | WHITE  |

### Special options

|     |                   |       |
|-----|-------------------|-------|
| TWL | CONCRETE RECESSED | BLACK |
|-----|-------------------|-------|





Delta Credit, St. Petersburg, RUS

## Range selection



| Article name     | CCT [K] | System power [W] | Luminous flux [lm] | Installation depth [mm] | Cut-out [mm] | Ceiling thickness [mm] | EEC |
|------------------|---------|------------------|--------------------|-------------------------|--------------|------------------------|-----|
| FLIR 320.2030.01 | 3000    | 21               | 1730               | 120                     | Ø 175        | 5 - 50                 | A+  |

Further product informations you will find under [www.lts-light.eu/2179](http://www.lts-light.eu/2179)

# Torpedo 250

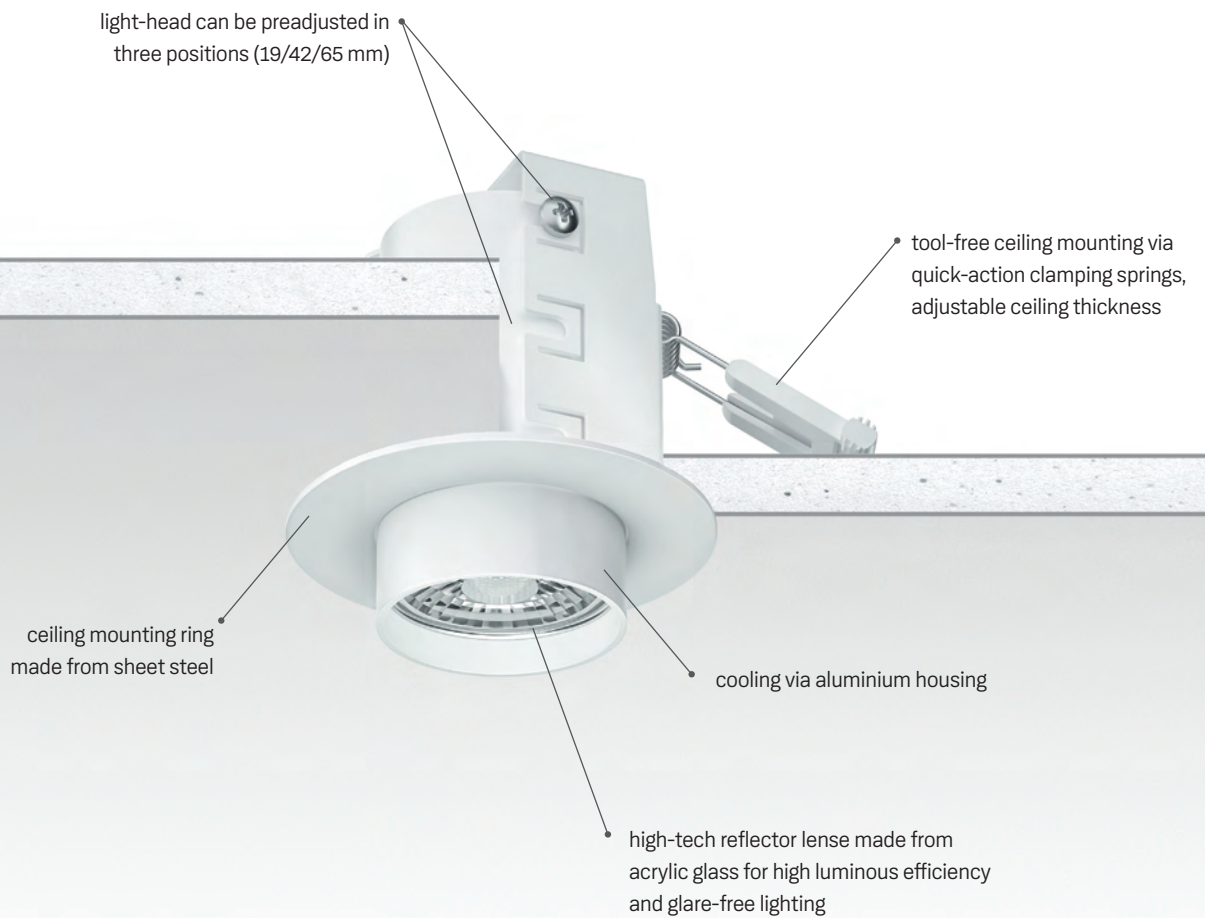

**Note**  
Also available as larger version  
Torpedo 350 (page 114).

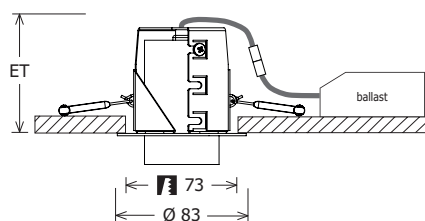

**Standard options**

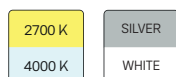

**Special options**





## Range selection



| Article name    | Beam angle | CCT [K] | System power [W] | Luminous flux [lm] | Installation depth [mm] | Cut-out [mm] | Ceiling thickness [mm] | EEC |
|-----------------|------------|---------|------------------|--------------------|-------------------------|--------------|------------------------|-----|
| TORL 251.830.25 | 25°        | 3000    | 12               | 1030               | 68                      | Ø 73         | 1 - 20                 | A+  |
| TORL 251.830.40 | 40°        | 3000    | 12               | 1100               | 68                      | Ø 73         | 1 - 20                 | A+  |
| TORL 251.830.55 | 55°        | 3000    | 12               | 760                | 68                      | Ø 73         | 1 - 20                 | A   |

Further product informations you will find under [www.lts-light.eu/2177](http://www.lts-light.eu/2177)



# Torpedo 350



**Note**  
**Also available as smaller version**  
**Torpedo 250 (page 112).**

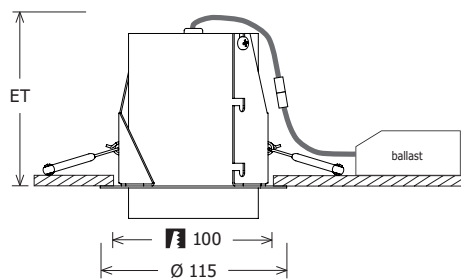

**Standard options**

|        |      |        |
|--------|------|--------|
| 2700 K | DALI | SILVER |
| 4000 K |      | WHITE  |

**Special options**

|        |                 |           |         |              |
|--------|-----------------|-----------|---------|--------------|
| 3500 K | CRI 90<br>SDCM3 | MinusBlue | FASHION | BLACK<br>RAL |
|--------|-----------------|-----------|---------|--------------|



## Range selection



| Article name    | Beam angle | CCT [K] | System power [W] | Luminous flux [lm] | Installation depth [mm] | Cut-out [mm] | Ceiling thickness [mm] | EEC |
|-----------------|------------|---------|------------------|--------------------|-------------------------|--------------|------------------------|-----|
| TORL 351.830.15 | 15°        | 3000    | 13               | 1320               | 110                     | Ø 100        | 1 - 20                 | A++ |
| TORL 351.830.25 | 25°        | 3000    | 13               | 1320               | 110                     | Ø 100        | 1 - 20                 | A++ |
| TORL 351.830.35 | 35°        | 3000    | 13               | 1310               | 110                     | Ø 100        | 1 - 20                 | A+  |
| TORL 351.830.45 | 45°        | 3000    | 13               | 1290               | 110                     | Ø 100        | 1 - 20                 | A+  |
| TORL 352.830.15 | 15°        | 3000    | 26               | 2630               | 110                     | Ø 100        | 1 - 20                 | A++ |
| TORL 352.830.25 | 25°        | 3000    | 26               | 2620               | 110                     | Ø 100        | 1 - 20                 | A+  |
| TORL 352.830.35 | 35°        | 3000    | 26               | 2610               | 110                     | Ø 100        | 1 - 20                 | A+  |
| TORL 352.830.45 | 45°        | 3000    | 26               | 2580               | 110                     | Ø 100        | 1 - 20                 | A+  |

## Accessories

| Article name | Description      |
|--------------|------------------|
| ZBW 85       | honeycomb louvre |

Further product informations you will find under [www.its-light.eu/2178](http://www.its-light.eu/2178)

# Vale-Tu Flat

innovative thermal management with passive cooling and very small mounting depth (heat sink made from die-cast aluminium)

tool-free ceiling mounting via quick-action clamping springs, variable ceiling thickness

mounting ring made from die-cast aluminium

opal microprismatic diffuser

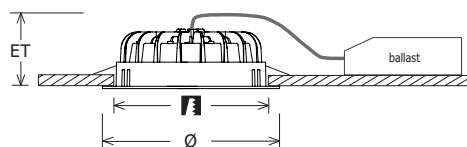

## Standard options

|        |      |        |
|--------|------|--------|
| 2700 K | DALI | SILVER |
| 4000 K |      | WHITE  |

## Special options

|     |                   |       |
|-----|-------------------|-------|
| TWL | CONCRETE RECESSED | BLACK |
|-----|-------------------|-------|





Die Wälderin, Mellau, AUT · Planning: elektrodesign Fröhle René · Photo: Leuchtende Hotelfotografie

## Range selection



| Article name | Ø [mm] | CCT [K] | System power [W] | Luminous flux [lm] | Installation depth [mm] | Cut-out [mm] | Ceiling thickness [mm] | Weight [kg] | EEC |
|--------------|--------|---------|------------------|--------------------|-------------------------|--------------|------------------------|-------------|-----|
| VTFS 10.1030 | 158    | 3000    | 15               | 1050               | 70                      | Ø 142        | 1 - 25                 | 0.52        | A   |
| VTFM 10.1530 | 200    | 3000    | 21               | 1720               | 70                      | Ø 175        | 1 - 20                 | 0.84        | A+  |
| VTFL 10.2530 | 230    | 3000    | 32               | 2850               | 70                      | Ø 205        | 1 - 20                 | 1.00        | A+  |

## Accessories

| Article name     | Description   |
|------------------|---|
| ZDAR 145.165-225 | VTFS spacing ring for ceiling cut-outs from 165 to 225 mm |
| ZDAR 175.215-275 | VTFM spacing ring for ceiling cut-outs from 215 to 275 mm |
| ZDAR 207.250-310 | VTFL spacing ring for ceiling cut-outs from 250 to 310 mm |

Further product informations you will find under [www.lts-light.eu/2154](http://www.lts-light.eu/2154), [2153](http://www.lts-light.eu/2153) or [2152](http://www.lts-light.eu/2152)

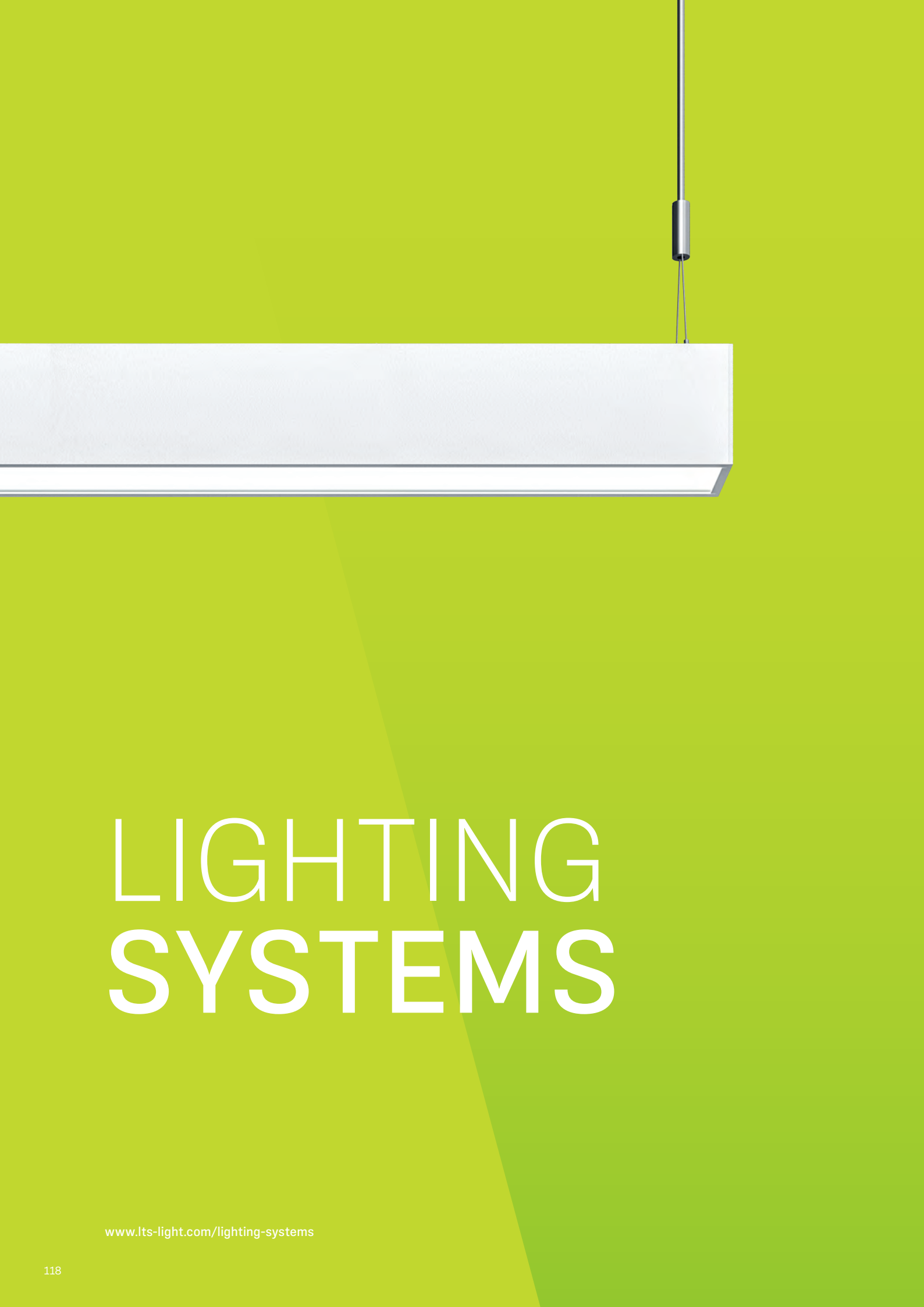

# LIGHTING SYSTEMS

[www.lts-light.com/lighting-systems](http://www.lts-light.com/lighting-systems)







# StraitLine 60

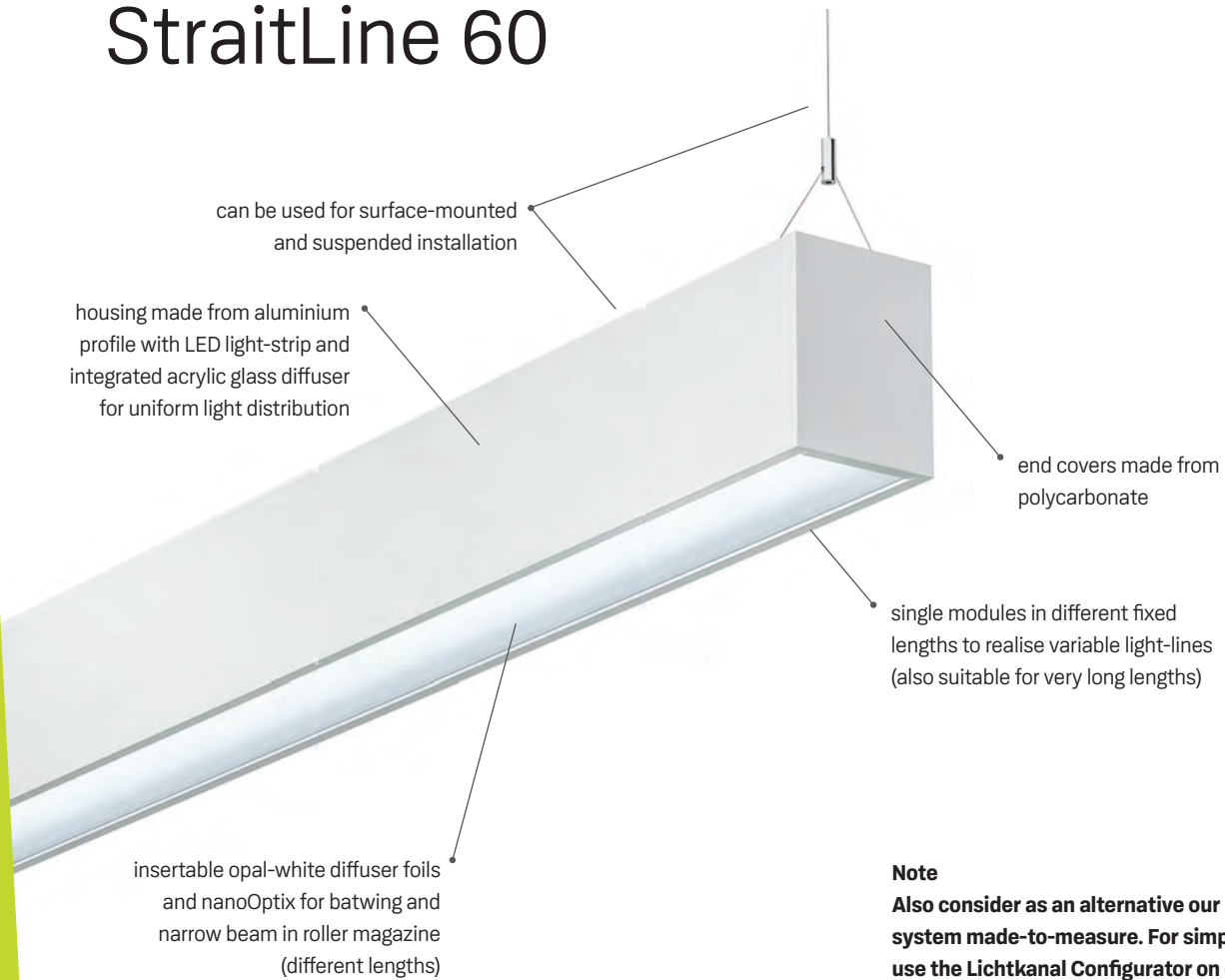

**Note**

Also consider as an alternative our Lichtkanal system made-to-measure. For simple planning use the Lichtkanal Configurator on our website. Further informations on page 142.

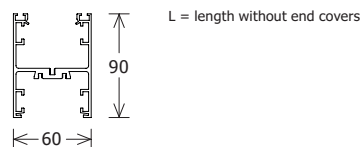
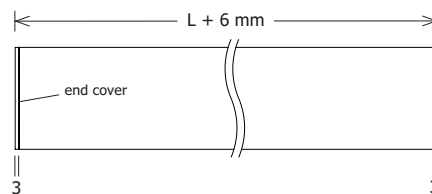

**Standard options**



**Special options**





Jaguar Landrover Classic Cars, Essen, GER · Planning: Hamacher Daub & Partner · Photo: Jaguar Land Rover Classic Deutschland



## Range selection

| Article name   | Length [mm] | CCT [K] | System power [W] | Luminous flux [lm] | Weight [kg] | Feature                                 | EEC |
|----------------|-------------|---------|------------------|--------------------|-------------|---|-----|
| STRL 607.40.03 | 845         | 4000    | 13               | 1320               | 2.55        | not suitable for mounting spotlight     | A+  |
| STRL 607.40.04 | 1125        | 4000    | 18               | 1750               | 3.33        | suitable for max. 1 mounting spotlight  | A+  |
| STRL 607.40.05 | 1405        | 4000    | 22               | 2190               | 3.88        | suitable for max. 2 mounting spotlights | A+  |
| STRL 607.40.08 | 2250        | 4000    | 34               | 3500               | 6.37        | suitable for max. 2 mounting spotlights | A+  |
| STRL 607.40.12 | 3375        | 4000    | 51               | 5250               | 9.34        | suitable for max. 3 mounting spotlights | A+  |
| STRL 610.40.03 | 845         | 4000    | 26               | 2620               | 2.55        | not suitable for mounting spotlight     | A+  |
| STRL 610.40.04 | 1125        | 4000    | 35               | 3500               | 3.33        | suitable for max. 1 mounting spotlight  | A+  |
| STRL 610.40.05 | 1405        | 4000    | 43               | 4370               | 3.88        | suitable for max. 2 mounting spotlights | A+  |
| STRL 610.40.08 | 2250        | 4000    | 68               | 6990               | 6.37        | suitable for max. 2 mounting spotlights | A+  |
| STRL 610.40.12 | 3375        | 4000    | 102              | 10480              | 9.34        | suitable for max. 3 mounting spotlights | A+  |
| STRL 611.40.03 | 845         | 4000    | 46               | 4450               | 2.55        | not suitable for mounting spotlight     | A+  |
| STRL 611.40.04 | 1125        | 4000    | 62               | 5930               | 3.33        | suitable for max. 1 mounting spotlight  | A+  |
| STRL 611.40.05 | 1405        | 4000    | 77               | 7410               | 3.88        | suitable for max. 2 mounting spotlights | A+  |
| STRL 611.40.08 | 2250        | 4000    | 124              | 11860              | 6.37        | suitable for max. 2 mounting spotlights | A+  |
| STRL 611.40.12 | 3375        | 4000    | 186              | 17790              | 9.34        | suitable for max. 3 mounting spotlights | A+  |

## Accessories

| Article name          | Description  |
|-----------------------|--|
| STRL 690.100.05       | feeder with plug-ready cable (3-core, length: 5000 mm) in black, transparent or white                                    |
| STRL 690.101          | end cover (2 pieces, thickness of end cover: 3 mm) in grey, black or white   |
| STRL 690.102          | mechanical connectors (4 pieces)   |
| STRL 690.103.03       | wire-rope suspension (2 pieces, length: 3000 mm)   |
| STRL 690.104          | surface-mounting clamps (2 pieces, mounting distance: max. 2000 mm) in silver, black or white                            |
| STRL-LK060 690.120.xx | foil Wide Beam with different lengths in roller magazine (length: 3/5/10/15/25/30 m, opal, can be shortened)             |
| STRL-LK060 690.123.xx | foil nanoOptix Batwing with different lengths in roller magazine (length: 3/5/10/15/25/30 m, opal, can be shortened)     |
| STRL-LK060 690.126.xx | foli nanoOptix Narrow Beam with different lengths in roller magazine (length: 3/5/10/15/25/30 m, opal, can be shortened) |
| STRL 690.130.03       | dust cover made from opal acrylic glass (length: 845 mm, not suitable in combination with mounting spotlights)           |
| STRL 690.130.04       | dust cover made from opal acrylic glass (length: 1125 mm, not suitable in combination with mounting spotlights)          |
| STRL 690.130.05       | dust cover made from opal acrylic glass (length: 1405 mm, not suitable in combination with mounting spotlights)          |
| STRL 690.130.08       | dust cover made from opal acrylic glass (length: 2250 mm, not suitable in combination with mounting spotlights)          |
| STRL 690.130.12       | dust cover made from opal acrylic glass (length: 3375 mm, not suitable in combination with mounting spotlights)          |

Further product informations you will find under [www.its-light.eu/2824](http://www.its-light.eu/2824)

# StraitLine 60 Spot

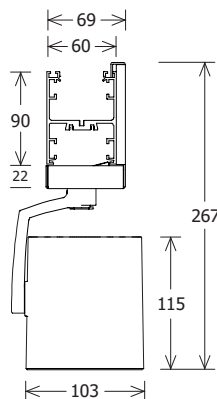

**Standard options**

|        |      |                          |
|--------|------|--------------------------|
| 3000 K | DALI | BLACK<br>SILVER<br>WHITE |
|--------|------|--------------------------|

**Special options**

|                  |                 |     |           |         |        |      |         |     |     |
|------------------|-----------------|-----|-----------|---------|--------|------|---------|-----|-----|
| 2700 K<br>3500 K | CRI 90<br>SDCM3 | TWL | MinusBlue | FASHION | BAKERY | MEAT | PRODUCE | 15° | RAL |
|------------------|-----------------|-----|-----------|---------|--------|------|---------|-----|-----|





Pursuits Menswear, Freiburg, GER · Planung: Rosens · Photo: Enrique Salcedo Puerto

## Range selection



| Article name     | Beam angle | CCT [K] | System power [W] | Luminous flux [lm] | EEC |
|------------------|------------|---------|------------------|--------------------|-----|
| STRL-J 103.40.25 | 25°        | 4000    | 30               | 3430               | A++ |
| STRL-J 103.40.35 | 35°        | 4000    | 30               | 3350               | A++ |
| STRL-J 103.40.50 | 50°        | 4000    | 30               | 3120               | A++ |
| STRL-J 105.40.25 | 25°        | 4000    | 50               | 5760               | A++ |
| STRL-J 105.40.35 | 35°        | 4000    | 50               | 5700               | A++ |
| STRL-J 105.40.50 | 50°        | 4000    | 50               | 5230               | A++ |

## Accessories

| Article name | Description   |
|--------------|---|
| FOCUS 100.1  | superior optic with focusable biconvex lens for accent lighting |
| ZBK 96       | anti-glare flaps  |
| ZBW 83       | honeycomb louvre  |



Further product informations you will find under [www.lts-light.eu/2825](http://www.lts-light.eu/2825)



# CEILING & PENDANT LUMINAIRES

[www.lts-light.com/ceiling-and-pendant-luminaires](http://www.lts-light.com/ceiling-and-pendant-luminaires)







# Lunata Direct-Indirect

with Light Effect Ring

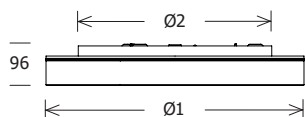

**Standard options**



**Special options**

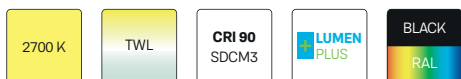



Stiftung Liebenau, Meckenbeuren, GER · Planning: Ingenieurbüro Werner Schwarz

## Range selection



| Article name            | Feature        | Ø [mm]               | CCT [K] | System power [W] | Luminous flux [lm] | Fixing                        | Weight [kg] | EEC |
|-------------------------|----------------|----------------------|---------|------------------|--------------------|-------------------------------|-------------|-----|
| LUNXXS 40.010.40.1/DALI | Lunata XXSmall | Ø1 = 315 / Ø2 = 213  | 4000    | 11               | 1150               | L 83/1500 DIM / L 83/1500 DIM | 2.97        | A++ |
| LUNXXS 40.020.40.1/DALI | Lunata XXSmall | Ø1 = 315 / Ø2 = 213  | 4000    | 21               | 2170               | L 83/1500 DIM / L 83/1500 DIM | 2.97        | A++ |
| LUNXS 40.020.40.1/DALI  | Lunata XSmall  | Ø1 = 400 / Ø2 = 213  | 4000    | 12               | 1250               | L 83/1500 DIM / L 83/1500 DIM | 4.12        | A++ |
| LUNXS 40.040.40.1/DALI  | Lunata XSmall  | Ø1 = 400 / Ø2 = 213  | 4000    | 22               | 2280               | L 83/1500 DIM / L 83/1500 DIM | 4.12        | A++ |
| LUNS 40.025.40.1/DALI   | Lunata Small   | Ø1 = 556 / Ø2 = 450  | 4000    | 19               | 2240               | L 72/1500 DIM / L 72/3000 DIM | 8.04        | A++ |
| LUNS 40.040.40.1/DALI   | Lunata Small   | Ø1 = 556 / Ø2 = 450  | 4000    | 38               | 4480               | L 72/1500 DIM / L 72/3000 DIM | 8.04        | A++ |
| LUNM 40.040.40.1/DALI   | Lunata Medium  | Ø1 = 856 / Ø2 = 675  | 4000    | 36               | 4520               | L 72/3000 DIM                 | 14.90       | A++ |
| LUNM 40.060.40.1/DALI   | Lunata Medium  | Ø1 = 856 / Ø2 = 675  | 4000    | 72               | 9040               | L 72/3000 DIM                 | 14.90       | A++ |
| LUNL 40.060.40.1/DALI   | Lunata Large   | Ø1 = 1134 / Ø2 = 910 | 4000    | 49               | 6650               | L 82/3000 DIM                 | 25.86       | A++ |
| LUNL 40.115.40.1/DALI   | Lunata Large   | Ø1 = 1134 / Ø2 = 910 | 4000    | 98               | 13290              | L 82/3000 DIM                 | 25.86       | A++ |

## Accessories

| Article name  | Description   |
|---------------|---|
| L 83/1500 DIM | wire-rope suspension 3-fold (length: 1500 mm, 5-core cable) |
| L 83/3000 DIM | wire-rope suspension 3-fold (length: 3000 mm, 5-core cable) |
| L 72/1500 DIM | wire-rope suspension 4-fold (length: 1500 mm, 5-core cable) |
| L 72/3000 DIM | wire-rope suspension 4-fold (length: 3000 mm, 5-core cable) |
| L 82/3000 DIM | wire-rope suspension 6-fold (length: 3000 mm, 5-core cable) |

Further product informations you will find under [www.lts-light.eu/2421](http://www.lts-light.eu/2421), [2429](http://www.lts-light.eu/2429), [2415](http://www.lts-light.eu/2415), [2416](http://www.lts-light.eu/2416) or [2417](http://www.lts-light.eu/2417)

# Lunata Direct

without Light Effect Ring

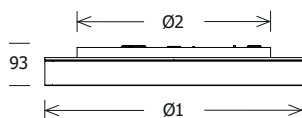

Standard options



Special options

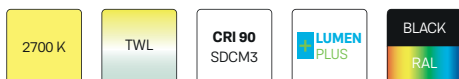





LO-Borgen, Stockholm, SE · Photo: Stockholms Enskilda Reklambyrå

## Range selection



| Article name            | Feature        | Ø [mm]               | CCT [K] | System power [W] | Luminous flux [lm] | Fixing                        | Weight [kg] | EEC |
|-------------------------|----------------|----------------------|---------|------------------|--------------------|-------------------------------|-------------|-----|
| LUNXXS 10.010.40.1/DALI | Lunata XXSmall | Ø1 = 315 / Ø2 = 213  | 4000    | 11               | 1150               | L 83/1500 DIM / L 83/1500 DIM | 2.97        | A++ |
| LUNXXS 10.020.40.1/DALI | Lunata XXSmall | Ø1 = 315 / Ø2 = 213  | 4000    | 21               | 2170               | L 83/1500 DIM / L 83/1500 DIM | 2.97        | A++ |
| LUNXS 10.020.40.1/DALI  | Lunata XSmall  | Ø1 = 400 / Ø2 = 213  | 4000    | 12               | 1250               | L 83/1500 DIM / L 83/1500 DIM | 4.12        | A++ |
| LUNXS 10.040.40.1/DALI  | Lunata XSmall  | Ø1 = 400 / Ø2 = 213  | 4000    | 22               | 2280               | L 83/1500 DIM / L 83/1500 DIM | 4.12        | A++ |
| LUNS 10.025.40.1/DALI   | Lunata Small   | Ø1 = 556 / Ø2 = 450  | 4000    | 19               | 2240               | L 72/1500 DIM / L 72/3000 DIM | 8.04        | A++ |
| LUNS 10.040.40.1/DALI   | Lunata Small   | Ø1 = 556 / Ø2 = 450  | 4000    | 38               | 4480               | L 72/1500 DIM / L 72/3000 DIM | 8.04        | A++ |
| LUNM 10.040.40.1/DALI   | Lunata Medium  | Ø1 = 856 / Ø2 = 675  | 4000    | 36               | 4520               | L 72/3000 DIM                 | 14.90       | A++ |
| LUNM 10.060.40.1/DALI   | Lunata Medium  | Ø1 = 856 / Ø2 = 675  | 4000    | 72               | 9040               | L 72/3000 DIM                 | 14.90       | A++ |
| LUNL 10.060.40.1/DALI   | Lunata Large   | Ø1 = 1134 / Ø2 = 910 | 4000    | 49               | 6650               | L 82/3000 DIM                 | 25.86       | A++ |
| LUNL 10.115.40.1/DALI   | Lunata Large   | Ø1 = 1134 / Ø2 = 910 | 4000    | 98               | 13290              | L 82/3000 DIM                 | 25.86       | A++ |

## Accessories

| Article name  | Description   |
|---------------|---|
| L 83/1500 DIM | wire-rope suspension 3-fold (length: 1500 mm, 5-core cable) |
| L 83/3000 DIM | wire-rope suspension 3-fold (length: 3000 mm, 5-core cable) |
| L 72/1500 DIM | wire-rope suspension 4-fold (length: 1500 mm, 5-core cable) |
| L 72/3000 DIM | wire-rope suspension 4-fold (length: 3000 mm, 5-core cable) |
| L 82/3000 DIM | wire-rope suspension 6-fold (length: 3000 mm, 5-core cable) |

Further product informations you will find under [www.lts-light.eu/2429](http://www.lts-light.eu/2429), [2421](http://www.lts-light.eu/2421), [2415](http://www.lts-light.eu/2415), [2416](http://www.lts-light.eu/2416) or [2417](http://www.lts-light.eu/2417)

# LUZ

## Surface-Mounted

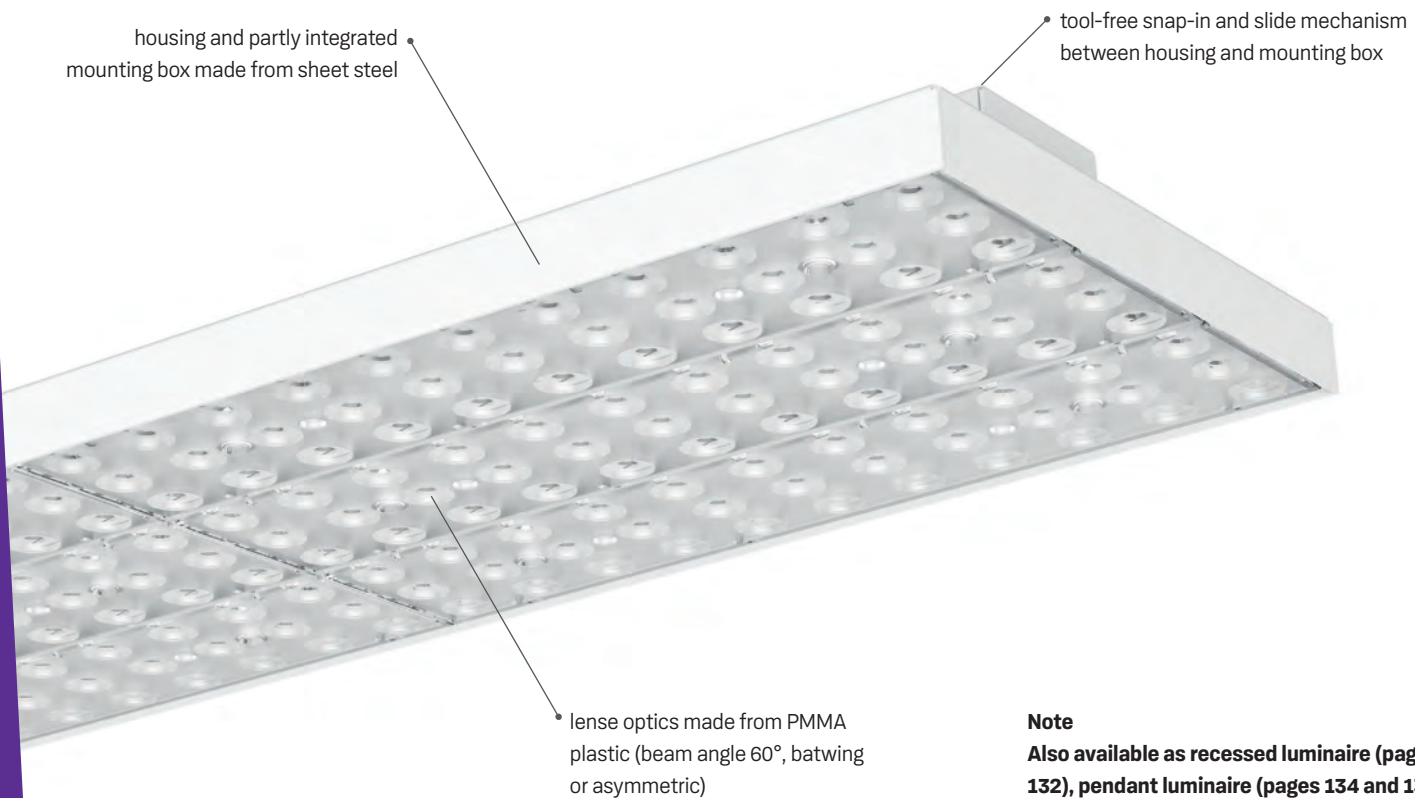

**Note**  
 Also available as recessed luminaire (page 132), pendant luminaire (pages 134 and 138) or track-mounted luminaire (page 136).

1-row

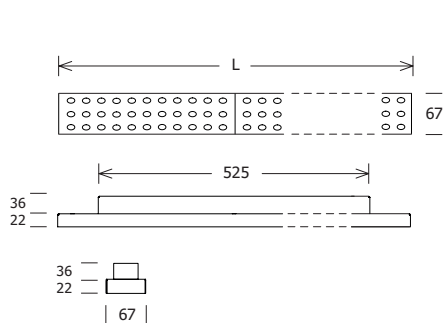

2-row

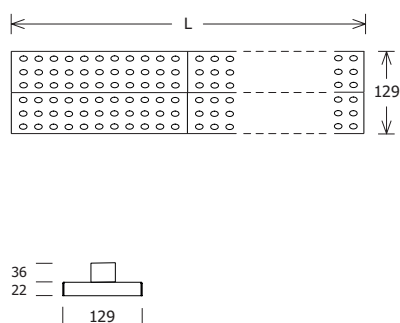

3-row

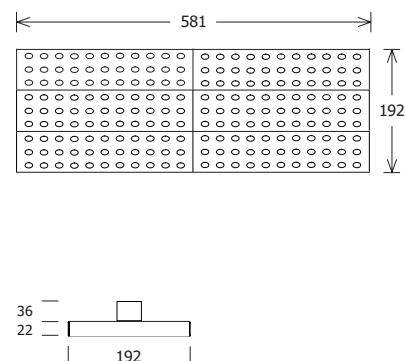

Standard options

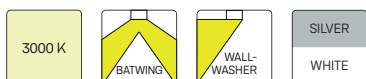

Special options







ritter. architekten + planungsbüro, Bochum, GER · Photo: BECKDESIGN

## Range selection



| Article name      | Feature                       | L x B [mm] | CCT [K] | System power [W] | Luminous flux [lm] | Weight [kg] | EEC |
|-------------------|-------------------------------|------------|---------|------------------|--------------------|-------------|-----|
| LUZ06-A 12.007.40 | 1-row/2-length, power stage 1 | 581 x 67   | 4000    | 12               | 1650               | 1.68        | A++ |
| LUZ06-A 12.013.40 | 1-row/2-length, power stage 2 | 581 x 67   | 4000    | 24               | 3290               | 1.68        | A++ |
| LUZ06-A 13.007.40 | 1-row/3-length, power stage 1 | 867 x 67   | 4000    | 18               | 2470               | 2.31        | A++ |
| LUZ06-A 13.013.40 | 1-row/3-length, power stage 2 | 867 x 67   | 4000    | 36               | 4940               | 2.31        | A++ |
| LUZ06-A 14.007.40 | 1-row/4-length, power stage 1 | 1153 x 67  | 4000    | 24               | 3290               | 2.63        | A++ |
| LUZ06-A 14.013.40 | 1-row/4-length, power stage 2 | 1153 x 67  | 4000    | 48               | 6580               | 2.63        | A++ |
| LUZ06-A 15.007.40 | 1-row/5-length, power stage 1 | 1439 x 67  | 4000    | 30               | 4110               | 3.13        | A++ |
| LUZ06-A 15.013.40 | 1-row/5-length, power stage 2 | 1439 x 67  | 4000    | 60               | 8220               | 3.13        | A++ |
| LUZ06-A 22.007.40 | 2-row/2-length, power stage 1 | 581 x 129  | 4000    | 24               | 3290               | 2.43        | A++ |
| LUZ06-A 22.013.40 | 2-row/2-length, power stage 2 | 581 x 129  | 4000    | 48               | 6580               | 2.43        | A++ |
| LUZ06-A 23.007.40 | 2-row/3-length, power stage 1 | 867 x 129  | 4000    | 36               | 4940               | 3.23        | A++ |
| LUZ06-A 23.013.40 | 2-row/3-length, power stage 2 | 867 x 129  | 4000    | 72               | 9870               | 3.23        | A++ |
| LUZ06-A 32.007.40 | 3-row/2-length, power stage 1 | 581 x 192  | 4000    | 36               | 4940               | 3.23        | A++ |
| LUZ06-A 32.013.40 | 3-row/2-length, power stage 2 | 581 x 192  | 4000    | 72               | 9870               | 3.23        | A++ |

Further product informations you will find under [www.its-light.eu/2430](http://www.its-light.eu/2430)



# LUZ

## Recessed Standard

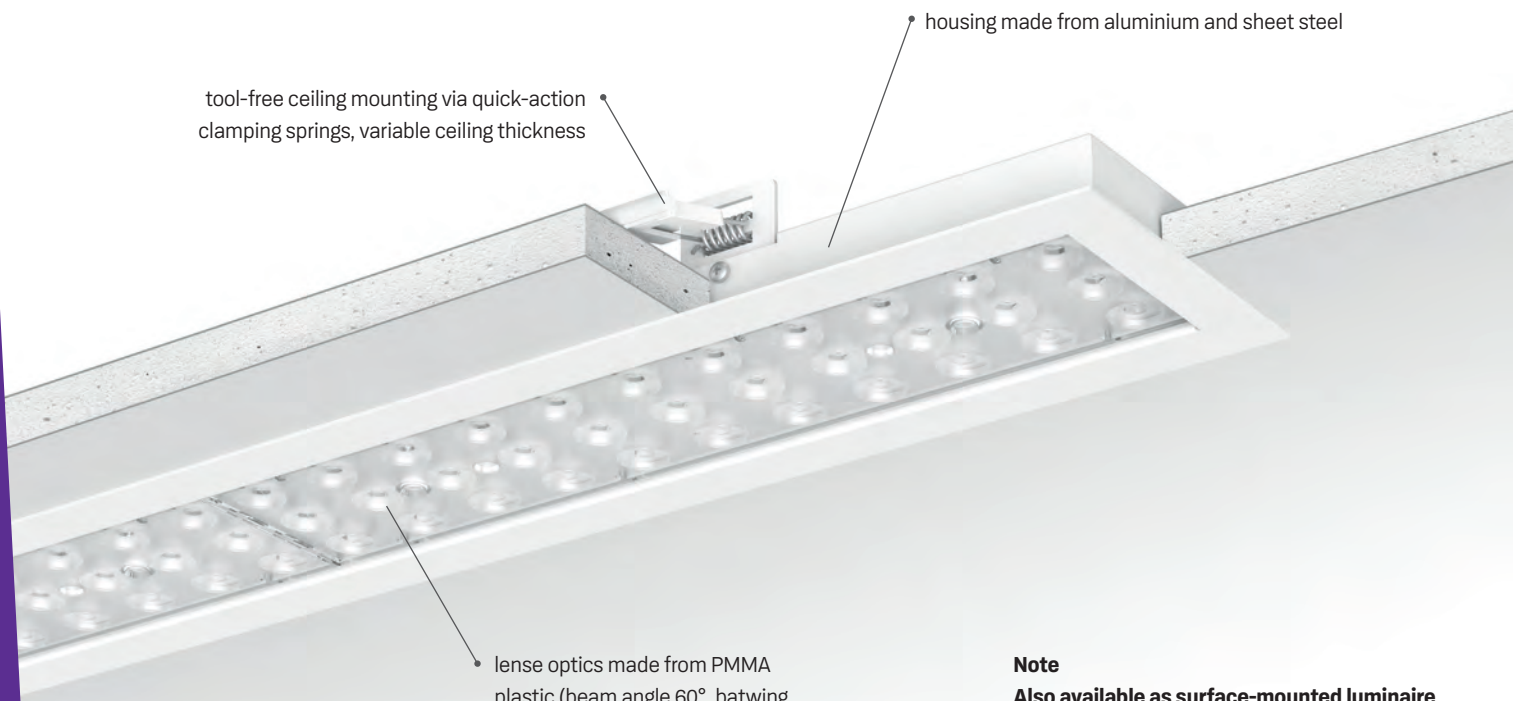

**Note**  
 Also available as surface-mounted luminaire (page 130), pendant luminaire (pages 134 and 138) or track-mounted luminaire (page 136).

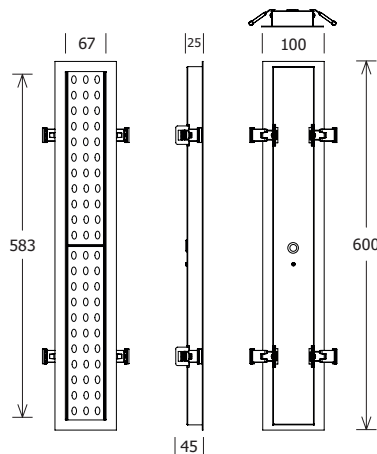

**Standard options**



**Special options**





## Range selection



| Article name        | Feature                       | CCT [K] | System power [W] | Luminous flux [lm] | UGR  | Installation depth [mm] | Cut-out [mm] | Ceiling thickness [mm] | EEC |
|---------------------|-------------------------------|---------|------------------|--------------------|------|-------------------------|--------------|------------------------|-----|
| LUZ06M-ES 12.013.40 | 1-row/2-length, power stage 1 | 4000    | 25               | 3290               | 19.0 | 90                      | 588 x 80     | 1 - 25                 | A++ |
| LUZ06M-ES 12.019.40 | 1-row/2-length, power stage 2 | 4000    | 37               | 4780               |      | 90                      | 588 x 80     | 1 - 25                 | A++ |

Further product informations you will find under [www.lts-light.eu/2438](http://www.lts-light.eu/2438)

# LUZ

## Pendant

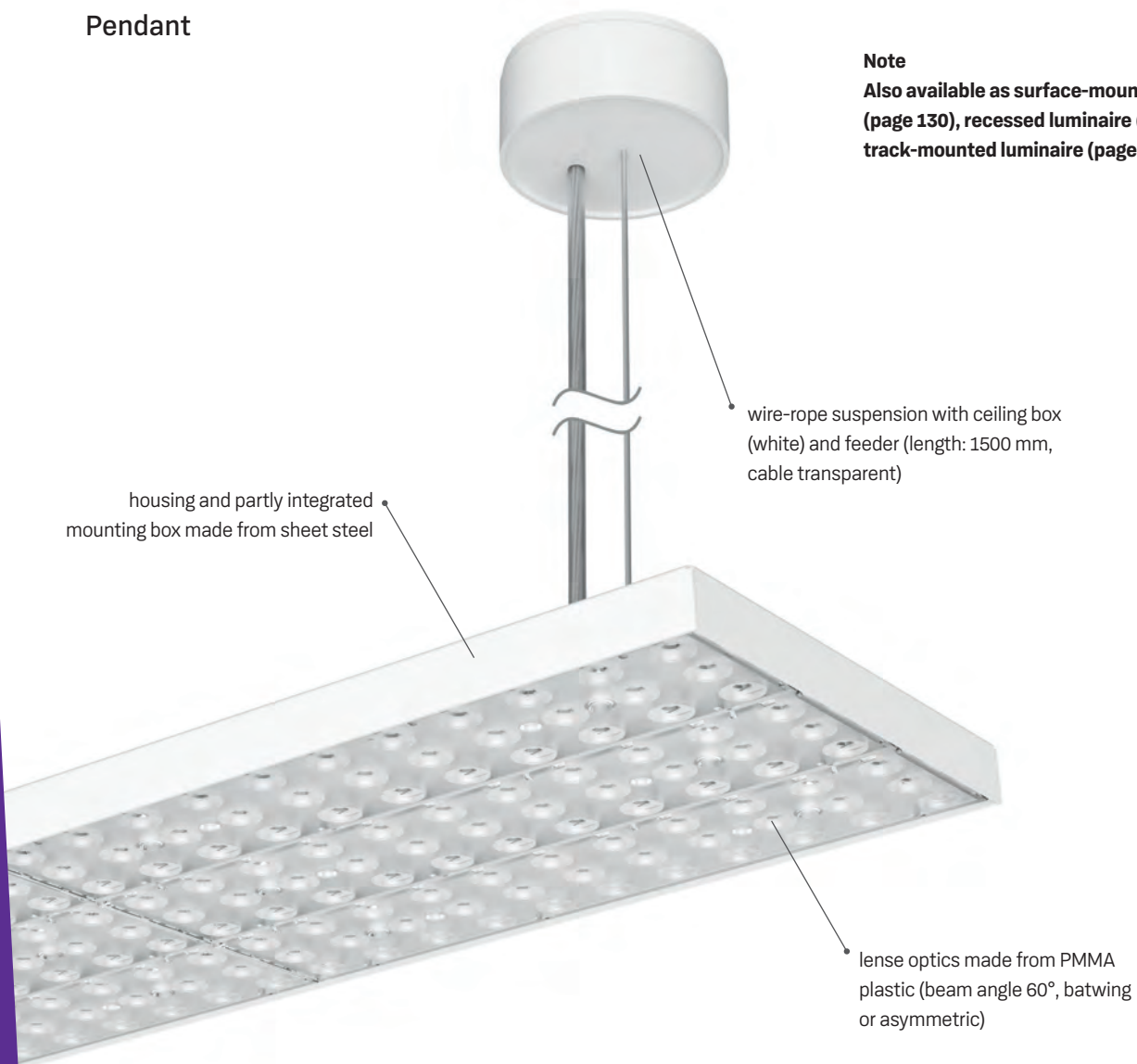

**Note**

Also available as surface-mounted luminaire (page 130), recessed luminaire (page 132) or track-mounted luminaire (pages 136 and 138).

housing and partly integrated mounting box made from sheet steel

wire-rope suspension with ceiling box (white) and feeder (length: 1500 mm, cable transparent)

lense optics made from PMMA plastic (beam angle 60°, batwing or asymmetric)

1-row

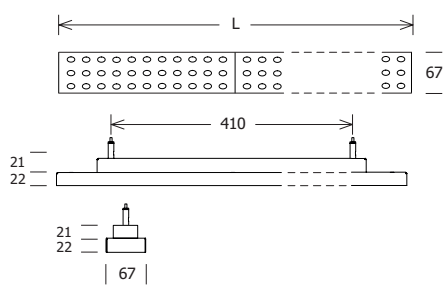

2-row

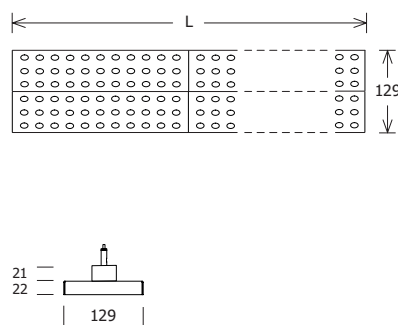

3-row

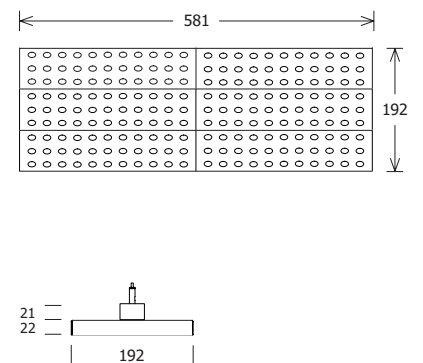

**Standard options**

|  |  |  |  |
|--|--|--|--|
|  |  |  |  |
|  |  |  |  |

**Special options**

|  |  |  |  |  |
|--|--|--|--|--|
|  |  |  |  |  |
|  |  |  |  |  |





## Range selection



| Article name      | Feature                       | L x B [mm] | CCT [K] | System power [W] | Luminous flux [lm] | Weight [kg] | EEC |
|-------------------|-------------------------------|------------|---------|------------------|--------------------|-------------|-----|
| LUZ06-D 12.007.40 | 1-row/2-length, power stage 1 | 581 x 67   | 4000    | 12               | 1650               | 2.01        | A++ |
| LUZ06-D 12.013.40 | 1-row/2-length, power stage 2 | 581 x 67   | 4000    | 24               | 3290               | 2.01        | A++ |
| LUZ06-D 13.007.40 | 1-row/3-length, power stage 1 | 867 x 67   | 4000    | 18               | 2470               | 2.64        | A++ |
| LUZ06-D 13.013.40 | 1-row/3-length, power stage 2 | 867 x 67   | 4000    | 36               | 4940               | 2.64        | A++ |
| LUZ06-D 14.007.40 | 1-row/4-length, power stage 1 | 1153 x 67  | 4000    | 24               | 3290               | 3.09        | A++ |
| LUZ06-D 14.013.40 | 1-row/4-length, power stage 2 | 1153 x 67  | 4000    | 48               | 6580               | 3.09        | A++ |
| LUZ06-D 15.007.40 | 1-row/5-length, power stage 1 | 1439 x 67  | 4000    | 30               | 4110               | 3.67        | A++ |
| LUZ06-D 15.013.40 | 1-row/5-length, power stage 2 | 1439 x 67  | 4000    | 60               | 8220               | 3.67        | A++ |
| LUZ06-D 22.007.40 | 2-row/2-length, power stage 1 | 581 x 129  | 4000    | 24               | 3290               | 2.76        | A++ |
| LUZ06-D 22.013.40 | 2-row/2-length, power stage 2 | 581 x 129  | 4000    | 48               | 6580               | 2.76        | A++ |
| LUZ06-D 23.007.40 | 2-row/3-length, power stage 1 | 867 x 129  | 4000    | 36               | 4940               | 3.61        | A++ |
| LUZ06-D 23.013.40 | 2-row/3-length, power stage 2 | 867 x 129  | 4000    | 72               | 9870               | 3.61        | A++ |
| LUZ06-D 32.007.40 | 3-row/2-length, power stage 1 | 581 x 192  | 4000    | 36               | 4940               | 3.61        | A++ |
| LUZ06-D 32.013.40 | 3-row/2-length, power stage 2 | 581 x 192  | 4000    | 72               | 9870               | 3.61        | A++ |

Further product informations you will find under [www.lts-light.eu/2645](http://www.lts-light.eu/2645)

# LUZ

## Track-Mounted

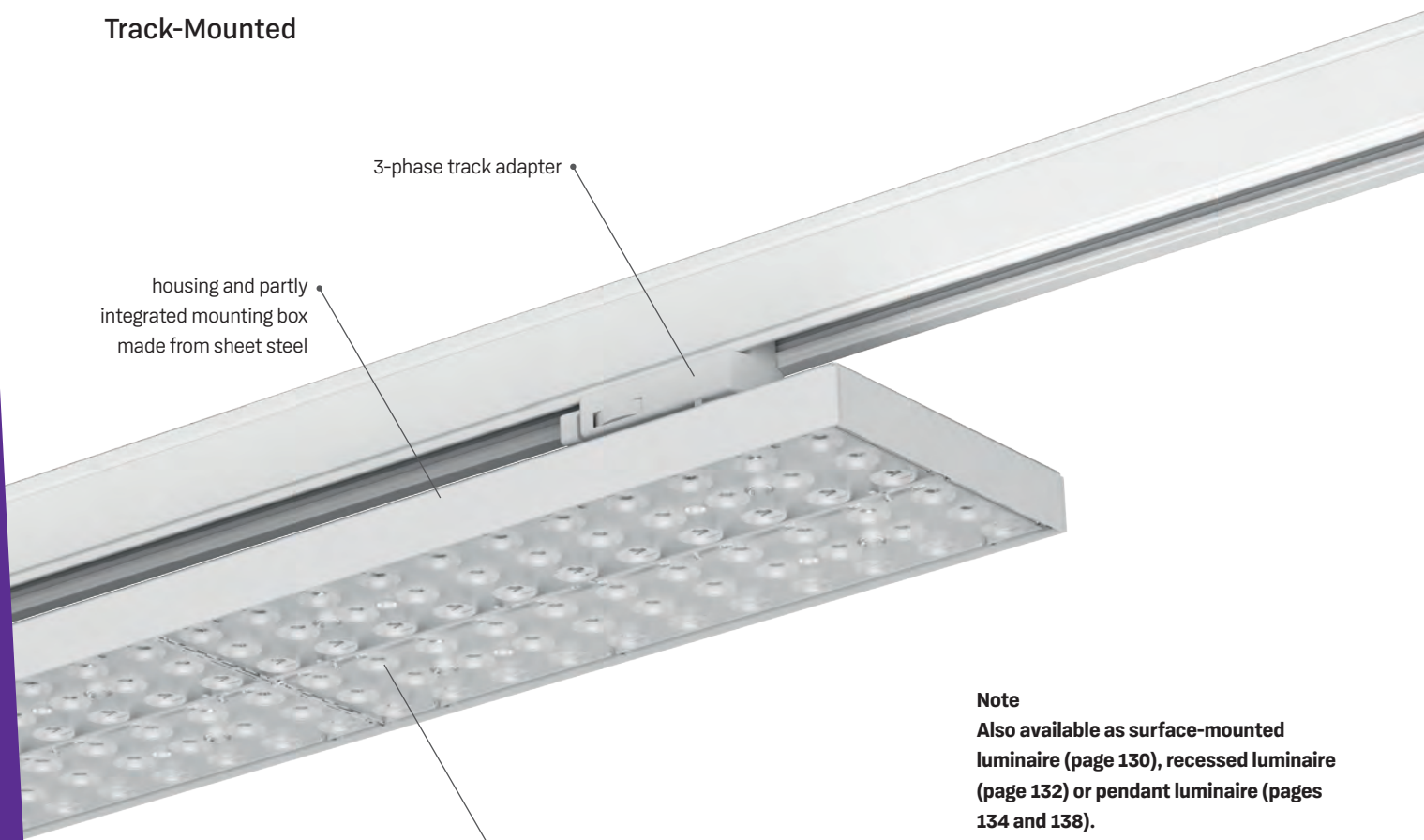

**Note**

Also available as surface-mounted luminaire (page 130), recessed luminaire (page 132) or pendant luminaire (pages 134 and 138).

1-row

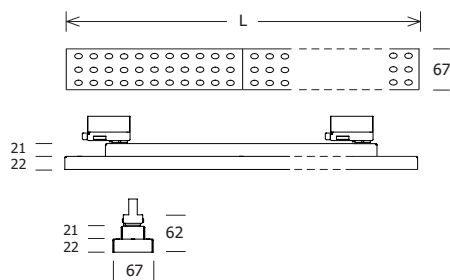

2-row

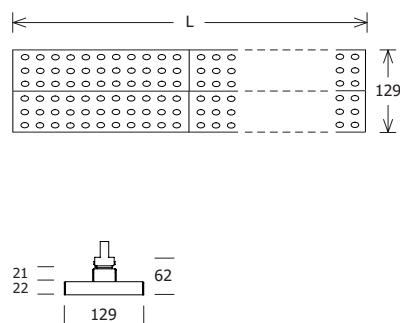

3-row

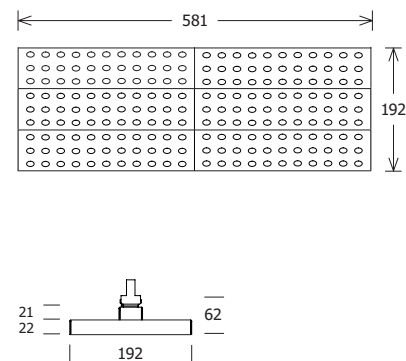

**Standard options**

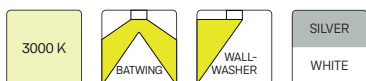

**Special options**





PLANA Küchenland, Pforzheim, GER · Photo: Juergen Pollak · Photographie & Film

## Range selection



| Article name      | Feature                       | L x B [mm] | CCT [K] | System power [W] | Luminous flux [lm] | Weight [kg] | EEC |
|-------------------|-------------------------------|------------|---------|------------------|--------------------|-------------|-----|
| LUZ06-T 12.007.40 | 1-row/2-length, power stage 1 | 581 x 67   | 4000    | 12               | 1650               | 1.71        | A++ |
| LUZ06-T 12.013.40 | 1-row/2-length, power stage 2 | 581 x 67   | 4000    | 24               | 3290               | 1.71        | A++ |
| LUZ06-T 13.007.40 | 1-row/3-length, power stage 1 | 867 x 67   | 4000    | 18               | 2470               | 2.34        | A++ |
| LUZ06-T 13.013.40 | 1-row/3-length, power stage 2 | 867 x 67   | 4000    | 36               | 4940               | 2.34        | A++ |
| LUZ06-T 14.007.40 | 1-row/4-length, power stage 1 | 1153 x 67  | 4000    | 24               | 3290               | 2.66        | A++ |
| LUZ06-T 14.013.40 | 1-row/4-length, power stage 2 | 1153 x 67  | 4000    | 48               | 6580               | 2.66        | A++ |
| LUZ06-T 15.007.40 | 1-row/5-length, power stage 1 | 1439 x 67  | 4000    | 30               | 4110               | 3.16        | A++ |
| LUZ06-T 15.013.40 | 1-row/5-length, power stage 2 | 1439 x 67  | 4000    | 60               | 8220               | 3.16        | A++ |
| LUZ06-T 22.007.40 | 2-row/2-length, power stage 1 | 581 x 129  | 4000    | 24               | 3290               | 2.46        | A++ |
| LUZ06-T 22.013.40 | 2-row/2-length, power stage 2 | 581 x 129  | 4000    | 48               | 6580               | 2.46        | A++ |
| LUZ06-T 23.007.40 | 2-row/3-length, power stage 1 | 867 x 129  | 4000    | 36               | 4940               | 3.26        | A++ |
| LUZ06-T 23.013.40 | 2-row/3-length, power stage 2 | 867 x 129  | 4000    | 72               | 9870               | 3.26        | A++ |
| LUZ06-T 32.007.40 | 3-row/2-length, power stage 1 | 581 x 192  | 4000    | 36               | 4940               | 3.26        | A++ |
| LUZ06-T 32.013.40 | 3-row/2-length, power stage 2 | 581 x 192  | 4000    | 72               | 9870               | 3.26        | A++ |

Further product informations you will find under [www.lts-light.eu/2431](http://www.lts-light.eu/2431)



# LUZ

## Track-Mounted Pendant

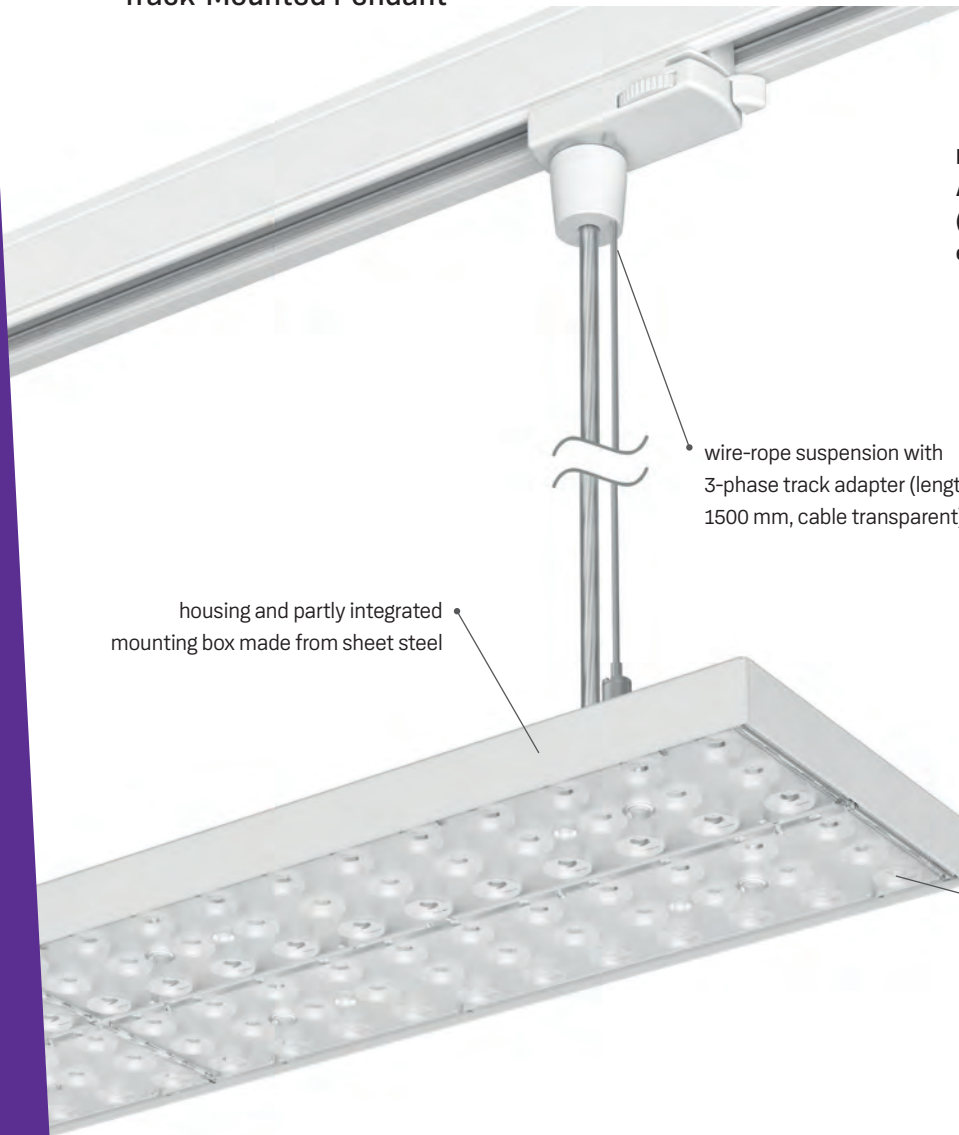

**Note**

Also available as surface-mounted luminaire (pages 130 and 136), recessed luminaire (page 132) or pendant luminaire (page 134).

housing and partly integrated mounting box made from sheet steel

wire-rope suspension with 3-phase track adapter (length: 1500 mm, cable transparent)

lense optics made from PMMA plastic (beam angle 60°, batwing or asymmetric)

1-row

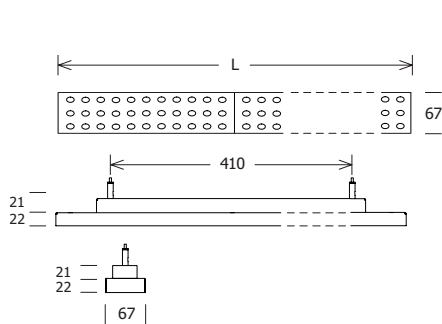

2-row

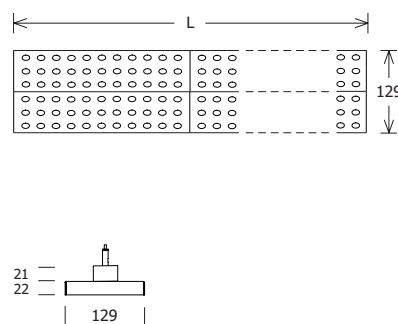

3-row

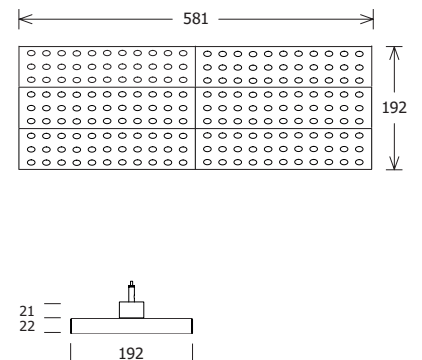

**Standard options**

|  |  |  |  |
|--|--|--|--|
|  |  |  |  |
|  |  |  |  |

**Special options**

|  |  |  |  |  |
|--|--|--|--|--|
|  |  |  |  |  |
|  |  |  |  |  |



VR-Bank, Würzburg, GER

## Range selection



| Article name      | Feature                       | L x B [mm] | CCT [K] | System power [W] | Luminous flux [lm] | Weight [kg] | EEC |
|-------------------|-------------------------------|------------|---------|------------------|--------------------|-------------|-----|
| LUZ06-P 12.007.40 | 1-row/2-length, power stage 1 | 581 x 67   | 4000    | 12               | 1650               | 1.76        | A++ |
| LUZ06-P 12.013.40 | 1-row/2-length, power stage 2 | 581 x 67   | 4000    | 24               | 3290               | 1.76        | A++ |
| LUZ06-P 13.007.40 | 1-row/3-length, power stage 1 | 867 x 67   | 4000    | 18               | 2470               | 2.26        | A++ |
| LUZ06-P 13.013.40 | 1-row/3-length, power stage 2 | 867 x 67   | 4000    | 36               | 4940               | 2.26        | A++ |
| LUZ06-P 14.007.40 | 1-row/4-length, power stage 1 | 1153 x 67  | 4000    | 24               | 3290               | 2.80        | A++ |
| LUZ06-P 14.013.40 | 1-row/4-length, power stage 2 | 1153 x 67  | 4000    | 48               | 6580               | 2.80        | A++ |
| LUZ06-P 15.007.40 | 1-row/5-length, power stage 1 | 1439 x 67  | 4000    | 30               | 4110               | 3.26        | A++ |
| LUZ06-P 15.013.40 | 1-row/5-length, power stage 2 | 1439 x 67  | 4000    | 60               | 8220               | 3.26        | A++ |
| LUZ06-P 22.007.40 | 2-row/2-length, power stage 1 | 581 x 129  | 4000    | 24               | 3290               | 2.58        | A++ |
| LUZ06-P 22.013.40 | 2-row/2-length, power stage 2 | 581 x 129  | 4000    | 48               | 6580               | 2.58        | A++ |
| LUZ06-P 23.007.40 | 2-row/3-length, power stage 1 | 867 x 129  | 4000    | 36               | 4940               | 3.46        | A++ |
| LUZ06-P 23.013.40 | 2-row/3-length, power stage 2 | 867 x 129  | 4000    | 72               | 9870               | 3.46        | A++ |
| LUZ06-P 32.007.40 | 3-row/2-length, power stage 1 | 581 x 192  | 4000    | 36               | 4940               | 3.36        | A++ |
| LUZ06-P 32.013.40 | 3-row/2-length, power stage 2 | 581 x 192  | 4000    | 72               | 9870               | 3.36        | A++ |

Further product informations you will find under [www.lts-light.eu/2644](http://www.lts-light.eu/2644)

# Monoline 070

Surface-Mounted & Pendant

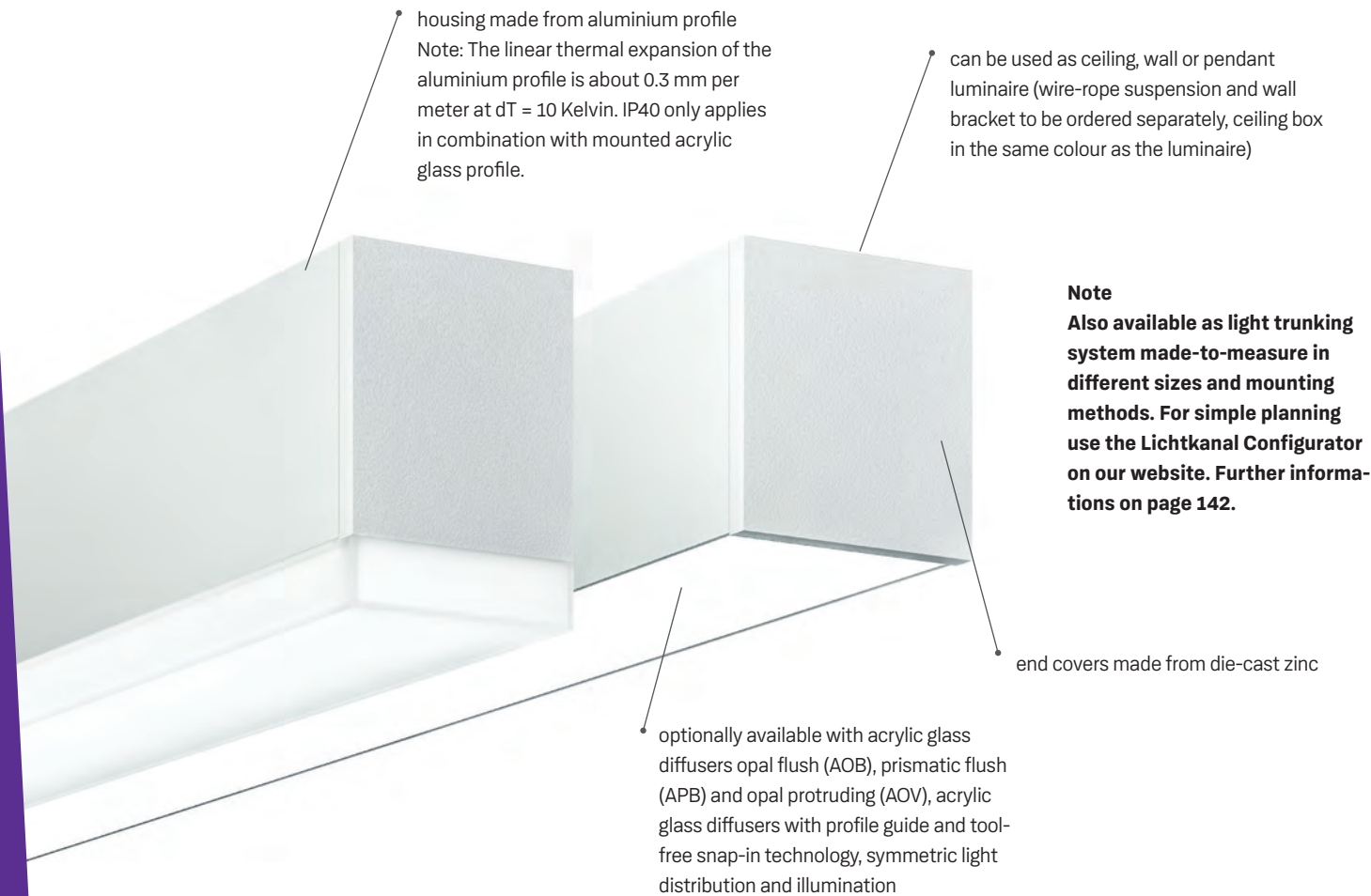

**Note**  
 Also available as light trunking system made-to-measure in different sizes and mounting methods. For simple planning use the Lichtkanal Configurator on our website. Further information on page 142.

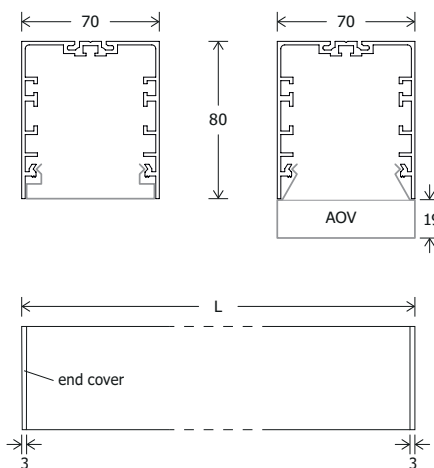

**Standard options**

|        |      |                                      |
|--------|------|--------------------------------------|
| 3000 K | DALI | BLACK<br>SILVER<br>ANODISED<br>WHITE |
|--------|------|--------------------------------------|

**Special options**

|        |                 |     |      |     |
|--------|-----------------|-----|------|-----|
| 2700 K | CRI 90<br>SDCM3 | TWL | TWPI | RAL |
|--------|-----------------|-----|------|-----|



## Range selection



| Article name         | Feature                                  | Length [mm] | CCT [K] | System power [W] | Luminous flux [lm] | Weight [kg] | EEC |
|----------------------|--|-------------|---------|------------------|--------------------|-------------|-----|
| ML-A 070.0740.08 AOB | diffuser opal flush / power stage 1      | 855         | 4000    | 12               | 1110               | 2.80        | A+  |
| ML-A 070.0740.08 APB | diffuser prismatic flush / power stage 1 | 855         | 4000    | 12               | 1040               | 2.80        | A+  |
| ML-A 070.0740.08 AOV | diffuser opal protruding / power stage 1 | 855         | 4000    | 12               | 1250               | 3.10        | A+  |
| ML-A 070.0740.11 AOB | diffuser opal flush / power stage 1      | 1136        | 4000    | 14               | 1380               | 3.60        | A+  |
| ML-A 070.0740.11 APB | diffuser prismatic flush / power stage 1 | 1136        | 4000    | 14               | 1300               | 3.60        | A+  |
| ML-A 070.0740.11 AOV | diffuser opal protruding / power stage 1 | 1136        | 4000    | 14               | 1560               | 4.00        | A+  |
| ML-A 070.0740.14 AOB | diffuser opal flush / power stage 1      | 1416        | 4000    | 17               | 1780               | 4.30        | A++ |
| ML-A 070.0740.14 APB | diffuser prismatic flush / power stage 1 | 1416        | 4000    | 17               | 1680               | 4.30        | A+  |
| ML-A 070.0740.14 AOV | diffuser opal protruding / power stage 1 | 1416        | 4000    | 17               | 2000               | 4.80        | A+  |
| ML-A 070.1040.08 AOB | diffuser opal flush / power stage 2      | 855         | 4000    | 15               | 1510               | 2.80        | A+  |
| ML-A 070.1040.08 APB | diffuser prismatic flush / power stage 2 | 855         | 4000    | 15               | 1420               | 2.80        | A+  |
| ML-A 070.1040.08 AOV | diffuser opal protruding / power stage 2 | 855         | 4000    | 15               | 1710               | 3.10        | A++ |
| ML-A 070.1040.11 AOB | diffuser opal flush / power stage 2      | 1136        | 4000    | 20               | 2010               | 3.60        | A+  |
| ML-A 070.1040.11 APB | diffuser prismatic flush / power stage 2 | 1136        | 4000    | 20               | 1890               | 3.60        | A+  |
| ML-A 070.1040.11 AOV | diffuser opal protruding / power stage 2 | 1136        | 4000    | 20               | 2270               | 4.00        | A++ |
| ML-A 070.1040.14 AOB | diffuser opal flush / power stage 2      | 1416        | 4000    | 25               | 2520               | 4.30        | A+  |
| ML-A 070.1040.14 APB | diffuser prismatic flush / power stage 2 | 1416        | 4000    | 25               | 2370               | 4.30        | A+  |
| ML-A 070.1040.14 AOV | diffuser opal protruding / power stage 2 | 1416        | 4000    | 25               | 2840               | 4.80        | A++ |
| ML-A 070.1140.08 AOB | diffuser opal flush / power stage 3      | 855         | 4000    | 36               | 3280               | 2.80        | A+  |
| ML-A 070.1140.08 APB | diffuser prismatic flush / power stage 3 | 855         | 4000    | 36               | 3080               | 2.80        | A+  |
| ML-A 070.1140.08 AOV | diffuser opal protruding / power stage 3 | 855         | 4000    | 36               | 3500               | 3.10        | A+  |
| ML-A 070.1140.11 AOB | diffuser opal flush / power stage 3      | 1136        | 4000    | 48               | 4380               | 3.60        | A+  |
| ML-A 070.1140.11 APB | diffuser prismatic flush / power stage 3 | 1136        | 4000    | 48               | 4120               | 3.60        | A+  |
| ML-A 070.1140.11 AOV | diffuser opal protruding / power stage 3 | 1136        | 4000    | 48               | 4650               | 4.00        | A+  |
| ML-A 070.1140.14 AOB | diffuser opal flush / power stage 3      | 1416        | 4000    | 60               | 5540               | 4.30        | A+  |
| ML-A 070.1140.14 APB | diffuser prismatic flush / power stage 3 | 1416        | 4000    | 60               | 5210               | 4.30        | A+  |
| ML-A 070.1140.14 AOV | diffuser opal protruding / power stage 3 | 1416        | 4000    | 60               | 6010               | 4.80        | A+  |

## Accessories

| Article name    | Description   |
|-----------------|---|
| LK-Z 070.103.03 | wire-rope suspension with feeder and transparent connecting cable (length: 3000 mm) |
| LK-Z 070.103.05 | wire-rope suspension with feeder and transparent connecting cable (length: 5000 mm) |
| LK-Z 070.104.03 | wire-rope suspension (length: 3000 mm)  |
| LK-Z 070.104.05 | wire-rope suspension (length: 5000 mm)  |
| LK-Z 070.114    | wall bracket (1 piece)  |

Further product informations you will find under [www.lts-light.eu/2425](http://www.lts-light.eu/2425)

# LIGHT ALL ALONG THE LINE

## THE LICHTKANAL FAMILY



Lichtkanal is our architectural light line with individuality taking centre stage. It fits subtly into building structures or deliberately stages them according to the chosen arrangement. Lichtkanal is available in four different basic types. It can be recessed, surface-mounted or suspended. With Lichtkanal 060 there is a system available that enables direct-indirect illumination.

The lighting inserts can be chosen as needed. They differ in terms of their performance and colour temperature. All lighting tasks can be tackled with thoughtfully designed acrylic glass diffusers, films or the patented nanoOptix microstructure film. For example, the innovative nanoOptix film is suitable for longer light lengths with no impact from visible edges – an aesthetic advantage that should not be underestimated.

Lichtkanal is always customised and produced to order in terms of its length and shape. This means that it perfectly adapts to any given structural conditions.



Download the new Lichtkanal brochure now:  
[www.lts-light.com/downloads/brochures](http://www.lts-light.com/downloads/brochures)

# STEP BY STEP

## THE LICHTKANAL CONFIGURATOR

The configurator helps in determining the right Lichtkanal. Key requirements, such as mounting type, colour temperature, colour or controls are obtained and summarised in a product proposal. It enables orthogonal special variants to be created. Each design also comes with the data sheets of the items used and a cost estimate. The configurator helps in determining the right Lichtkanal. Key requirements, such as mounting type, colour temperature, colour or controls are obtained and summarised in a product proposal. It enables orthogonal special variants to be created. Each design also comes with the data sheets of the items used and a cost estimate.



- System 01
- Mounting type 02
- Cover 03
- Colour 04
- DALI 05
- Colour temperature 06
- System power & luminous flux 07
- Shape 08
- Outer length 09



Design your customised Lichtkanal now:  
[app.lts-light.com/lichtkanal-en](http://app.lts-light.com/lichtkanal-en)



# Piano

## Pendant

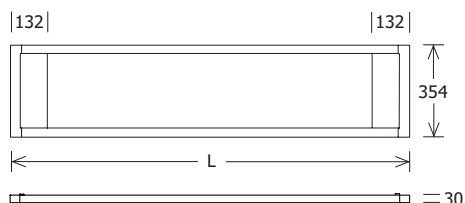

### Standard options



### Special options





UNESCO-Weiterbe Fagus-Werk, Alfeld, GER · Planning: Elektro Beckmann · Photo: Sven Otte Fotografie



## Range selection

| Article name           | Feature           | Length [mm] | CCT [K] | System power [W] | Luminous flux [lm] | UGR  | Weight [kg] | EEC |
|------------------------|-------------------|-------------|---------|------------------|--------------------|------|-------------|-----|
| PIANO-P 140.0840/DALI  | dimnable DALI     | 1400        | 4000    | 80               | 8380               | 19.0 | 7.29        | A++ |
| PIANO-P 140.0840/SENSO | automatic sensors | 1400        | 4000    | 80               | 8380               | 19.0 | 7.61        | A++ |
| PIANO-P 140.0840/TROOP | trooping          | 1400        | 4000    | 80               | 8380               | 19.0 | 7.61        | A++ |
| PIANO-P 195.1040/DALI  | dimnable DALI     | 1950        | 4000    | 120              | 12570              | 19.0 | 10.11       | A++ |
| PIANO-P 195.1040/SENSO | automatic sensors | 1950        | 4000    | 120              | 12570              | 19.0 | 10.33       | A++ |
| PIANO-P 195.1040/TROOP | trooping          | 1950        | 4000    | 120              | 12570              | 19.0 | 10.16       | A++ |
| PIANO-P 260.1640/DALI  | dimnable DALI     | 2573        | 4000    | 160              | 16760              | 18.9 | 13.83       | A++ |
| PIANO-P 260.1640/SENSO | automatic sensors | 2573        | 4000    | 160              | 16760              | 18.9 | 12.99       | A++ |
| PIANO-P 260.1640/TROOP | trooping          | 2573        | 4000    | 160              | 16760              | 18.9 | 13.04       | A++ |

## Accessories

| Article name    | Description   |
|-----------------|---|
| PIANO-Z 090.102 | connection kit for row installation of PIANO-P luminaires (only possible with DALI-Version version)   |
| PIANO-Z 090.103 | connecting cable for row installation of PIANO-P luminaires (only possible with DALI-Version version) |

Further product informations you will find under [www.lts-light.eu/2627](http://www.lts-light.eu/2627)

# PL 20

Surface-Mounted & Pendant



**Note**  
Also available as square version  
PL 50 (page 158).

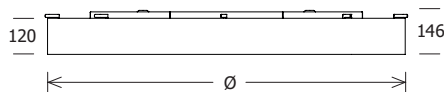

**Standard options**



**Special options**







Microsoft, London, GB · Planung: TP Bennet LLP · Photo: TP Bennet LLP

## Range selection



| Article name        | Ø [mm] | CCT [K] | System power [W] | Luminous flux [lm] | Fixing                        | Weight [kg] | EEC |
|---------------------|--------|---------|------------------|--------------------|-------------------------------|-------------|-----|
| PLL 20.700.40/DALI  | 700    | 4000    | 67               | 5690               | L 68/1500 DIM / L 68/3000 DIM | 12.50       | A+  |
| PLL 20.900.40/DALI  | 900    | 4000    | 97               | 7980               | L 68/1500 DIM / L 68/3000 DIM | 19.00       | A+  |
| PLL 20.1180.40/DALI | 1180   | 4000    | 156              | 13820              | L 68/1500 DIM / L 68/3000 DIM | 30.00       | A+  |
| PLL 20.1500.40/DALI | 1500   | 4000    | 265              | 22270              | L 84/3000 DIM                 | 48.00       | A+  |
| PLL 20.1800.40/DALI | 1800   | 4000    | 390              | 34090              | L 84/3000 DIM                 | 71.00       | A+  |

## Accessories

| Article name  | Description   |
|---------------|---|
| L 68/1500 DIM | wire-rope suspension 4-fold (length: 1500 mm, 5-core cable) |
| L 68/3000 DIM | wire-rope suspension 4-fold (length: 3000 mm, 5-core cable) |
| L 84/3000 DIM | wire-rope suspension 8-fold (length: 3000 mm, 5-core cable) |

Further product informations you will find under [www.lts-light.eu/2604](http://www.lts-light.eu/2604)

# PL 22

Surface-Mounted & Pendant



**Note**

Also available as recessed luminaires PL 25 and PL 27 (pages 150 and 154), wall luminaire PL 23 (page 182) and direct-indirect versions PL 26 and PL 28 (pages 152 and 156).

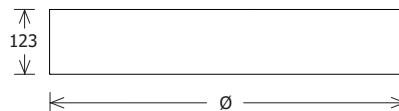

**Standard options**



**Special options**





Frühlings-Apothek, Bad Aibling, GER · Planning: Beckert & Soanca-Pollak · Photo: Andreas Huber Fotografie

## Range selection



| Article name          | Ø [mm] | Feature            | CCT [K] | System power [W] | Luminous flux [lm] | Fixing                        | Weight [kg] | EEC |
|-----------------------|--------|--------------------|---------|------------------|--------------------|-------------------------------|-------------|-----|
| PLL 22.385.40.1/DALI  | 385    | diffuser opal      | 4000    | 22               | 1890               | L 71/1500 DIM / L 71/3000 DIM | 3.67        | A+  |
| PLL 22.385.40.2/DALI  | 385    | diffuser prismatic | 4000    | 22               | 1370               | L 71/1500 DIM / L 71/3000 DIM | 3.67        | A   |
| PLL 22.475.40.1/DALI  | 475    | diffuser opal      | 4000    | 39               | 3570               | L 71/1500 DIM / L 71/3000 DIM | 4.73        | A+  |
| PLL 22.475.40.2/DALI  | 475    | diffuser prismatic | 4000    | 39               | 2580               | L 71/1500 DIM / L 71/3000 DIM | 4.73        | A   |
| PLL 22.675.40.1/DALI  | 675    | diffuser opal      | 4000    | 75               | 8030               | L 71/1500 DIM / L 71/3000 DIM | 9.32        | A++ |
| PLL 22.675.40.2/DALI  | 675    | diffuser prismatic | 4000    | 75               | 5790               | L 71/1500 DIM / L 71/3000 DIM | 9.32        | A+  |
| PLL 22.1000.40.1/DALI | 1000   | diffuser opal      | 4000    | 164              | 17640              | L 71/3000 DIM                 | 19.50       | A++ |
| PLL 22.1000.40.2/DALI | 1000   | diffuser prismatic | 4000    | 164              | 12710              | L 71/3000 DIM                 | 19.50       | A+  |

## Accessories

| Article name  | Description   |
|---------------|---|
| L 71/1500 DIM | wire-rope suspension 3-fold (length: 1500 mm, 5-core cable) |
| L 71/3000 DIM | wire-rope suspension 3-fold (length: 3000 mm, 5-core cable) |

Further product informations you will find under [www.lts-light.eu/2623](http://www.lts-light.eu/2623)



# PL 25

## Recessed Trimless

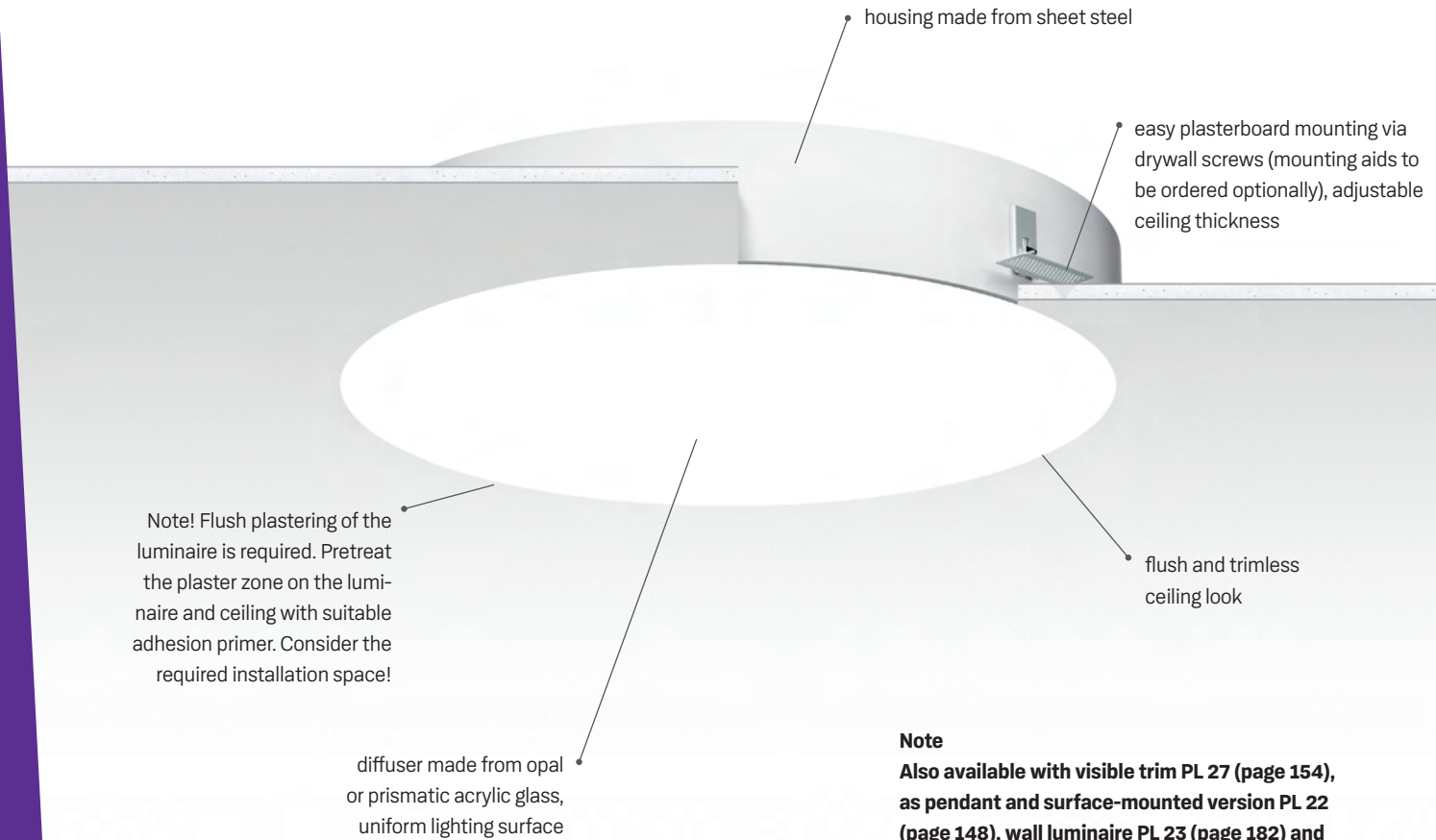

**Note**  
 Also available with visible trim PL 27 (page 154), as pendant and surface-mounted version PL 22 (page 148), wall luminaire PL 23 (page 182) and direct-indirect versions PL 26 and PL 28 (pages 152 and 156).

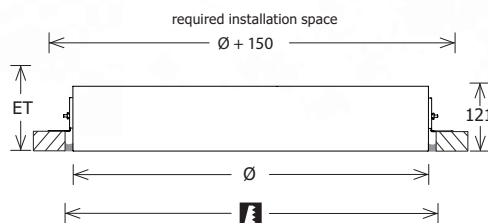

**Standard options**



**Special options**





Burnickl Ingenieure, Velburg, GER · Planning: Burnickl Ingenieure · Photo: Stefan Grasenhiller Kreativwerkraum

## Range selection



| Article name          | Ø [mm] | Feature            | CCT [K] | System power [W] | Luminous flux [lm] | Installation depth [mm] | Cut-out [mm] | Ceiling thickness [mm] | Weight [kg] | EEC |
|-----------------------|--------|--------------------|---------|------------------|--------------------|-------------------------|--------------|------------------------|-------------|-----|
| PLL 25.385.40.1/DALI  | 385    | diffuser opal      | 4000    | 22               | 1890               | 151                     | Ø 390        | 10 - 30                | 3.78        | A+  |
| PLL 25.385.40.2/DALI  | 385    | diffuser prismatic | 4000    | 22               | 1370               | 151                     | Ø 390        | 10 - 30                | 3.78        | A   |
| PLL 25.475.40.1/DALI  | 475    | diffuser opal      | 4000    | 39               | 3570               | 151                     | Ø 480        | 10 - 30                | 5.24        | A+  |
| PLL 25.475.40.2/DALI  | 475    | diffuser prismatic | 4000    | 39               | 2580               | 151                     | Ø 480        | 10 - 30                | 5.24        | A   |
| PLL 25.675.40.1/DALI  | 675    | diffuser opal      | 4000    | 75               | 8030               | 151                     | Ø 680        | 10 - 30                | 9.26        | A++ |
| PLL 25.675.40.2/DALI  | 675    | diffuser prismatic | 4000    | 75               | 5790               | 151                     | Ø 680        | 10 - 30                | 9.26        | A+  |
| PLL 25.1000.40.1/DALI | 1000   | diffuser opal      | 4000    | 164              | 17640              | 151                     | Ø 1005       | 10 - 30                | 19.00       | A++ |
| PLL 25.1000.40.2/DALI | 1000   | diffuser prismatic | 4000    | 164              | 12710              | 151                     | Ø 1005       | 10 - 30                | 19.00       | A+  |

## Accessories

| Article name | Description                         |
|--------------|-------------------------------------|
| ZBMH 1000    | mounting aids PL 25 for D = 1000 mm |
| ZBMH 385     | mounting aids PL 25 for D = 385 mm  |
| ZBMH 475     | mounting aids PL 25 for D = 475 mm  |
| ZBMH 675     | mounting aids PL 25 for D = 675 mm  |

Further product informations you will find under [www.lts-light.eu/2158](http://www.lts-light.eu/2158)

# PL 26 Direct-Indirect

Surface-Mounted



**Note**

Also available as surface-mounted/pendant luminaire PL 22 (page 148), recessed luminaires PL 25 and PL 27 (pages 150 and 154), wall luminaire PL 23 (page 182) and direct-indirect pendant version PL 28 (page 156).

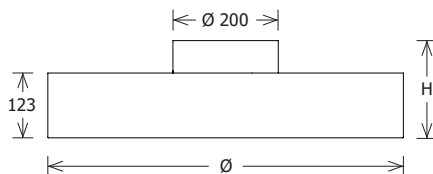

**Standard options**



**Special options**

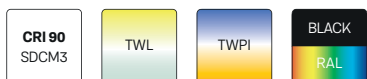





Federseeklinik, Bad Buchau, GER · Photo: Jean-Marc Delettre – Photography

## Range selection



| Article name          | Ø x H [mm] | Feature            | CCT [K] | System power [W] | Luminous flux [lm] | Light component indirect [%] | Weight [kg] | EEC |
|-----------------------|------------|--------------------|---------|------------------|--------------------|------------------------------|-------------|-----|
| PLL 26.385.40.1/DALI  | 385 x 187  | diffuser opal      | 4000    | 36               | 3850               | 33                           | 4.74        | A++ |
| PLL 26.385.40.2/DALI  | 385 x 187  | diffuser prismatic | 4000    | 36               | 3220               | 42                           | 4.74        | A+  |
| PLL 26.475.40.1/DALI  | 475 x 185  | diffuser opal      | 4000    | 49               | 5500               | 22                           | 6.12        | A++ |
| PLL 26.475.40.2/DALI  | 475 x 185  | diffuser prismatic | 4000    | 49               | 4200               | 29                           | 6.12        | A+  |
| PLL 26.675.40.1/DALI  | 675 x 185  | diffuser opal      | 4000    | 97               | 11830              | 21                           | 10.40       | A++ |
| PLL 26.675.40.2/DALI  | 675 x 185  | diffuser prismatic | 4000    | 97               | 9300               | 27                           | 10.40       | A+  |
| PLL 26.1000.40.1/DALI | 1000 x 185 | diffuser opal      | 4000    | 209              | 26090              | 28                           | 22.50       | A++ |
| PLL 26.1000.40.2/DALI | 1000 x 185 | diffuser prismatic | 4000    | 209              | 18330              | 26                           | 22.50       | A+  |

Further product informations you will find under [www.lts-light.eu/2413](http://www.lts-light.eu/2413)

# PL 27

Recessed

housing made from sheet steel

tool-free ceiling mounting via quick-action clamping springs, adjustable ceiling thickness, Note! Consider the required installation space!

diffuser made from opal or prismatic acrylic glass, uniform lighting surface

flush ceiling look by filigree trim

**Note**

Also available as version with trimless ceiling look PL 25 (page 150), as pendant and surface-mounted version PL 22 (page 148), wall luminaire PL 23 (page 182) and direct-indirect versions PL 26 and PL 28 (pages 152 and 156).

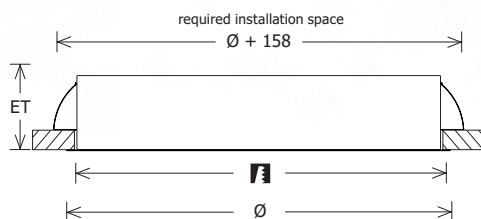

Standard options



Special options





DEUTZ-FAHR Arena, Lauingen, GER · Planning: archiNetwork · Photo: Foto Hammer

## Range selection



| Article name          | Ø [mm] | Feature            | CCT [K] | System power [W] | Luminous flux [lm] | Installation depth [mm] | Cut-out [mm] | Ceiling thickness [mm] | Weight [kg] | EEC |
|-----------------------|--------|--------------------|---------|------------------|--------------------|-------------------------|--------------|------------------------|-------------|-----|
| PLL 27.410.40.1/DALI  | 411    | diffuser opal      | 4000    | 22               | 1890               | 145                     | Ø 390        | 10 - 30                | 3.75        | A+  |
| PLL 27.410.40.2/DALI  | 411    | diffuser prismatic | 4000    | 22               | 1370               | 145                     | Ø 390        | 10 - 30                | 3.75        | A   |
| PLL 27.500.40.1/DALI  | 501    | diffuser opal      | 4000    | 39               | 3570               | 145                     | Ø 480        | 10 - 30                | 5.19        | A+  |
| PLL 27.500.40.2/DALI  | 501    | diffuser prismatic | 4000    | 39               | 2580               | 145                     | Ø 480        | 10 - 30                | 5.19        | A   |
| PLL 27.700.40.1/DALI  | 701    | diffuser opal      | 4000    | 75               | 8030               | 141                     | Ø 680        | 10 - 30                | 9.60        | A++ |
| PLL 27.700.40.2/DALI  | 701    | diffuser prismatic | 4000    | 75               | 5790               | 141                     | Ø 680        | 10 - 30                | 9.60        | A+  |
| PLL 27.1025.40.1/DALI | 1026   | diffuser opal      | 4000    | 164              | 17640              | 145                     | Ø 1005       | 10 - 30                | 20.00       | A++ |
| PLL 27.1025.40.2/DALI | 1026   | diffuser prismatic | 4000    | 164              | 12710              | 145                     | Ø 1005       | 10 - 30                | 20.00       | A+  |

Further product informations you will find under [www.lts-light.eu/2159](http://www.lts-light.eu/2159)



# PL 28 Direct-Indirect

## Pendant



**Note**  
Also available as surface-mounted/pendant luminaire PL 22 (page 148), recessed luminaires PL 25 and PL 27 (pages 150 and 154), wall luminaire PL 23 (page 182) and direct-indirect ceiling version PL 26 (page 152).

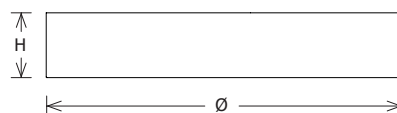

### Standard options



### Special options





Federseelklinik, Bad Buchau, GER · Photo: Jean-Marc Delettre – Photography

## Range selection



| Article name          | Ø x H [mm] | Feature            | CCT [K] | System power [W] | Luminous flux [lm] | Light component indirect [%] | Fixing                        | Weight [kg] | EEC |
|-----------------------|------------|--------------------|---------|------------------|--------------------|------------------------------|-------------------------------|-------------|-----|
| PLL 28.385.40.1/DALI  | 385 x 123  | diffuser opal      | 4000    | 36               | 3850               | 33                           | L 73/1500 DIM / L 73/3000 DIM | 4.02        | A++ |
| PLL 28.385.40.2/DALI  | 385 x 123  | diffuser prismatic | 4000    | 36               | 3220               | 42                           | L 73/1500 DIM / L 73/3000 DIM | 4.02        | A+  |
| PLL 28.475.40.1/DALI  | 475 x 123  | diffuser opal      | 4000    | 49               | 5500               | 22                           | L 73/1500 DIM / L 73/3000 DIM | 5.30        | A++ |
| PLL 28.475.40.2/DALI  | 475 x 123  | diffuser prismatic | 4000    | 49               | 4200               | 29                           | L 73/1500 DIM / L 73/3000 DIM | 5.30        | A+  |
| PLL 28.675.40.1/DALI  | 675 x 123  | diffuser opal      | 4000    | 97               | 11830              | 21                           | L 74/1500 DIM / L 74/3000 DIM | 10.00       | A++ |
| PLL 28.675.40.2/DALI  | 675 x 123  | diffuser prismatic | 4000    | 97               | 9300               | 27                           | L 74/1500 DIM / L 74/3000 DIM | 10.00       | A+  |
| PLL 28.1000.40.1/DALI | 1000 x 127 | diffuser opal      | 4000    | 209              | 26090              | 28                           | L 75/1500 DIM / L 75/3000 DIM | 21.00       | A++ |
| PLL 28.1000.40.2/DALI | 1000 x 127 | diffuser prismatic | 4000    | 209              | 18330              | 26                           | L 75/1500 DIM / L 75/3000 DIM | 21.00       | A+  |

## Accessories

| Article name  | Description   |
|---------------|---|
| L 73/1500 DIM | wire-rope suspension 3-fold (length: 1500 mm, 5-core cable) |
| L 73/3000 DIM | wire-rope suspension 3-fold (length: 3000 mm, 5-core cable) |
| L 74/1500 DIM | wire-rope suspension 3-fold (length: 1500 mm, 5-core cable) |
| L 74/3000 DIM | wire-rope suspension 3-fold (length: 3000 mm, 5-core cable) |
| L 75/1500 DIM | wire-rope suspension 4-fold (length: 1500 mm, 5-core cable) |
| L 75/3000 DIM | wire-rope suspension 4-fold (length: 3000 mm, 5-core cable) |

Further product informations you will find under [www.lts-light.eu/2624](http://www.lts-light.eu/2624)

# PL 50

Surface-Mounted & Pendant

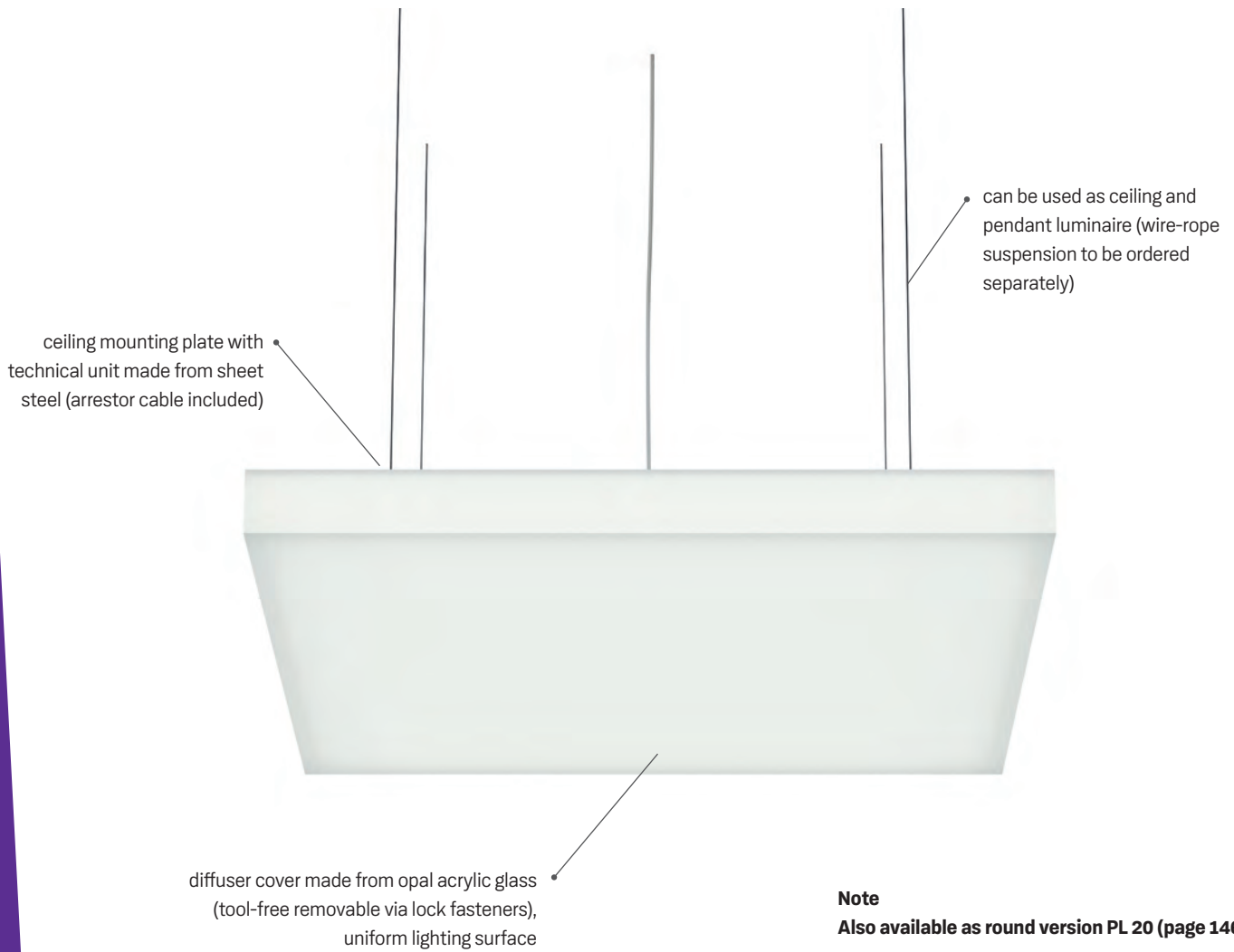

**Note**  
Also available as round version PL 20 (page 146).



**Standard options**



**Special options**







Burnickl Ingenieure, Velburg, GER · Planning: Burnickl Ingenieure · Photo: Stefan Grasenhiller Kreativwerkraum

## Range selection



| Article name          | L x B [mm]  | CCT [K] | System power [W] | Luminous flux [lm] | Fixing        | Weight [kg] | EEC |
|-----------------------|-------------|---------|------------------|--------------------|---------------|-------------|-----|
| PLL 50.625.40.1/DALI  | 625 x 625   | 4000    | 52               | 4010               | L 72/3000 DIM | 11.16       | A+  |
| PLL 50.900.40.1/DALI  | 900 x 900   | 4000    | 117              | 9230               | L 72/3000 DIM | 24.00       | A+  |
| PLL 50.1200.40.1/DALI | 1200 x 1200 | 4000    | 203              | 15470              | L 72/3000 DIM | 42.00       | A+  |
| PLL 50.1500.40.1/DALI | 1500 x 1500 | 4000    | 320              | 24100              | L 72/3000 DIM | 62.00       | A+  |

## Accessories

| Article name  | Description   |
|---------------|---|
| L 72/3000 DIM | wire-rope suspension 4-fold (length: 3000 mm, 5-core cable) |

Further product informations you will find under [www.its-light.eu/2625](http://www.its-light.eu/2625)

# PL 52

Surface-Mounted & Pendant

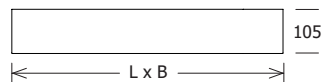
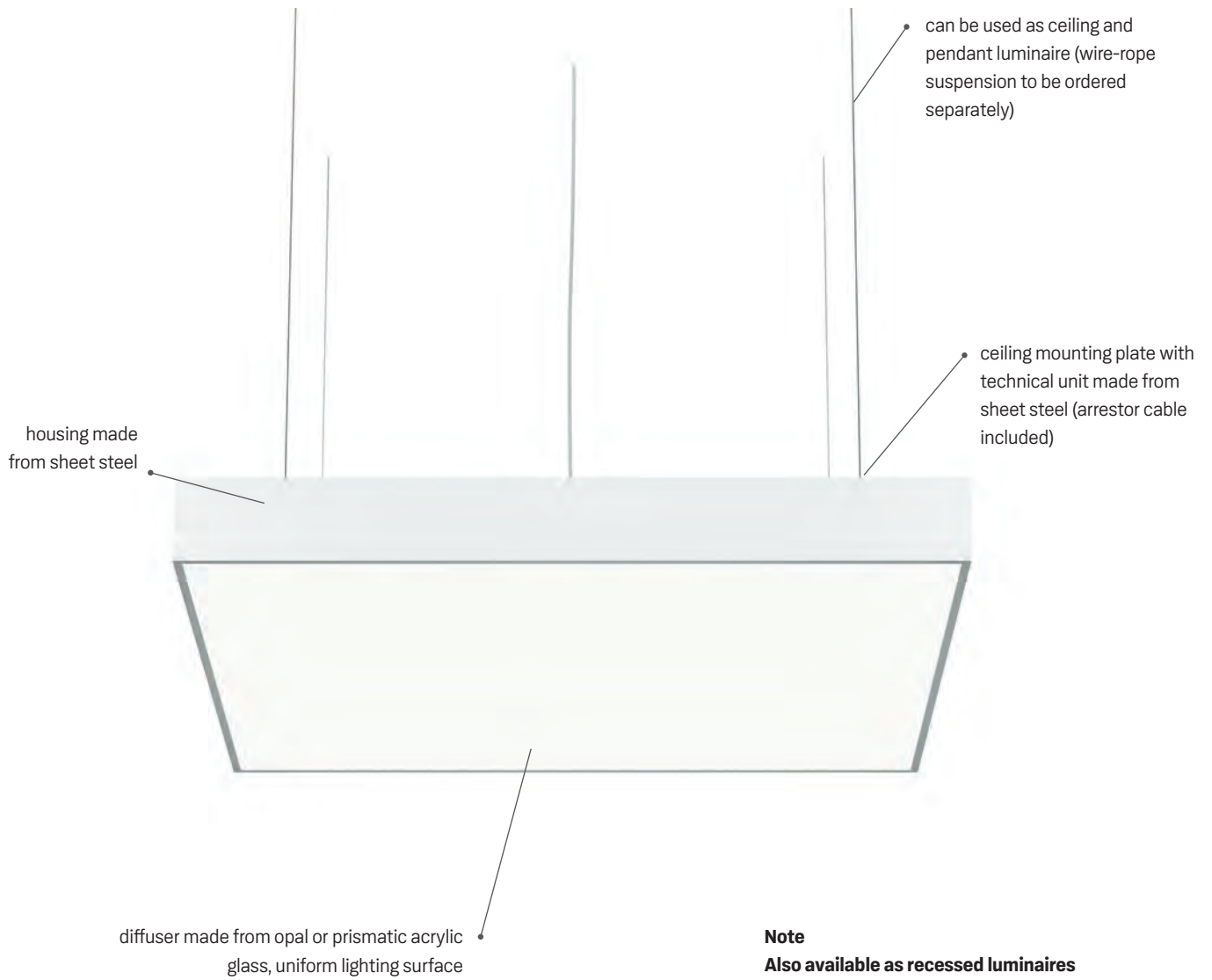

Standard options



Special options







RavensBuch, Tettngang, GER · Planning: Planungsbüro Gaiser

## Range selection



| Article name          | L x B [mm]  | Feature            | CCT [K] | System power [W] | Luminous flux [lm] | Fixing                        | Weight [kg] | EEC |
|-----------------------|-------------|--------------------|---------|------------------|--------------------|-------------------------------|-------------|-----|
| PLL 52.600.40.1/DALI  | 600 x 600   | diffuser opal      | 4000    | 53               | 5090               | L 72/1500 DIM / L 72/3000 DIM | 10.60       | A+  |
| PLL 52.600.40.2/DALI  | 600 x 600   | diffuser prismatic | 4000    | 53               | 3840               | L 72/1500 DIM / L 72/3000 DIM | 10.60       | A   |
| PLL 52.900.40.1/DALI  | 900 x 900   | diffuser opal      | 4000    | 112              | 11150              | L 72/1500 DIM / L 72/3000 DIM | 23.70       | A+  |
| PLL 52.900.40.2/DALI  | 900 x 900   | diffuser prismatic | 4000    | 112              | 8930               | L 72/1500 DIM / L 72/3000 DIM | 23.70       | A+  |
| PLL 52.1200.40.1/DALI | 1200 x 1200 | diffuser opal      | 4000    | 197              | 21660              | L 72/3000 DIM                 | 30.00       | A++ |
| PLL 52.1200.40.2/DALI | 1200 x 1200 | diffuser prismatic | 4000    | 197              | 16760              | L 72/3000 DIM                 | 30.00       | A+  |

## Accessories

| Article name  | Description   |
|---------------|---|
| L 72/1500 DIM | wire-rope suspension 4-fold (length: 1500 mm, 5-core cable) |
| L 72/3000 DIM | wire-rope suspension 4-fold (length: 3000 mm, 5-core cable) |

Further product informations you will find under [www.its-light.eu/2626](http://www.its-light.eu/2626)



# PL 55

## Recessed Trimless

housing made from sheet steel

easy plasterboard mounting via drywall screws, adjustable ceiling thickness

Note! Flush plastering of the luminaire is required. Pretreat the plaster zone on the luminaire and ceiling with suitable adhesion primer. Consider the required installation space!

diffuser made from opal or prismatic acrylic glass, uniform lighting surface

flush and trimless ceiling look

**Note**

Also available with visible trim PL 57 (page 164) or as pendant and surface-mounted version PL 52 (page 160).

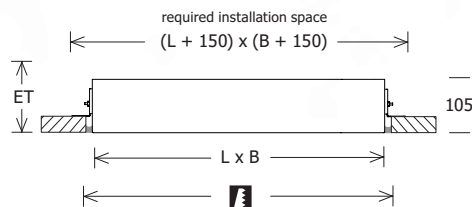

Standard options



Special options





Aston Martin, Stuttgart, GER · Photo: Enrique Salcedo Puerto

## Range selection



| Article name          | L x B [mm]  | Feature            | CCT [K] | System power [W] | Luminous flux [lm] | Installation depth [mm] | Cut-out [mm] | Ceiling thickness [mm] | Weight [kg] | EEC |
|-----------------------|-------------|--------------------|---------|------------------|--------------------|-------------------------|--------------|------------------------|-------------|-----|
| PLL 55.600.40.1/DALI  | 600 x 600   | diffuser opal      | 4000    | 53               | 5090               | 135                     | 605 x 605    | 10 - 30                | 12.70       | A+  |
| PLL 55.600.40.2/DALI  | 600 x 600   | diffuser prismatic | 4000    | 53               | 3840               | 135                     | 605 x 605    | 10 - 30                | 12.70       | A   |
| PLL 55.900.40.1/DALI  | 900 x 900   | diffuser opal      | 4000    | 112              | 11150              | 135                     | 905 x 905    | 10 - 30                | 23.00       | A+  |
| PLL 55.900.40.2/DALI  | 900 x 900   | diffuser prismatic | 4000    | 112              | 8930               | 135                     | 905 x 905    | 10 - 30                | 23.00       | A+  |
| PLL 55.1200.40.1/DALI | 1200 x 1200 | diffuser opal      | 4000    | 197              | 21660              | 135                     | 1205 x 1205  | 10 - 30                | 31.00       | A++ |
| PLL 55.1200.40.2/DALI | 1200 x 1200 | diffuser prismatic | 4000    | 197              | 16760              | 135                     | 1205 x 1205  | 10 - 30                | 31.00       | A+  |

Further product informations you will find under [www.lts-light.eu/2160](http://www.lts-light.eu/2160)

# PL 57

Recessed

housing made from sheet steel

tool-free ceiling mounting via quick-action clamping springs, adjustable ceiling thickness, Note! Consider the required installation space!

diffuser made from opal or prismatic acrylic glass, uniform lighting surface

flush ceiling look by filigree trim

**Note**

Also available as version with trimless ceiling look PL 55 (page 162) and as pendant and surface-mounted version PL 52 (page 160).

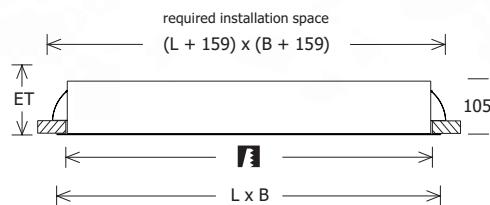

**Standard options**



**Special options**







Wolford, Bregenz, AUT · Planning: Wolford · Photo: Jean-Marc Delettre – Photography

## Range selection



| Article name          | L x B [mm]  | Feature            | CCT [K] | System power [W] | Luminous flux [lm] | Installation depth [mm] | Cut-out [mm] | Ceiling thickness [mm] | Weight [kg] | EEC |
|-----------------------|-------------|--------------------|---------|------------------|--------------------|-------------------------|--------------|------------------------|-------------|-----|
| PLL 57.625.40.1/DALI  | 626 x 626   | diffuser opal      | 4000    | 53               | 5090               | 135                     | 605 x 605    | 10 - 30                | 10.96       | A+  |
| PLL 57.625.40.2/DALI  | 626 x 626   | diffuser prismatic | 4000    | 53               | 3840               | 135                     | 605 x 605    | 10 - 30                | 10.96       | A   |
| PLL 57.925.40.1/DALI  | 926 x 926   | diffuser opal      | 4000    | 112              | 11150              | 135                     | 905 x 905    | 10 - 30                | 26.70       | A+  |
| PLL 57.925.40.2/DALI  | 926 x 926   | diffuser prismatic | 4000    | 112              | 8930               | 135                     | 905 x 905    | 10 - 30                | 26.70       | A+  |
| PLL 57.1225.40.1/DALI | 1226 x 1226 | diffuser opal      | 4000    | 197              | 21660              | 135                     | 1205 x 1205  | 10 - 30                | 44.50       | A++ |
| PLL 57.1225.40.2/DALI | 1226 x 1226 | diffuser prismatic | 4000    | 197              | 16760              | 135                     | 1205 x 1205  | 10 - 30                | 44.50       | A+  |

Further product informations you will find under [www.lts-light.eu/2161](http://www.lts-light.eu/2161)

# Trentino II

Ceiling

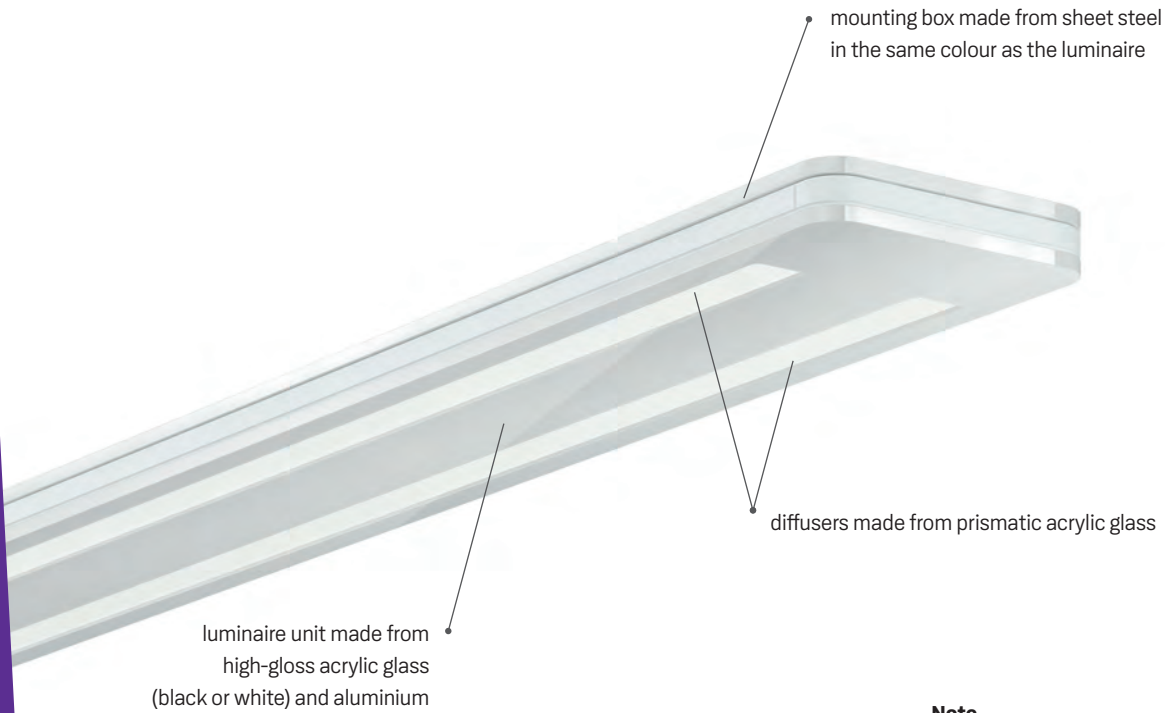

**Note**  
Also available as pendant luminaire (page 168) and free-standing luminaire (page 176).

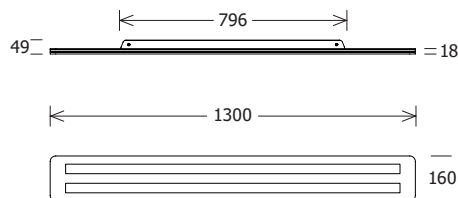

Standard options







WEIKL, Bodenmais, GER · Photo: Jean-Marc Delette – Photography

## Range selection

L80 B20  
50 000 h

CRI 80  
SDCM3

DALI



IP20

CE

KG  
7.8

| Article name        | Colour | CCT [K] | System power [W] | Luminous flux [lm] | EEC |
|---------------------|--------|---------|------------------|--------------------|-----|
| TNL 25.0540.02/DALI | black  | 4000    | 59               | 4530               | A+  |
| TNL 25.0540.03/DALI | white  | 4000    | 59               | 5210               | A+  |
| TNL 25.1040.02/DALI | black  | 4000    | 112              | 9060               | A+  |
| TNL 25.1040.03/DALI | white  | 4000    | 112              | 10410              | A+  |

Further product informations you will find under [www.lts-light.eu/2402](http://www.lts-light.eu/2402)



# Trentino II

Pendant

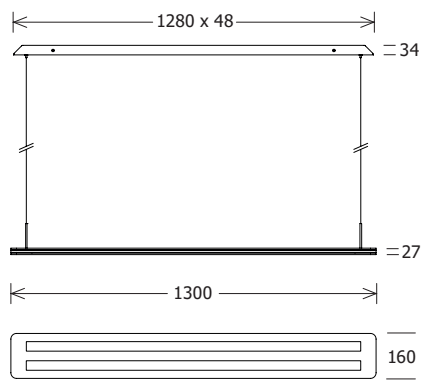
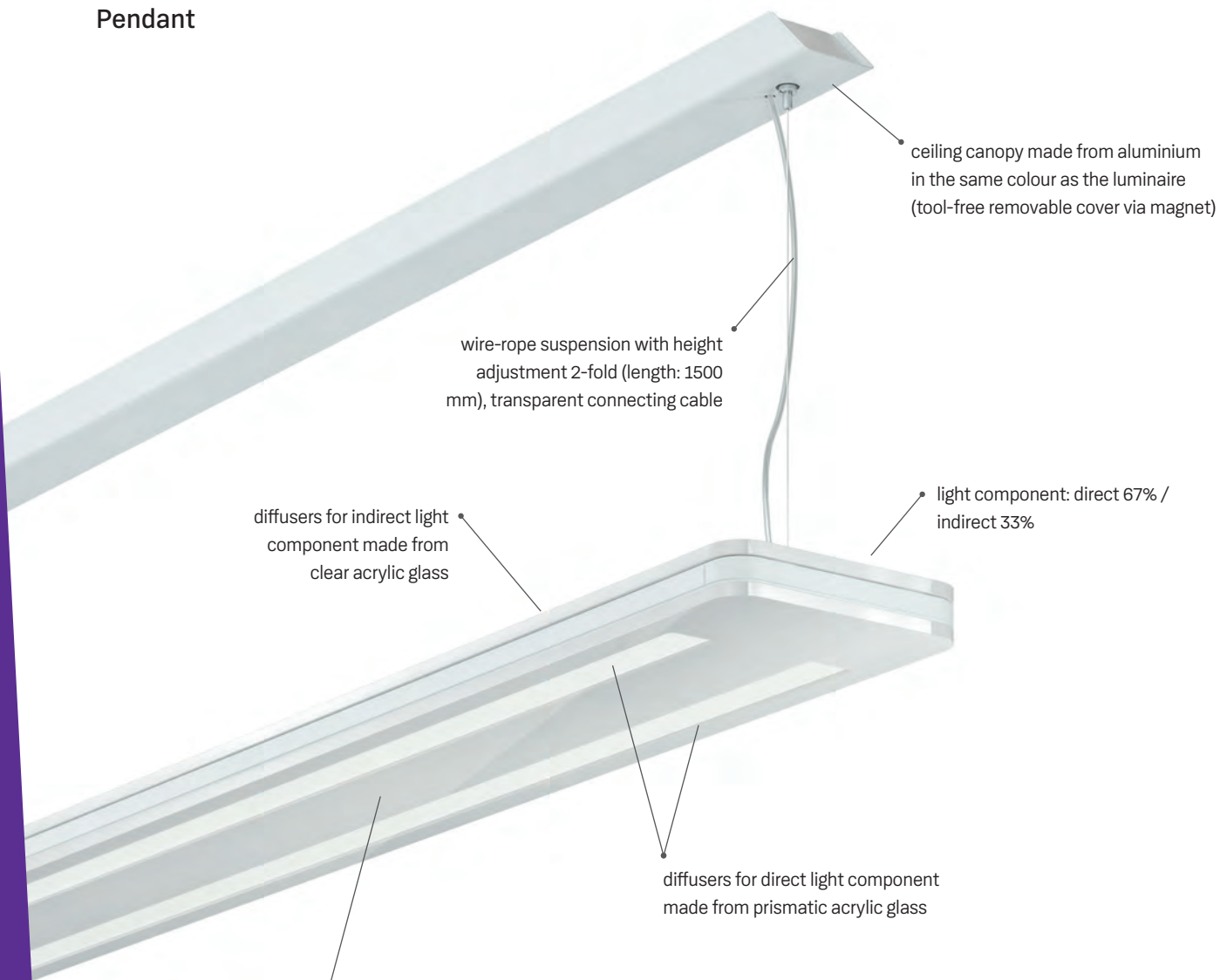

**Note**  
Also available as free-standing luminaire (page 176) and ceiling luminaire (page 166).

Standard options

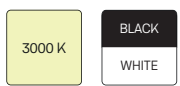



Feuerwehrhaus Lustenau, AUT · Planning: huber zt · Photo: 35 Millimeter Film und Fotografie Thierry Fiegler

## Range selection



| Article name        | Colour | CCT [K] | System power [W] | Luminous flux [lm] | UGR  | EEC |
|---------------------|--------|---------|------------------|--------------------|------|-----|
| TNL 22.0840.02/DALI | black  | 4000    | 83               | 5820               | 16.7 | A   |
| TNL 22.0840.03/DALI | white  | 4000    | 83               | 6620               | 17.9 | A+  |
| TNL 22.1640.02/DALI | black  | 4000    | 156              | 11630              | 19.0 | A+  |
| TNL 22.1640.03/DALI | white  | 4000    | 156              | 13230              | 19.0 | A+  |

Further product informations you will find under [www.lts-light.eu/2611](http://www.lts-light.eu/2611)



# FREE- STANDING LUMINAIRES

[www.lts-light.com/free-standing-luminaires](http://www.lts-light.com/free-standing-luminaires)





# Ascona

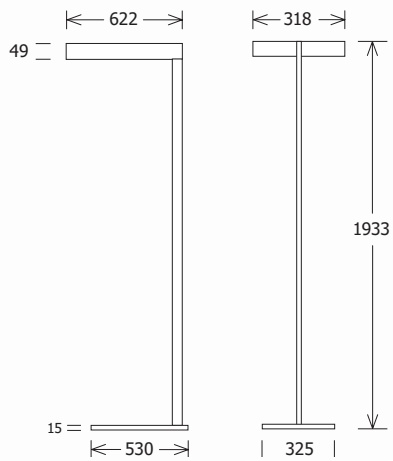
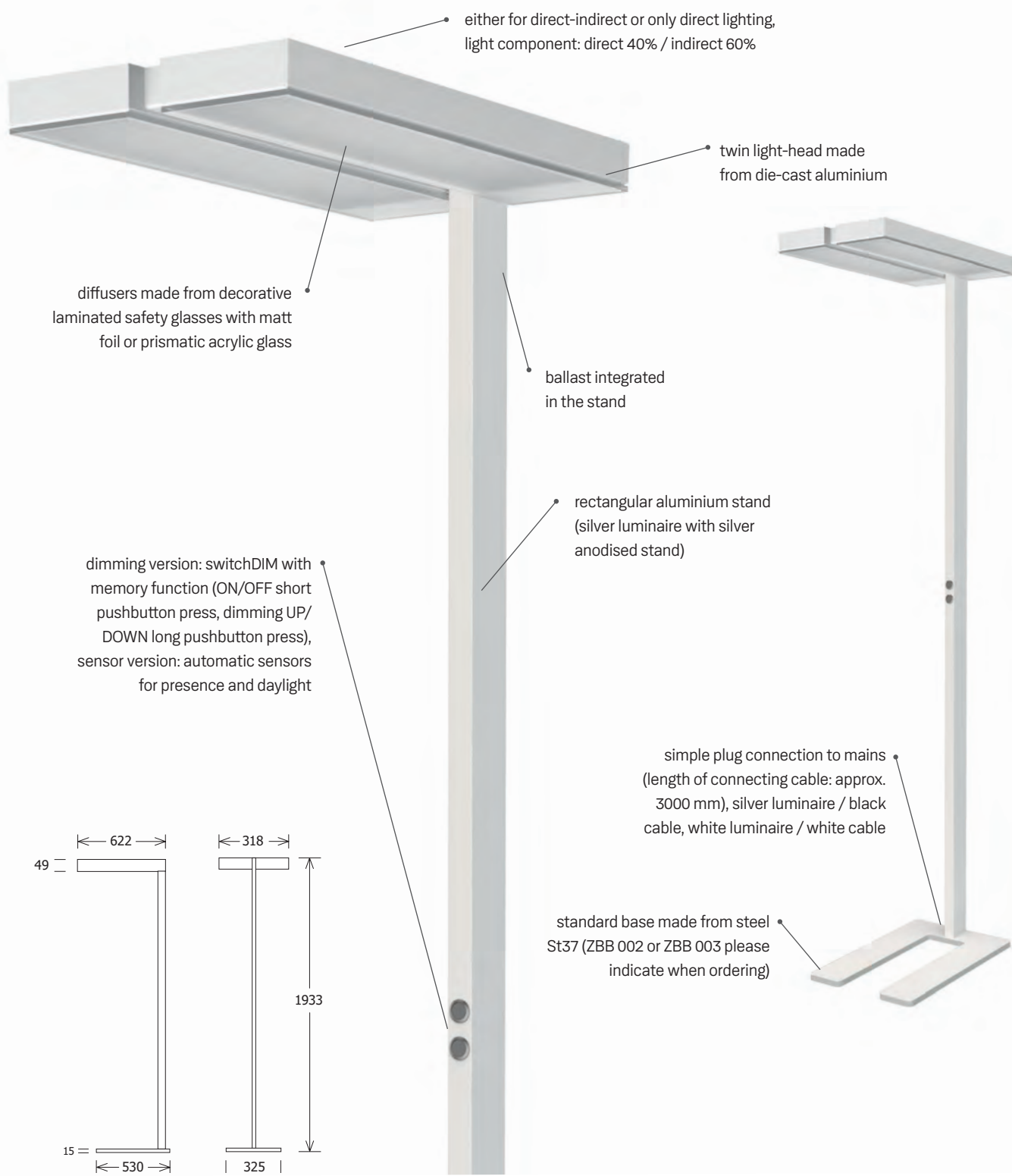

Standard options

|        |        |
|--------|--------|
| 3000 K | SILVER |
|        | WHITE  |



Wolford, Bregenz, AUT · Planning: Wolford · Photo: Jean-Marc Delettre – Photography

## Range selection



| Article name         | Feature  | CCT [K] | System power [W] | Luminous flux [lm] | UGR  | Weight [kg] | EEC |
|----------------------|--|---------|------------------|--------------------|------|-------------|-----|
| ASCL 10.0640.2 DIM   | direct / dimmable / decorative glass                   | 4000    | 50               | 3330               |      | 17.82       | A   |
| ASCL 10.0640.2 SENSO | direct / automatic sensors / decorative glass          | 4000    | 50               | 3330               |      | 17.82       | A   |
| ASCL 10.1140.1 DIM   | direct-indirect / dimmable / decorative glass          | 4000    | 101              | 8060               | 16.1 | 17.82       | A+  |
| ASCL 10.1140.1 SENSO | direct-indirect / automatic sensors / decorative glass | 4000    | 101              | 8060               | 16.1 | 17.82       | A+  |
| ASCL 11.0640.2 DIM   | direct / dimmable / prismatic glass                    | 4000    | 50               | 2960               | 17.2 | 17.06       | A   |
| ASCL 11.0640.2 SENSO | direct / automatic sensors / prismatic glass           | 4000    | 50               | 2960               | 17.2 | 17.06       | A   |
| ASCL 11.1140.1 DIM   | direct-indirect / dimmable / prismatic glass           | 4000    | 101              | 7770               | 10.0 | 17.06       | A+  |
| ASCL 11.1140.1 SENSO | direct-indirect / automatic sensors / prismatic glass  | 4000    | 101              | 7770               | 10.0 | 17.06       | A+  |

## Accessories

| Article name | Description                         |
|--------------|-------------------------------------|
| ZBB 002      | base version 2                      |
| ZBB 003      | base version 3                      |
| ZBC 001      | remote control for SENSO luminaires |

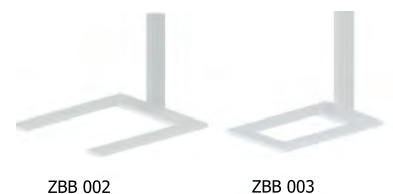

Further product informations you will find under [www.lts-light.eu/2701](http://www.lts-light.eu/2701)



# Piano

## Stand

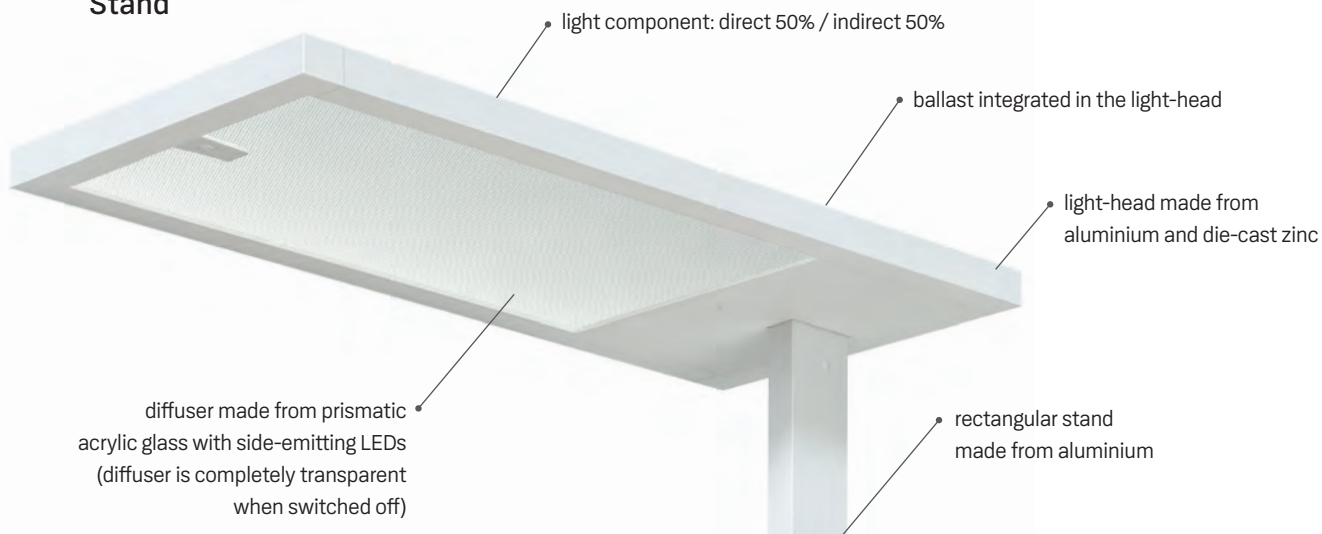

dimming version: switchDIM with memory function (ON/OFF short pushbutton press, dimming UP/DOWN long pushbutton press), sensor version: automatic sensors for presence and daylight, trooping version: communication system between luminaires for light and movement

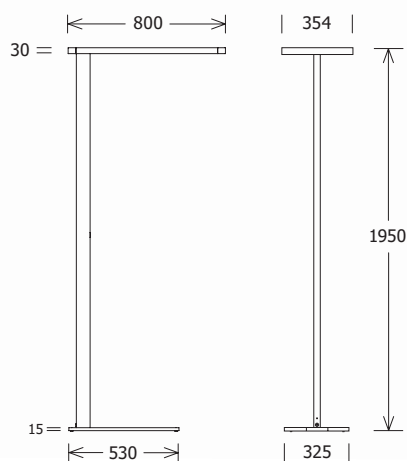

simple plug connection to mains (length of connecting cable: approx. 3000 mm), black and silver luminaire / black cable, white luminaire / white cable

standard base made from steel St37 (ZBB 002 or ZBB 003 please indicate when ordering)

**Note**

Also available as pendant luminaire (page 144).

**Standard options**

|        |     |        |          |                          |
|--------|-----|--------|----------|--------------------------|
| 3000 K | DIM | SENSOR | TROOPING | BLACK<br>SILVER<br>WHITE |
|--------|-----|--------|----------|--------------------------|

**Special options**

|     |      |            |     |
|-----|------|------------|-----|
| TWL | TWPI | LUMEN PLUS | RAL |
|-----|------|------------|-----|



Evans, General Contractors, Friedrichshafen, GER

## Range selection



| Article name           | Feature           | CCT [K] | System power [W] | Luminous flux [lm] | UGR  | Weight [kg] | EEC |
|------------------------|-------------------|---------|------------------|--------------------|------|-------------|-----|
| PIANO-S 080.0540/DIM   | dimnable          | 4000    | 63               | 6320               | 19.0 | 22.15       | A+  |
| PIANO-S 080.0540/SENSO | automatic sensors | 4000    | 63               | 6320               | 19.0 | 22.32       | A+  |
| PIANO-S 080.0540/TROOP | trooping          | 4000    | 63               | 6320               | 19.0 | 22.42       | A+  |
| PIANO-S 080.0840/DIM   | dimnable          | 4000    | 88               | 8340               | 19.0 | 22.15       | A+  |
| PIANO-S 080.0840/SENSO | automatic sensors | 4000    | 88               | 8340               | 19.0 | 22.32       | A+  |
| PIANO-S 080.0840/TROOP | trooping          | 4000    | 88               | 8340               | 19.0 | 22.42       | A+  |

## Accessories

| Article name | Description                         |
|--------------|-------------------------------------|
| ZBB 002      | luminaire base version 2            |
| ZBB 003      | luminaire base version 3            |
| ZBC 001      | remote control for SENSO luminaires |



ZBB 002

ZBB 003

Further product informations you will find under [www.lts-light.eu/2706](http://www.lts-light.eu/2706)

# Trentino II

## Stand



### Standard options

- 3000 K
-   
 DIM
-   
 SENSOR
- BLACK  
 WHITE





Villa Stöcken, Solingen, GER · Photo: Leon Sinowenka Photographie

## Range selection



| Article name         | Colour | Feature           | CCT [K] | System power [W] | Luminous flux [lm] | UGR  | EEC  |
|----------------------|--------|-------------------|---------|------------------|--------------------|------|------|
| TNL 20.1040.02/DIM   | black  | dimmable          | 4000    | 102              | 7950               | 19.0 | A+ → |
| TNL 20.1040.03/DIM   | white  | dimmable          | 4000    | 102              | 8950               | 19.0 | A+ → |
| TNL 20.1040.02/SENSO | black  | automatic sensors | 4000    | 102              | 7950               | 19.0 | A+ → |
| TNL 20.1040.03/SENSO | white  | automatic sensors | 4000    | 102              | 8950               | 19.0 | A+ → |

## Accessories

| Article name | Description                         |
|--------------|-------------------------------------|
| ZBB 002      | luminaire base version 2            |
| ZBB 003      | luminaire base version 3            |
| ZBC 001      | remote control for SENSO luminaires |



ZBB 002

ZBB 003

Further product informations you will find under [www.lts-light.eu/2704](http://www.lts-light.eu/2704)



# WALL LUMINAIRES

[www.lts-light.com/wall-luminaires](http://www.lts-light.com/wall-luminaires)





# LUZ

Wall

indirect lighting with asymmetrical light distribution (beaming forward), lense optics made from PMMA plastic

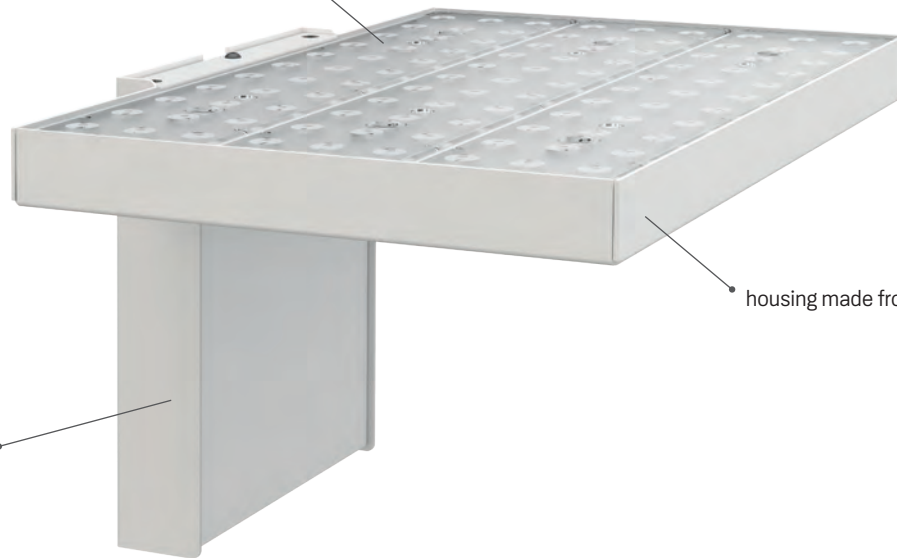

housing made from sheet steel

wall mounting box made from sheet steel

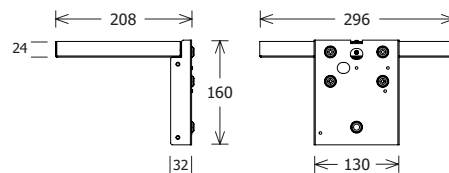

Standard options



Special options





AWO, Bremen, GER - Photo: Henning Stauch Photography

## Range selection



| Article name           | CCT [K] | System power [W] | Luminous flux [lm] | EEC |
|------------------------|---------|------------------|--------------------|-----|
| LUZ23-W 31.013.30/DALI | 3000    | 46               | 5180               |     |

Further product informations you will find under [www.lts-light.eu/2517](http://www.lts-light.eu/2517)

# PL 23

Wall

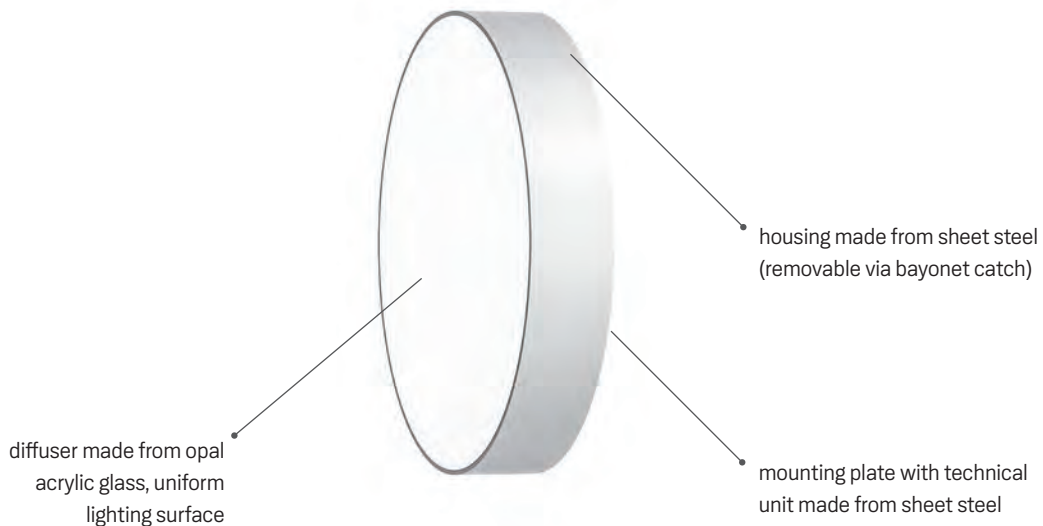

**Note**

Also available as surface-mounted/pendant luminaire PL 22 (page 148), recessed luminaires PL 25 and PL 27 (pages 150 and 154) and direct-indirect versions PL 26 and PL 28 (pages 152 and 156).

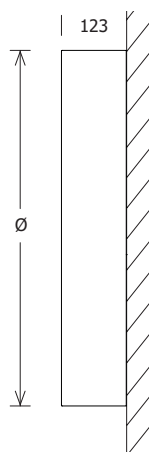

Standard options



Special options

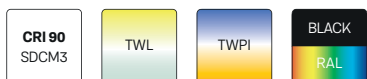





Light + Building 2016, Frankfurt, GER · Photo: Werner Huthmacher Photography

## Range selection



| Article name          | Ø [mm] | Feature       | CCT [K] | System power [W] | Luminous flux [lm] | Weight [kg] | EEC |
|-----------------------|--------|---------------|---------|------------------|--------------------|-------------|-----|
| PLL 23.385.40.1/DALI  | 385    | diffuser opal | 4000    | 22               | 1890               | 3.78        | A+  |
| PLL 23.475.40.1/DALI  | 475    | diffuser opal | 4000    | 39               | 3570               | 4.80        | A+  |
| PLL 23.675.40.1/DALI  | 675    | diffuser opal | 4000    | 75               | 8030               | 9.62        | A++ |
| PLL 23.1000.40.1/DALI | 1000   | diffuser opal | 3000    | 164              | 17640              | 19.00       | A++ |

Further product informations you will find under [www.lts-light.eu/2513](http://www.lts-light.eu/2513)

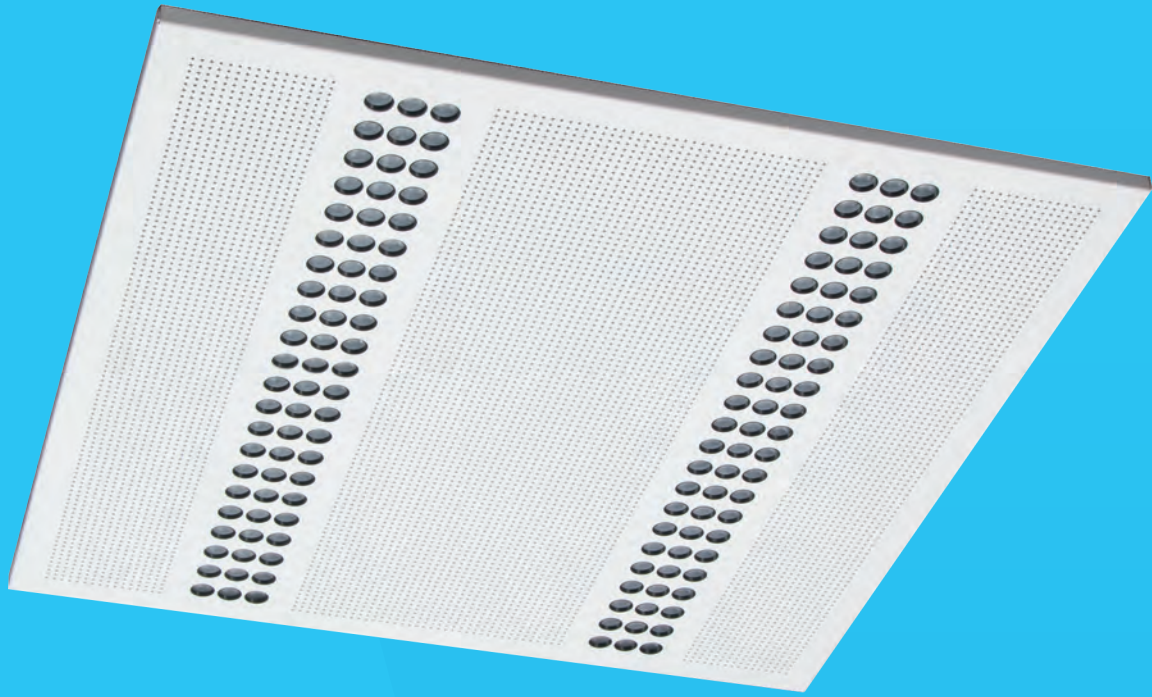

# INSERT LUMINAIRES

[www.lts-light.com/insert-luminares](http://www.lts-light.com/insert-luminares)







# Fyrra

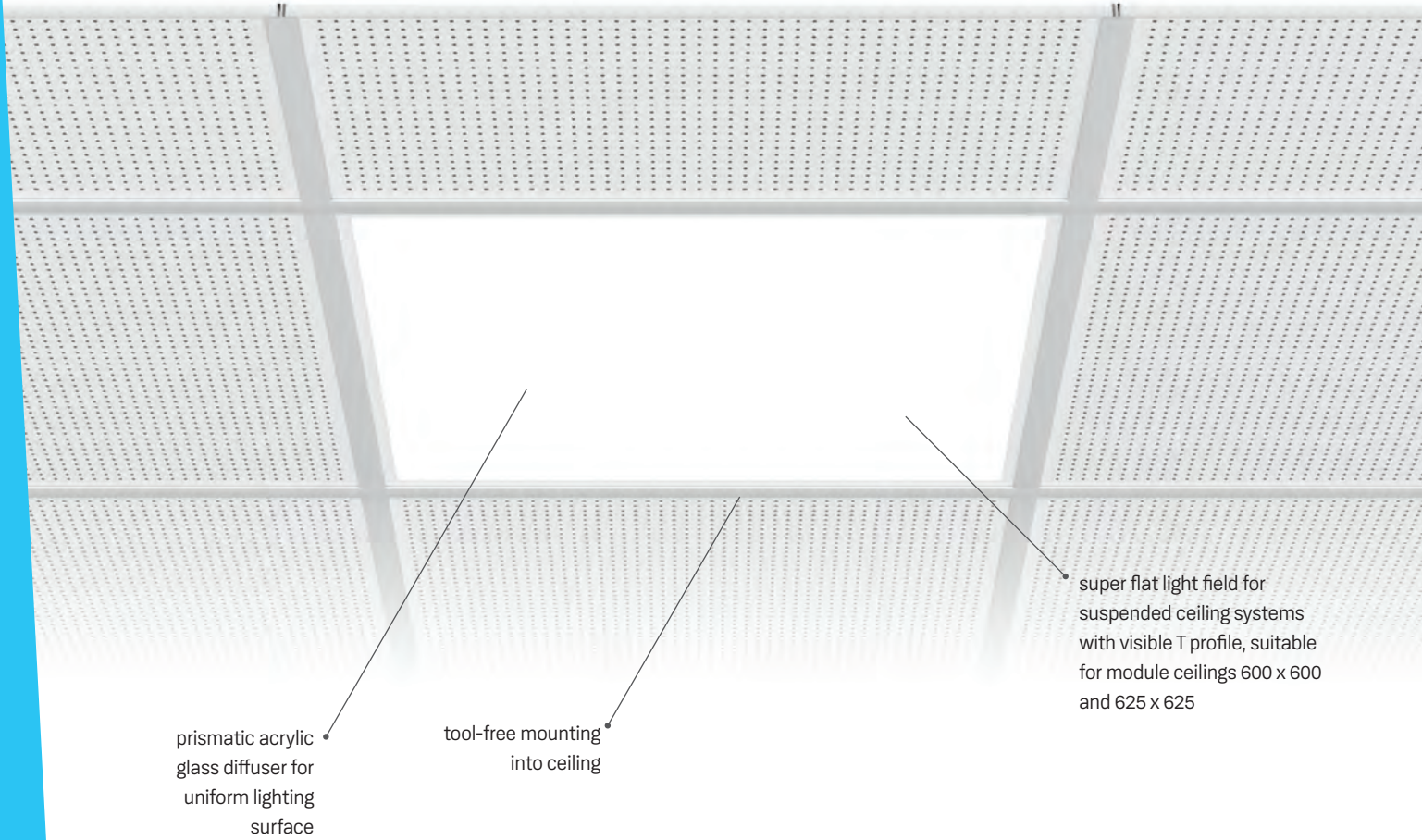

prismatic acrylic glass diffuser for uniform lighting surface

tool-free mounting into ceiling

super flat light field for suspended ceiling systems with visible T profile, suitable for module ceilings 600 x 600 and 625 x 625

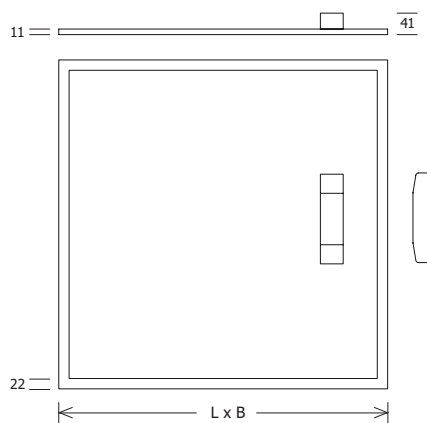

Standard options





Theodor-Fontane-Schule, Leverkusen, GER · Planning: Architekturbüro Eberhard Foes · Photo: Professionelle Fotografie Peter Frese

## Range selection



| Article name     | Module    | L x B [mm] | CCT [K] | System power [W] | Luminous flux [lm] | UGR  | Installation depth [mm] | Weight [kg] | EEC |
|------------------|-----------|------------|---------|------------------|--------------------|------|-------------------------|-------------|-----|
| FYR-E 10.0600.40 | 600 x 600 | 595 x 595  | 4000    | 36               | 4210               | 18.5 | 41                      | 3.75        | A++ |
| FYR-E 10.0625.40 | 625 x 625 | 620 x 620  | 4000    | 36               | 4210               | 18.3 | 41                      | 3.78        | A++ |

## Accessories

| Article name   | Description                              |
|----------------|--|
| FYR-Z 10.01.01 | Y wire-rope suspension (length: 1500 mm) |

Further product informations you will find under [www.its-light.eu/2433](http://www.its-light.eu/2433)



# Optico

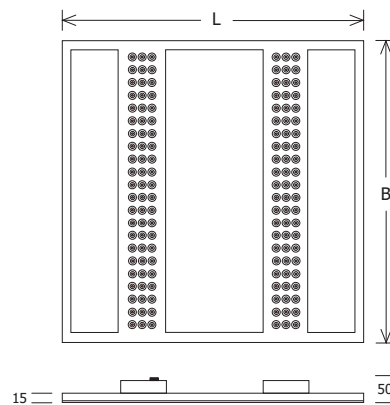
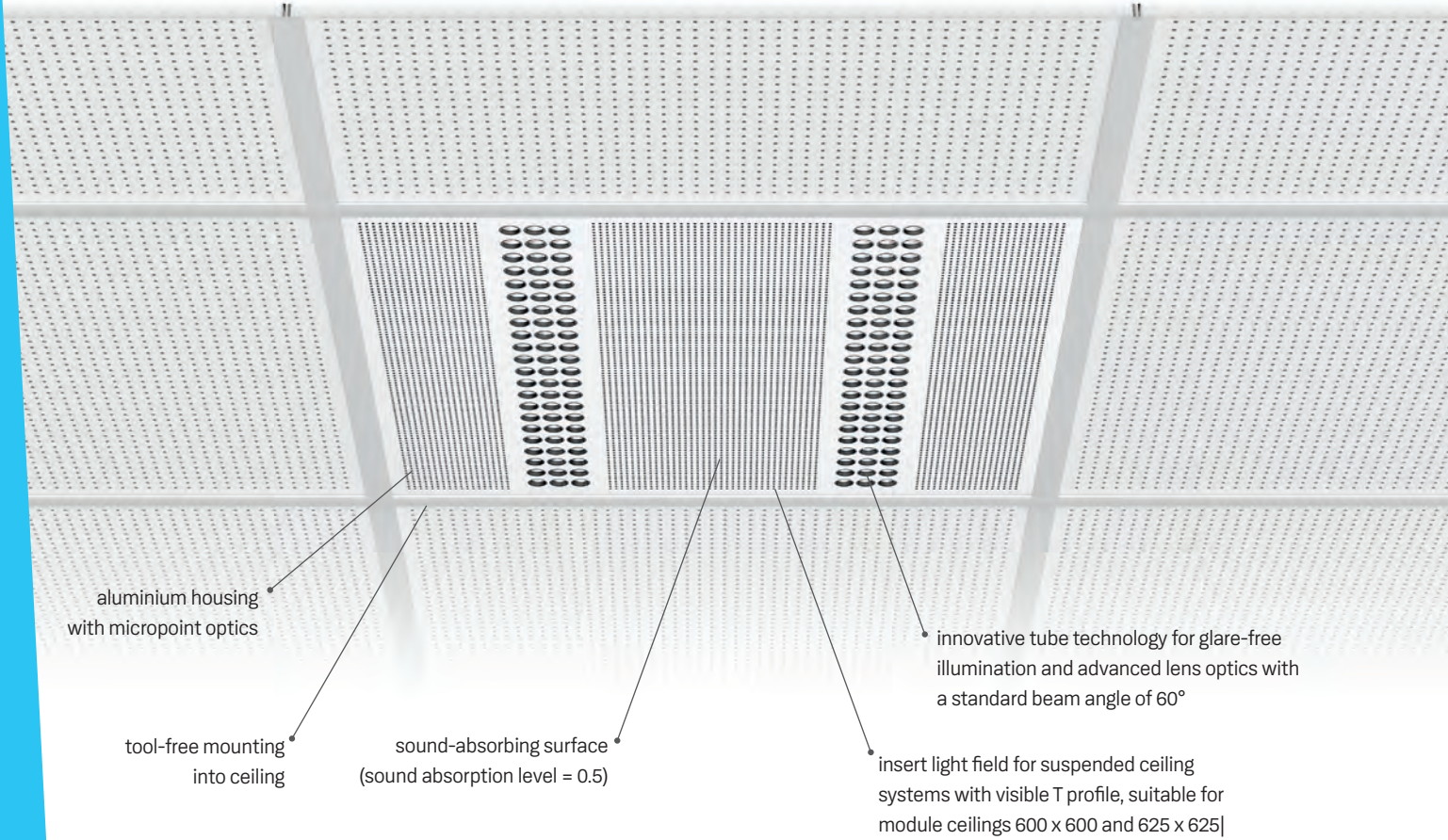

**Standard options**



**Special options**







Hermann Müller Elektrogroßhandel, Weingarten, GER · Photo: Jean-Marc Delette – Photography

## Range selection



| Article name            | Module    | L x B [mm] | CCT [K] | System power [W] | Luminous flux [lm] | UGR  | Installation depth [mm] | Weight [kg] | EEC |
|-------------------------|-----------|------------|---------|------------------|--------------------|------|-------------------------|-------------|-----|
| OPT-R 104.0600.840/DALI | 600 x 600 | 592 x 592  | 4000    | 42               | 4560               | 12.5 | 150                     | 4.17        | A++ |
| OPT-R 104.0625.840/DALI | 625 x 625 | 617 x 617  | 4000    | 42               | 4560               | 12.5 | 150                     | 4.48        | A++ |
| OPT-R 106.0600.840/DALI | 600 x 600 | 592 x 592  | 4000    | 62               | 6550               | 13.7 | 150                     | 4.17        | A++ |
| OPT-R 106.0625.840/DALI | 625 x 625 | 617 x 617  | 4000    | 62               | 6550               | 13.7 | 150                     | 4.48        | A++ |

Further product informations you will find under [www.lts-light.eu/2437](http://www.lts-light.eu/2437)



# HIGH-BAY LUMINAIRES

[www.lts-light.com/high-bay-luminaires](http://www.lts-light.com/high-bay-luminaires)





BARTH Präzisionstechnik, Ertingen, GER · Photo: Rampant-Pictures Werbefotografie



# FLC

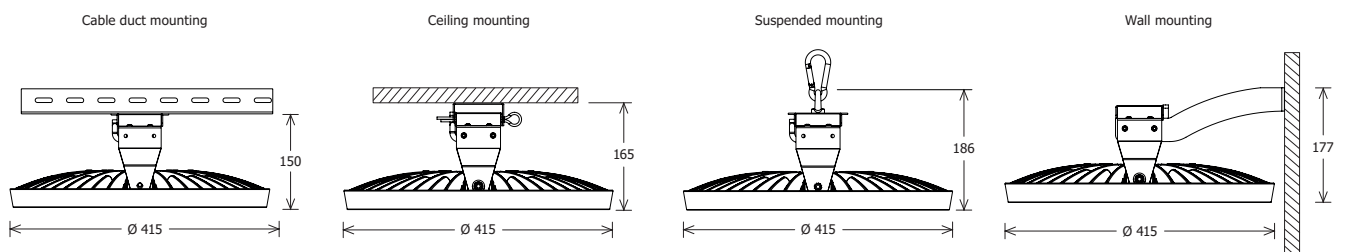

Special options





BARTH Präzisionstechnik, Ertingen, GER · Photo: Rampant-Pictures Werbefotografie



## Range selection

| Article name      | Feature      | Fixing     | Beam angle | CCT [K] | System power [W] | Luminous flux [lm] | Weight [kg] | EEC |
|-------------------|--------------|------------|------------|---------|------------------|--------------------|-------------|-----|
| FLCK-A 415.150.40 | lens optics  | ceiling    | 66°        | 4000    | 106              | 14850              | 7.14        | A++ |
| FLCK-K 415.150.40 | lens optics  | cable duct | 66°        | 4000    | 106              | 14850              | 7.20        | A++ |
| FLCK-P 415.150.40 | lens optics  | suspended  | 66°        | 4000    | 106              | 14850              | 6.80        | A++ |
| FLCK-W 415.150.40 | lens optics  | wall       | 66°        | 4000    | 106              | 14850              | 7.40        | A++ |
| FLCK-A 415.200.40 | lens optics  | ceiling    | 66°        | 4000    | 152              | 19980              | 7.14        | A++ |
| FLCK-K 415.200.40 | lens optics  | cable duct | 66°        | 4000    | 152              | 19980              | 7.20        | A++ |
| FLCK-P 415.200.40 | lens optics  | suspended  | 66°        | 4000    | 152              | 19980              | 6.80        | A++ |
| FLCK-W 415.200.40 | lens optics  | wall       | 66°        | 4000    | 152              | 19980              | 7.40        | A++ |
| FLCA-A 415.135.40 | safety glass | ceiling    | 100°       | 4000    | 106              | 13350              | 7.28        | A++ |
| FLCA-K 415.135.40 | safety glass | cable duct | 100°       | 4000    | 106              | 13350              | 7.34        | A++ |
| FLCA-P 415.135.40 | safety glass | suspended  | 100°       | 4000    | 106              | 13350              | 7.29        | A++ |
| FLCA-W 415.135.40 | safety glass | wall       | 100°       | 4000    | 106              | 13350              | 8.00        | A++ |
| FLCA-A 415.180.40 | safety glass | ceiling    | 100°       | 4000    | 152              | 17890              | 7.28        | A++ |
| FLCA-K 415.180.40 | safety glass | cable duct | 100°       | 4000    | 152              | 17890              | 7.34        | A++ |
| FLCA-P 415.180.40 | safety glass | suspended  | 100°       | 4000    | 152              | 17890              | 7.29        | A++ |
| FLCA-W 415.180.40 | safety glass | wall       | 100°       | 4000    | 152              | 17890              | 8.00        | A++ |

Further product informations you will find under [www.lts-light.eu/2634](http://www.lts-light.eu/2634)

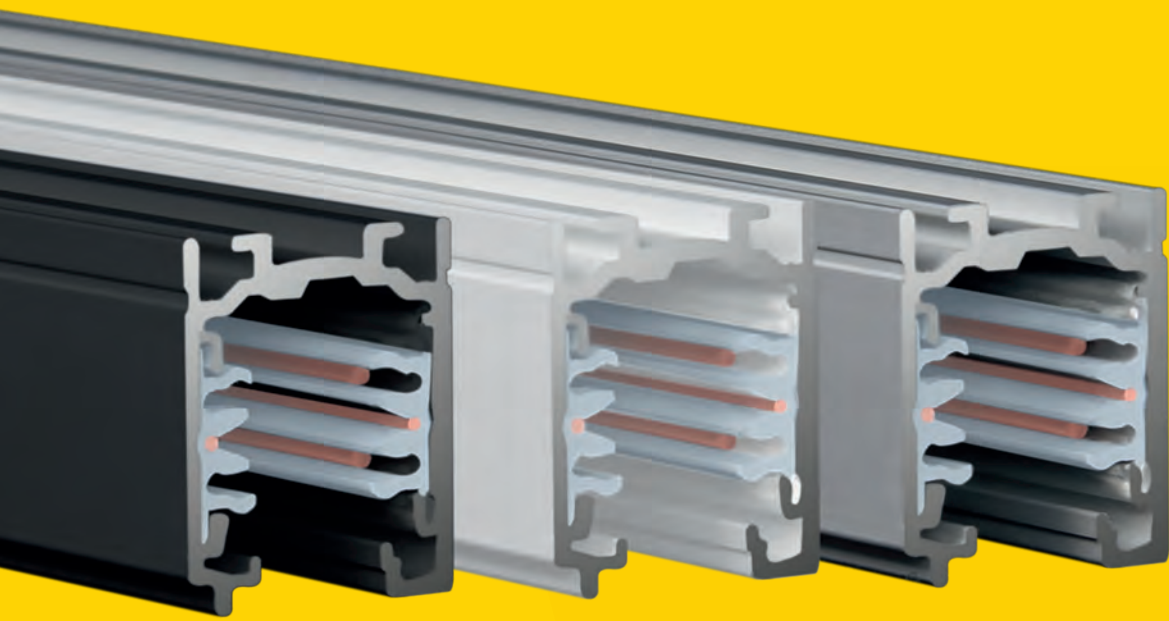

# CONTACT TRACKS & ACCESSORIES

[www.lts-light.com/accessories](http://www.lts-light.com/accessories)







# THE NEW UNIVERSAL SYSTEM

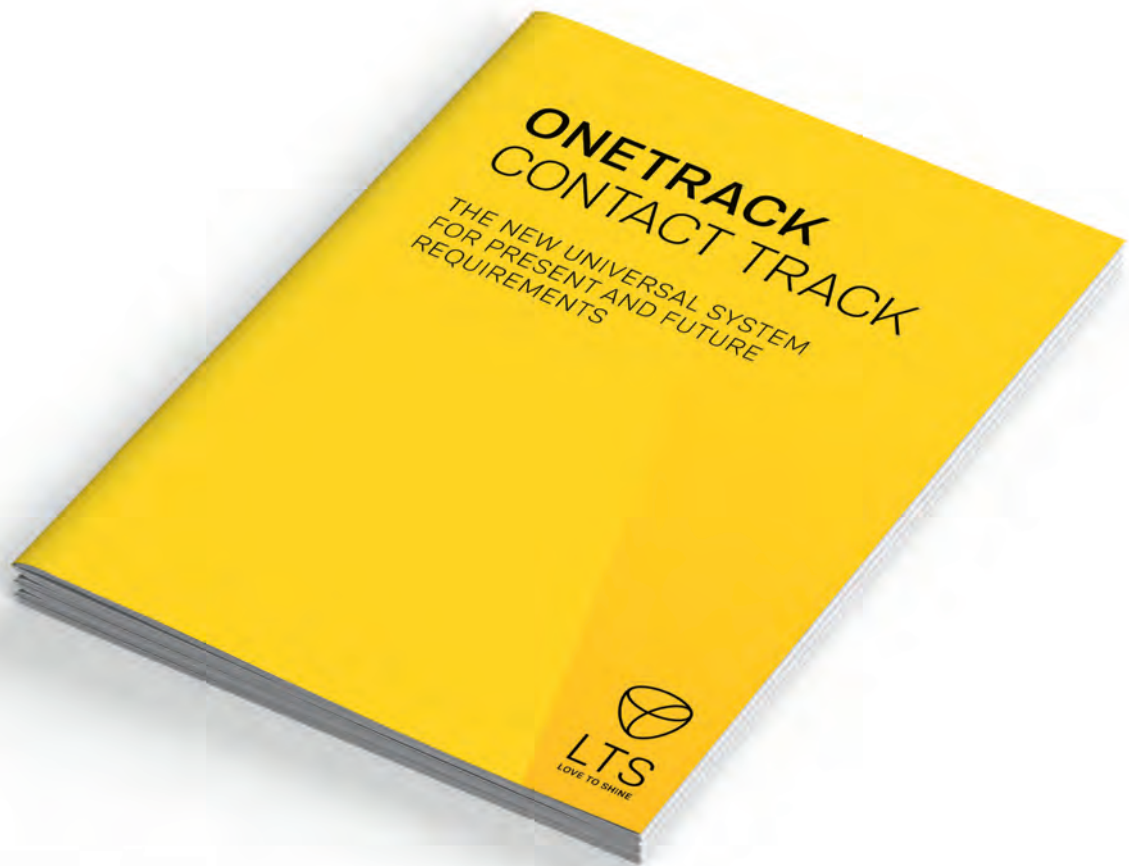

The new ONETRack brochure available for download:  
[www.lts-light.com/downloads/brochures](http://www.lts-light.com/downloads/brochures)

# ONETRACK

## THE FLEXIBLE SOLUTION

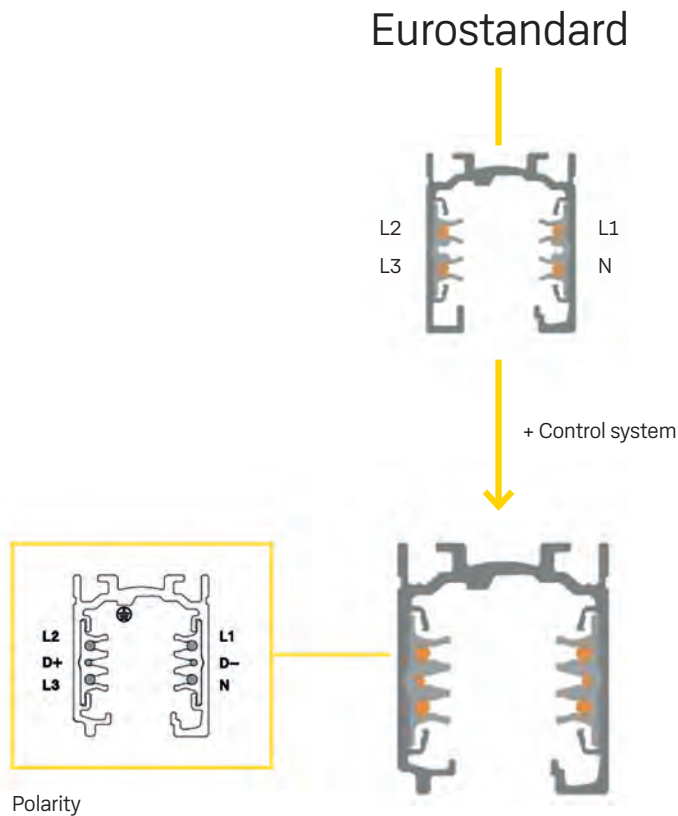

The new track ONETRACK combines the currently available systems on the market. It has 6-conductors with individually switchable circuits and in addition it is equipped with a control system. ONETRACK is therefore an ideal solution for realization of lighting with DALI and also for Human Centric Lighting applications.

At every phase of the project, without any restrictions, one has the ability to decide on new lights that should be used. The track is available in built-in or surface-mounted variants and thus it is a universal and above all future-proof single solution.

With a versatile range of connectors, ONETRACK can be tailor-made for any length and shape requirements. This universal system also allows on-site length adjustment through easy shortening. Thanks to the intelligently designed accessories they successfully aid in easy installation.

The new track is a perfect companion for our high-efficiency spotlights and linear lighting solutions.





# ONETrack

## Surface-Mounted

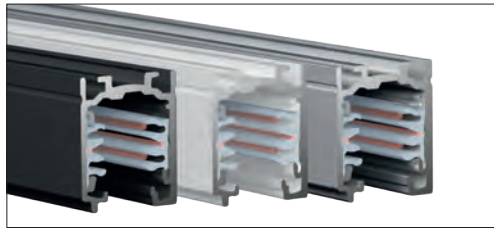

| Article name      | Length  |
|-------------------|---------|
| ST-A 10/9000-1-ST | 1000 mm |
| ST-A 20/9000-2-ST | 2000 mm |
| ST-A 30/9000-3-ST | 3000 mm |
| ST-A 40/9000-4-ST | 4000 mm |

black, white, grey (aluminum)

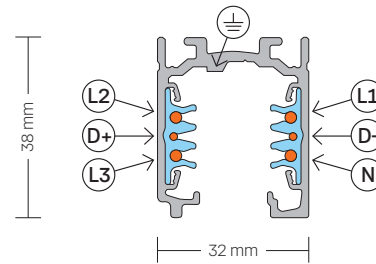

**ST-A F/PE-R/9001**  
End feeder with polarity right

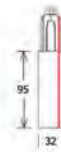

**ST-A F/PE-L/9002**  
End feeder with polarity left



**ST-IE/9003**  
Electric linear connector (inside)



**ST-A I/9010**  
Electric linear connector

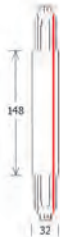

**ST-A L/PE-IN/9011**  
L-connector with polarity inside

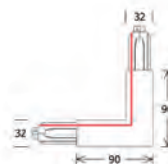

**ST-A L/PE-OUT/9012**  
L-connector with polarity outside

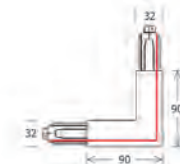

**ST-A T/PE-OUT-L/9013**  
T-connector with polarity outside left

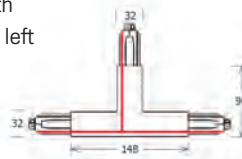

**ST-A T/PE-OUT-R/9014**  
T-connector with polarity outside right

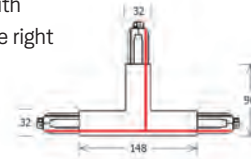

**ST-A T/PE-IN-L/9015**  
T-connector with polarity inside left



**ST-A T/PE-IN-R/9016**  
T-connector with polarity inside right

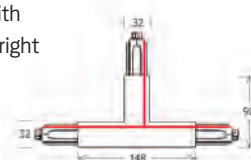

**ST-A X/9017**  
X-connector

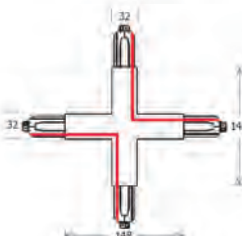

**ST-A FLEX/9018**  
Flexible connector







# ONETrack

Recessed



| Article name     | Length  |
|------------------|---------|
| ST-E 10/9000-1-R | 1000 mm |
| ST-E 20/9000-2-R | 2000 mm |
| ST-E 30/9000-3-R | 3000 mm |
| ST-E 40/9000-4-R | 4000 mm |

black, white, grey (aluminum)

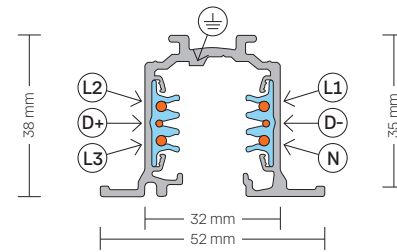

**ST-E F/PE-R/9001**  
End feeder with polarity right

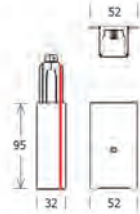

**ST-E F/PE-L/9002**  
End feeder with polarity left



**ST-IE/9003**  
Electric linear connector (inside)



**ST-E I/9010**  
Electric linear connector

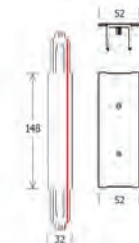

**ST-E L/PE-IN/9011**  
L-connector with polarity inside

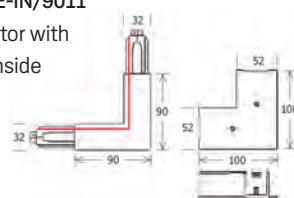

**ST-E L/PE-OUT/9012**  
L-connector with polarity outside

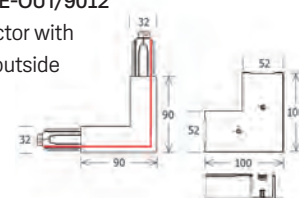

**ST-E T/PE-OUT-L/9013**  
T-connector with polarity outside left

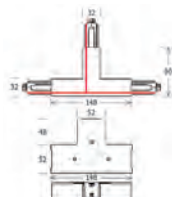

**ST-E T/PE-OUT-R/9014**  
T-connector with polarity outside right

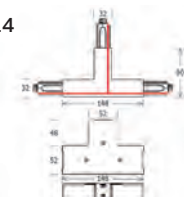

**ST-E T/PE-IN-L/9015**  
T-connector with polarity inside left

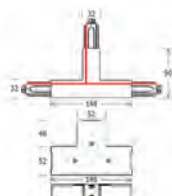

**ST-E T/PE-IN-R/9016**  
T-connector with polarity inside right

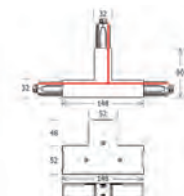

**ST-E X/9017**  
X-connector

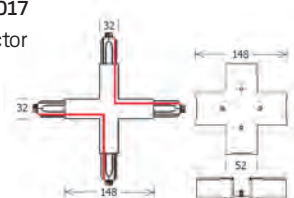

**ST-E MONO/9000-BP-D**  
3-phase adapter

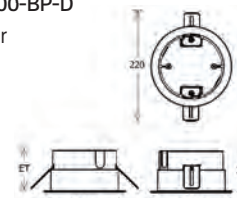





**ST-E CAP/9004-R**  
End cover

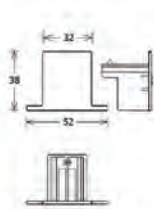

**ST-A 30**  
ONETrack  
adapter  
black, white

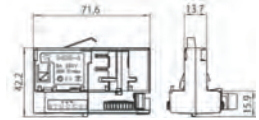

**ST-A 30 M10**  
ONETrack  
adapter with  
threaded nipple  
M10  
black, white

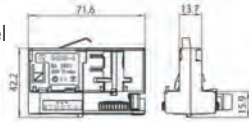

**ST-A 30 M13**  
ONETrack  
adapter with  
threaded nipple  
M13  
black, white

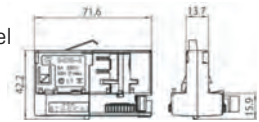

**ST-A 30B M13**  
ONETrack  
adapter DALI  
with threaded  
nippel M13  
black, white



**ST-ZCOV/S-9000/GP**  
Cover strip  
black, white, grey

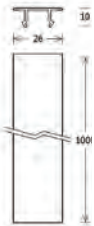

**ST-ZCOV/S-9000/TP**  
Cap



**ST-ZSCHUKO/4230V**  
Socket adapter  
for 3-phase track  
black, white

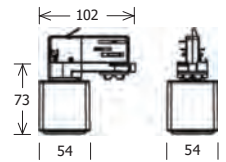

**ST-E S/S-9000-313**  
Pendant bracket  
for 3-phase  
recessed track  
grey (aluminum)

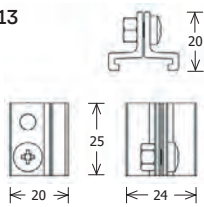

# ONETrack

Surface-Mounted & Recessed · Polarity

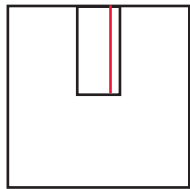

End feeder  
conductor right  
9001

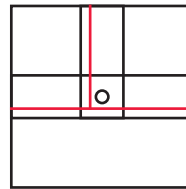

T-connector  
conductor outside left  
9013

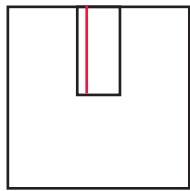

End feeder  
conductor left  
9002

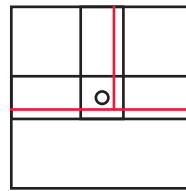

T-connector  
conductor outside right  
9014

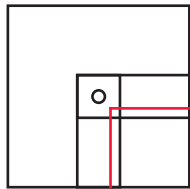

L-connector  
conductor inside  
9011

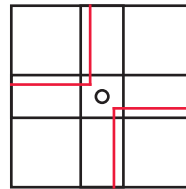

X-connector  
9017

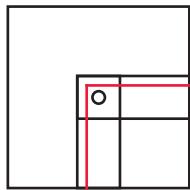

L-connector  
conductor outside  
9012

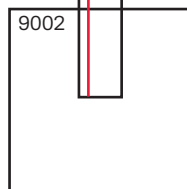
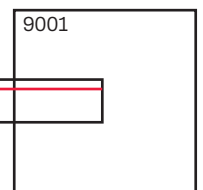
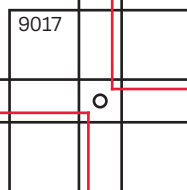
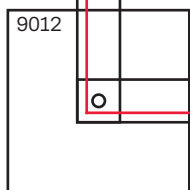
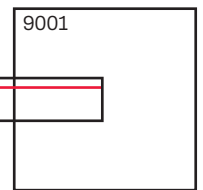
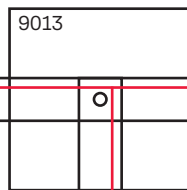
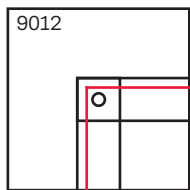

# ONETrack

## 3-phase track and control signal

The ONETrack system is a 3 phase mixed system with two additional conductors intended to manage a general data signal (for example dali, dmx, lon, eib, etc.). The system is EN 60570 certified and its installation must be accomplished by highly qualified person. There are four possible installation systems: directly on ceiling or on wall, using the mounting holes (pic. 1a)

on the track (use a countersink head screw, pic. 1b), on ceiling or on wall using a metal clip (code S-9000/111), hanging by the suspension (see the catalog) or recessed without exceeding the maximum loads (pic. 2). During the wiring the electrical the scheme of pic. 3 must be followed.

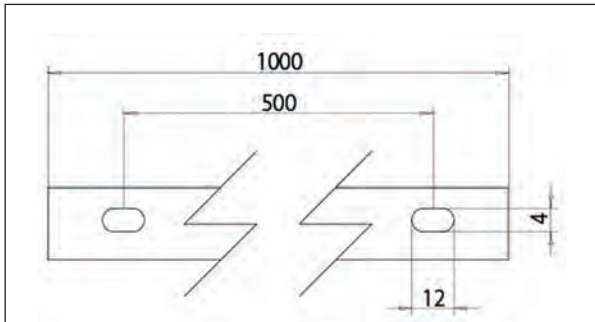

Fig. 1a Mounting holes position

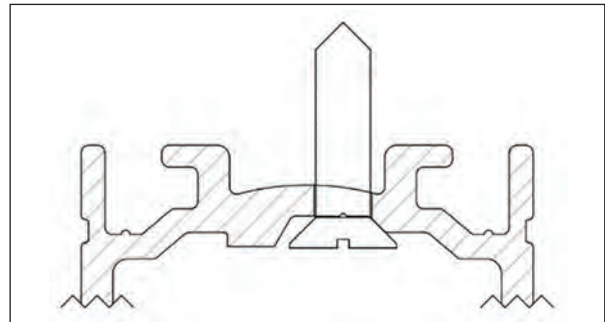

Fig. 1b Screw position

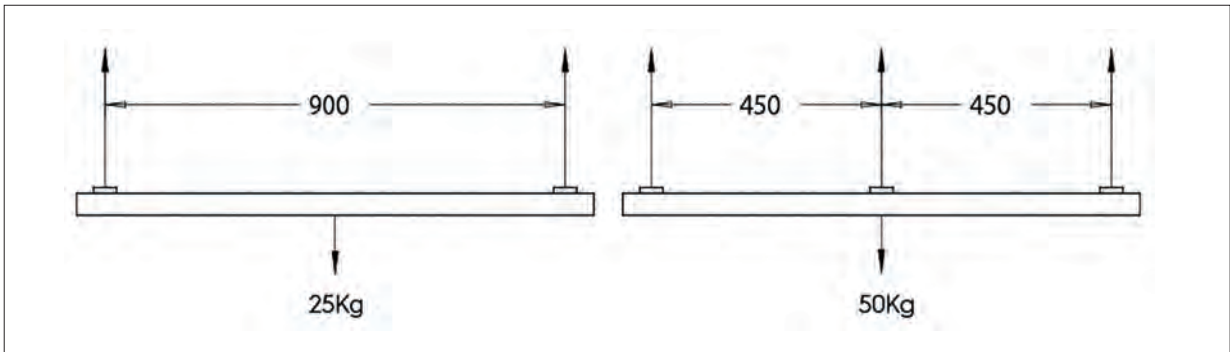

Fig. 2 Load scheme

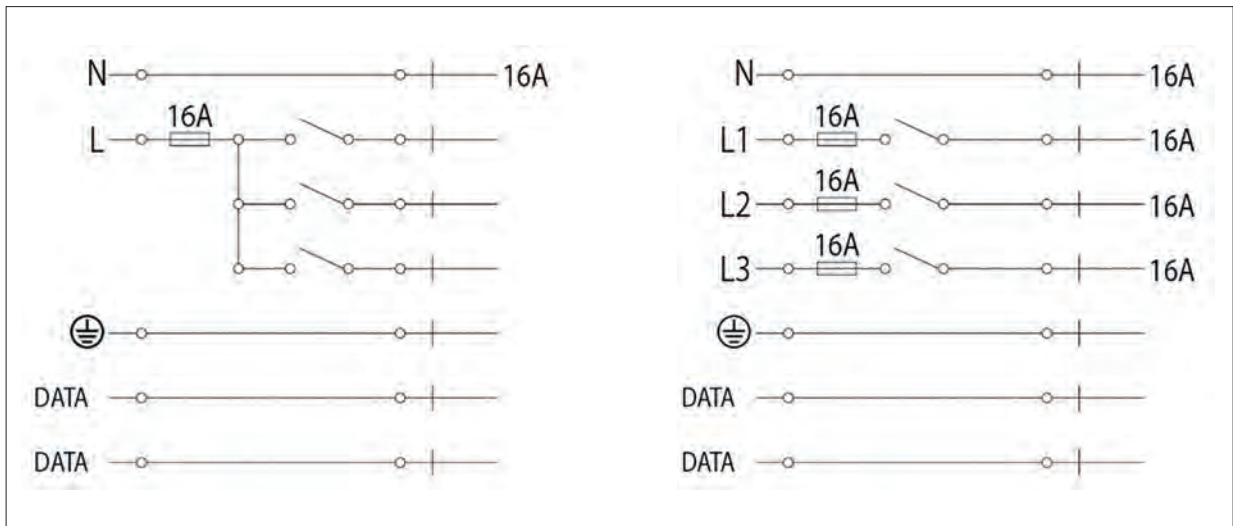

Fig. 3 Electrical scheme



# Index

Variety from A – Z

| Article name                                  | Page | Article name                           | Page |
|---|------|--|------|
| <b>A</b>                                      |      | <b>M</b>                               |      |
| Ascona  | 172  | Monoline 070 Surface-Mounted & Pendant | 140  |
| <b>B</b>                                      |      | <b>O</b>                               |      |
| Bixx 100                                      | 38   | Optico                                 | 188  |
| BixxL 200                                     | 40   | ONETrack Surface-Mounted               | 198  |
| Button 300                                    | 94   | ONETrack Recessed                      | 200  |
| Button Mini 100/200                           | 96   | <b>P</b>                               |      |
| <b>C</b>                                      |      | Piano Pendant                          | 144  |
| CSA 40  | 58   | Piano Stand                            | 174  |
| CSA 50  | 60   | PL 20 Surface-Mounted & Pendant        | 146  |
| CSA 60  | 62   | PL 22 Surface-Mounted & Pendant        | 148  |
| CSA 72 Round                                  | 64   | PL 23 Wall                             | 182  |
| <b>D</b>                                      |      | PL 25 Recessed Trimless                | 150  |
| Dallton Large                                 | 72   | PL 26 Direct-Indirect Surface-Mounted  | 152  |
| Dallton Medium                                | 70   | PL 27 Recessed                         | 154  |
| Dallton Small                                 | 68   | PL 28 Direct-Indirect Pendel           | 156  |
| Dallton XSmall                                | 66   | PL 50 Surface-Mounted & Pendant        | 158  |
| <b>E</b>                                      |      | PL 52 Surface-Mounted & Pendant        | 160  |
| EuroLED                                       | 42   | PL 55 Recessed Trimless                | 162  |
| <b>F</b>                                      |      | PL 57 Recessed                         | 164  |
| Flixx 100/200 Round                           | 100  | <b>S</b>                               |      |
| Flixx 100/200 Square                          | 102  | Scene 1 System                         | 76   |
| Flixx 300 Flat Round                          | 104  | Scene 33 System                        | 78   |
| Flixx 300/400 Round                           | 106  | Scene 4 System                         | 80   |
| Flixx 300/400 Square                          | 108  | Scout Next                             | 50   |
| Flixx 320 Round Wallwasher                    | 110  | StraitLine 60                          | 120  |
| FLC   | 192  | StraitLine 60 Spot                     | 122  |
| Fyrra   | 186  | <b>T</b>                               |      |
| <b>J</b>                                      |      | Torpedo 200                            | 52   |
| Jamie 200                                     | 44   | Torpedo 250                            | 112  |
| Jamie 300                                     | 46   | Torpedo 300                            | 54   |
| Jett 100                                      | 48   | Torpedo 350                            | 114  |
| <b>L</b>                                      |      | Trentino II Ceiling                    | 166  |
| Lunata Direct-Indirect with Light Effect Ring | 126  | Trentino II Pendant                    | 168  |
| Lunata Direct without Light Effect Ring       | 128  | Trentino II Stand                      | 176  |
| LUZ Surface-Mounted                           | 130  | <b>V</b>                               |      |
| LUZ Recessed Standard                         | 132  | Vario Classic                          | 90   |
| LUZ Pendant                                   | 134  | Vale-Tu Flat                           | 116  |
| LUZ Track-Mounted                             | 136  | Vale-Tu Round Small/Medium             | 82   |
| LUZ Track-Mounted Pendant                     | 138  | Vale-Tu Round XSmall                   | 84   |
| LUZ Wall                                      | 180  | Vale-Tu Square Small/Medium            | 86   |
|   |      | Vale-Tu Square XSmall                  | 88   |

# Index

## Variety by Product Category

| Article name                      | Page | Article name                                  | Page |
|-----------------------------------|------|---|------|
| <b>Track-Mounted Spotlights</b>   |      | <b>Ceiling &amp; Pendant Luminaires</b>       |      |
| Bixx 100                          | 38   | Lunata Direct-Indirect with Light Effect Ring | 126  |
| BixxL 200                         | 40   | Lunata Direct without Light Effect Ring       | 128  |
| EuroLED                           | 42   | LUZ Surface-Mounted                           | 130  |
| Jamie 200                         | 44   | LUZ Recessed Standard                         | 132  |
| Jamie 300                         | 46   | LUZ Pendant                                   | 134  |
| Jett 100                          | 48   | LUZ Track-Mounted                             | 136  |
| Scout Next                        | 50   | LUZ Track-Mounted Pendant                     | 138  |
| Torpedo 200                       | 52   | Monoline 070 Surface-Mounted & Pendant        | 140  |
| Torpedo 300                       | 54   | Piano Pendant                                 | 144  |
|                                   |      | PL 20 Surface-Mounted & Pendant               | 146  |
|                                   |      | PL 22 Surface-Mounted & Pendant               | 148  |
|                                   |      | PL 25 Recessed Trimless                       | 150  |
|                                   |      | PL 26 Direct-Indirect Surface-Mounted         | 152  |
|                                   |      | PL 27 Recessed                                | 154  |
|                                   |      | PL 28 Direct-Indirect Pendant                 | 156  |
|                                   |      | PL 50 Surface-Mounted & Pendant               | 158  |
|                                   |      | PL 52 Surface-Mounted & Pendant               | 160  |
|                                   |      | PL 55 Recessed Trimless                       | 162  |
|                                   |      | PL 57 Recessed                                | 164  |
|                                   |      | Trentino II Ceiling                           | 166  |
|                                   |      | Trentino II Pendant                           | 168  |
| <b>Recessed Spotlights</b>        |      | <b>Free-Standing Luminaires</b>               |      |
| CSA 40                            | 58   | Ascona  | 172  |
| CSA 50                            | 60   | Piano Stand                                   | 174  |
| CSA 60                            | 62   | Trentino II Stand                             | 176  |
| CSA 72 Round                      | 64   |   |      |
| Dallton XSmall                    | 66   |   |      |
| Dallton Small                     | 68   |   |      |
| Dallton Medium                    | 70   |   |      |
| Dallton Large                     | 72   |   |      |
| Scene 1 System                    | 76   |   |      |
| Scene 33 System                   | 78   |   |      |
| Scene 4 System                    | 80   |   |      |
| Vale-Tu Round Small/Medium        | 82   |   |      |
| Vale-Tu Round XSmall              | 84   |   |      |
| Vale-Tu Square Small/Medium       | 86   |   |      |
| Vale-Tu Square XSmall             | 88   |   |      |
| Vario Classic                     | 90   |   |      |
| <b>Surface-Mounted Downlights</b> |      | <b>Wall Luminaires</b>                        |      |
| Button 300                        | 94   | LUZ Wall                                      | 180  |
| Button Mini 100/200               | 96   | PL 23 Wall                                    | 182  |
| <b>Recessed Downlights</b>        |      | <b>Insert Luminaires</b>                      |      |
| Flixx 100/200 Round               | 100  | Fyrra   | 186  |
| Flixx 100/200 Square              | 102  | Optico  | 188  |
| Flixx 300 Flat Round              | 104  |   |      |
| Flixx 300/400 Round               | 106  |   |      |
| Flixx 300/400 Square              | 108  |   |      |
| Flixx 320 Round Wallwasher        | 110  |   |      |
| Torpedo 250                       | 112  |   |      |
| Torpedo 350                       | 114  |   |      |
| Vale-Tu Flat                      | 116  |   |      |
| <b>Lighting Systems</b>           |      | <b>High-Bay Luminaires</b>                    |      |
| StraitLine 60                     | 120  | FLC   | 192  |
| StraitLine 60 Spot                | 122  |   |      |
|                                   |      | <b>Contact Tracks &amp; Accessories</b>       |      |
|                                   |      | ONETrack Surface-Mounted                      | 198  |
|                                   |      | ONETrack Recessed                             | 200  |

# General Terms and Conditions

## I Scope of Application

- 1) The present General Terms and Conditions (GTC) shall apply to all business relations between LTS Licht & Leuchten GmbH (referred to as "Supplier" below) and the customer (referred to as "Purchaser" below). The GTC shall only apply if the Purchaser is an entrepreneur (§ 14 BGB, German Civil Code), a legal entity under public law or a special fund under public law.
- 2) These General Terms and Conditions shall also be deemed included and applicable in any future business relationships also if they are not expressly referred to again.
- 3) Any individual covenants agreed on a case-to-case basis with the Purchaser (including any side agreements or amendments) shall in all cases have precedence over these GTC. The content of such covenants shall be evidenced by a written contract or a written confirmation of the Supplier unless proof of the contrary is provided.
- 4) Our General Terms and Conditions shall be valid exclusively. Any differing, conflicting or supplementary General Terms and Conditions of the Purchaser shall only become part of the contract if and to the extent the Supplier expressly confirms their validity. This confirmation requirement shall apply in any case, including but not limited to the case where the Supplier is aware of the Purchaser's GTC and executes delivery to the Purchaser without making a reservation to this effect.
- 5) All legally relevant statements and notifications of the Purchaser regarding the contract (e.g. setting of time-limits, notification of defects, cancellation or reduction in price) shall be made in writing, i.e. in written/text form (e.g. letter, e-mail, telefax). The formal legal requirements and other evidence – particularly in case of doubt about the legitimation of the person making the statement – shall remain unaffected.

## II Conclusion of Contract/Content of Contract/Prices

- 1) The Supplier's offer is subject to confirmation. This shall also apply if the Supplier submitted catalogues, product descriptions or technical documentation (e.g. drawings, plans, calculations) to the Purchaser in the run-up to the contract, unless otherwise expressly agreed.
- 2) The purchase order submitted by the Purchaser for the goods shall be considered as a binding offer to enter into a contract. The Supplier shall be entitled to accept this offer of contract within 1 week after receipt unless otherwise evident from the purchase order.
- 3) Acceptance of the offer is declared by the Supplier either in writing (e.g. by an order confirmation) or by delivery to the Purchaser. The content and scope of supplies and services shall be governed by the Supplier's written order confirmation. The decisive nature of the written order confirmation shall also apply to any purchase orders placed with the Supplier's sales agents and/or field representatives.
- 4) The Supplier's information about the subject of the supply or service (e.g. weights, dimensions, serviceability, capacity, tolerances and technical data) and any representation thereof (e.g. drawings and figures) is only approximative information unless its usability for the contractual purpose requires precisely matching data. Such information does not constitute warranted properties but merely describes or identifies the supply or service. Deviations usual in the trade and deviations occurring due to legal requirements or constituting technical improvements as well as any substitution of components by other equivalent parts shall be acceptable as long as this does not affect the usability for the contractual purpose.
- 5) The basis for price calculations shall be the price lists valid at the time of signing a contract or the object-specific prices specified in an offer, as applicable.
- 6) Prices are understood plus value added tax at the applicable statutory rate unless already included. For a net value of the goods of less than 250.00 €, an extra charge for small quantities in the amount of 50.00 € plus value added tax at the applicable statutory rate will be charged in addition. All prices indicated shall apply within the Federal Republic of Germany (except German islands) including costs of freight and transport unless otherwise agreed. Deliveries to German islands and outside of the Federal Republic of Germany are subject to an individual agreement. If the Purchaser should want to have the shipment sent by express, this must be expressly agreed along with the express charges incurred.
- 7) The Supplier reserves the property and copyright regarding the use of quotations, drawings and other documents (referred to as "documents" below) without any restriction. Documents shall not be disclosed to any third party without the prior consent of the Supplier and must be returned immediately on request if the order is not placed with the Supplier. Phrases 1 and 2 shall apply accordingly for Purchaser's documents, however, these may be disclosed to those third parties which have been appropriately commissioned with deliveries by the Supplier.

## III Delivery Periods/Delay in Delivery

- 1) The delivery period shall be agreed individually or specified by the Supplier when accepting the purchase order. Otherwise the delivery period shall be about 4 weeks from conclusion of contract.
- 2) Compliance with delivery periods is contingent upon timely receipt of any and all specifications, documents, necessary licenses and approvals to be provided by the Purchaser, particularly any drawings, and adherence to the agreed terms of payment and other obligations on the part of the Purchaser. If these prerequisites are not fulfilled in due time, the delivery periods shall be extended reasonably and proportionately unless the delay should be attributable to the Supplier.
- 3) Any fixed-date contracts (§ 376 HGB – German Commercial Code) are subject to express agreement.
- 4) If the Supplier should be unable to keep a binding delivery period for reasons beyond its control (unavailability of service), it will inform the Purchaser about

this without delay and communicate the anticipated new delivery period at the same time. If the service should still be unavailable within the new delivery period, the Supplier shall be entitled to cancel the contract in full or in part; any consideration already effected by the Purchaser will be reimbursed without delay. This concept of unavailability of service shall include, without limitation, failure of timely delivery by the Supplier's sub-supplier if the latter had concluded a congruent covering contract, neither the Supplier nor the sub-supplier is at fault or the Supplier should not be obliged to make the procurement in an individual case.

5) The existence of a delay in delivery of the Supplier shall be governed by the statutory provisions. However, a reminder by the Purchaser shall be required in any case. If the Supplier should get into delay in delivery, the Purchaser shall be entitled to claim liquidated damages due to delay. The flat charge for damages shall be 0.5% of the net price (delivery value) for each full calendar week of delay, however, not exceeding a total value of 5% of the delivery value of the goods delivered with a delay. The Supplier shall be at liberty to prove that the Purchaser has not suffered any loss or only a substantially lower loss than the flat charge specified above.

6) The Purchaser is obliged to state on Supplier's request and within reasonable time whether it will cancel the contract for delay in delivery and/or demand damages in lieu of performance and/or insist on delivery.

7) The Purchaser's rights according to clause IX of these GTC and the Supplier's statutory rights – particularly in case of inapplicability of the obligation to perform (e.g. impossibility or unreasonableness of rendering the service and/or remedial performance) shall remain unaffected.

## IV Delivery/Passage of Risk/Acceptance/Delay in Acceptance

- 1) Shipment will be made within the Federal Republic of Germany (except German islands), unless otherwise agreed, by order of the Supplier and by a carrier of its choice. The Supplier shall make the goods available at the place of destination ready for unloading but not yet unloaded. The Supplier shall bear all costs and risks as far as to the agreed destination and not yet unloaded (DAP Incoterms 2010). Deliveries to German islands and outside of the Federal Republic of Germany and express deliveries are subject to an individual agreement.
- 2) The Purchaser shall designate in reasonable time before shipment of the goods one or more persons by name who are definitely authorized to receive the shipment and sign the delivery note. This shall apply particularly if the goods are to be shipped to a destination other than the Purchaser's domicile.
- 3) If the Purchaser should refuse acceptance without justification, fail to cooperate as required or if delivery by the Supplier is delayed for other reasons for which the Purchaser is responsible, the Purchaser shall be deemed in default of acceptance and the risk passes to the Purchaser. In this case the Supplier shall be entitled to demand compensation for the loss thereby incurred, including any additional expenses (e.g. storage costs). If the Supplier should incur storage expenses, these shall be subject to a flat charge of 0.25% of the invoice amount for the delivery goods to be stored per month or part thereof. The Supplier reserves the right to claim higher or lower costs of storage.
- 4) The Supplier shall only be entitled to make partial deliveries if
  - the partial shipment can be used by the Purchaser within the scope of the contractual intended use,
  - delivery of the remaining goods ordered is ensured and
  - the Purchaser does not incur any substantial additional efforts or costs (unless the Supplier is prepared to bear these costs).

## V Terms of Payment

- 1) The purchase price shall be due and payable within 14 days from receipt of invoice and delivery of the goods.
- 2) After expiry of the above period allowed for payment, the Purchaser shall be in default. The purchase price is subject to interest for delay at the current statutory rate during the period of delay. The Supplier reserves the right to claim additional damages for delay. In relation to merchants/entrepreneurs, the claim to the commercial interest rate for delay (§ 353 HGB - German Commercial Code) shall remain unaffected.
- 3) The Supplier is not obliged to accept any bills of exchange. These will only be accepted on a case-to-case basis in lieu of performance and subject to specific agreements. Payment shall not be deemed effected until the cheque or bill of exchange has been honoured. Any discount and acceptance charges for a bill of exchange shall be at the expense of the drawer of the bill on the due date of the claim and are payable in cash immediately.
- 4) Notwithstanding any payment conditions agreed separately on a case-to-case basis, any claims to which the Supplier may be entitled shall become due and payable immediately if any circumstances should occur about the person of the Purchaser which make it unacceptable to continue with the payment terms agreed. This applies in particular if there are reasonable indications of a substantial deterioration of the financial standing of the Purchaser, including but not limited to stoppage of payments, cheque or bill protest or delay in payment, if it becomes evident that the Supplier's claim to payment of the consideration is jeopardized by a lack of capacity of the Purchaser. In these cases, the Supplier shall additionally be entitled to demand matching of payments with deliveries or demand further securities. The Supplier shall furthermore be entitled to set a reasonable time-limit within which the Purchaser has to match payment with delivery, providing either consideration or security at the Supplier's discretion. If this time-limit should elapse without success, the Supplier shall be entitled to cancel the contract.
- 5) The Purchaser shall only be entitled to assert a right to set-off or retention to the extent its claim is established as final and absolute uncontested. In case of defects of the delivery, any counter-claims of the Purchaser shall remain unaffected, including but not limited to those pursuant to clause VII 4) of these GTC.



## VI Retention of Title

- 1) The goods delivered (goods subject to retention of title) shall remain the Supplier's property until any and all claims to which the Supplier may be entitled versus the Purchaser from the business relationship are settled.
- 2) The Purchaser must neither pledge nor transfer by way of security any goods as long as they are subject to retention of title. In case of an order of attachment, seizure or other dispositions or interventions of any third party, the Purchaser shall notify the Supplier without delay.
- 3) The Purchaser shall be entitled to resell the goods subject to retention of title in the course of ordinary business if the Purchaser receives the compensation agreed or if prohibition of assignment is not agreed. The Purchaser hereby and now assigns to the Supplier by way of security any claim to the purchase price to which Purchaser may be entitled from resale. However, the Purchaser shall continue to be entitled to collect the claims assigned by way of security unless and until this authorization should be revoked. The authorization may be revoked if the Purchaser culpably fails or ceases to meet its contractual obligations. If the collection authorization should be revoked, the Supplier shall be entitled to notify the assignment effected. The Purchaser shall be obliged to make the documents required for notification of the assignment and for collection available without delay.
- 4) If the Purchaser should pledge the goods subject to retention of title to a third party or transfer them by way of security contrary to paragraph 2 and/or make them subject of a factoring and/or sale-lease-back scheme, this shall not be considered as a resale in the ordinary course of business.
- 5) In case of conversion and/or further processing of goods subject to retention of title, this shall be by order and on behalf of the Supplier as the manufacturer pursuant to §§ 950 ff. BGB. In this case, the Supplier shall have (joint) ownership in the goods produced by conversion and/or further processing of the goods subject to retention of title in proportion with the value of the goods subject to retention of title and the value of the new goods at the time of conversion and/or further processing. Moreover, the Supplier shall be entitled to proportional joint ownership of the new goods if goods of third parties are included in the processing of the goods subject to retention of title. If the Purchaser should resell the new goods produced, the Purchaser hereby and now assigns to the Supplier by way of security any claim to which Purchaser may be entitled from resale in the amount of the value of the goods subject to retention of title.
- 6) In case of any damage or other deterioration of the goods subject to retention of title, the Purchaser shall notify the Supplier without delay. The Purchaser hereby and now assigns to the Supplier by way of security any claim against any third party to which Purchaser may be entitled from the damage or deterioration.
- 7) Insofar as the value of all liens to which the Supplier may be entitled should exceed the amount of all claims secured by more than 20 %, the Supplier will release a proportionate part of the liens on Purchaser's request.
- 8) In case of a breach of duties on the part of the Purchaser, including but not limited to default of payment, the Supplier shall be entitled to cancel the contract and take back the goods subject to retention of title. The Purchaser is obliged to surrender them. The Supplier's taking back the goods subject to retention of title and/or assertion of the retention of title alone does not require Supplier's cancellation of contract and shall not be deemed as an implied notice of cancellation of contract unless the Supplier states expressly that these actions be considered as cancellation.

## VII Warranty

- 1) With regard to the Purchaser's rights in the case of defects as to quality or title, the statutory regulations shall apply unless otherwise stipulated below. In all cases, the special statutory provisions relating to final delivery of goods to consumers shall remain unaffected (supplier regress pursuant to §§ 478, 445a, 445b BGB).
- 2) The Purchaser shall inspect the goods delivered for proper condition without delay and notify any obvious defects to the Supplier within a period of 10 days from receipt of goods in written or text form (e.g. letter, e-mail, telefax). For hidden defects, this time-limit shall apply accordingly as soon as they are discovered. If the Purchaser should fail to make this inspection and/or notification of defect, the Supplier's liability shall be excluded for the defect not notified in time or properly or not at all in accordance with the statutory regulations.
- 3) In case of a justified complaint, i.e. if there are defects in quality, the cause of which had already existed at the point of time of passage of risk, the Supplier shall have the option of repair (rectification of defect) or replacement (subsequent delivery) at its discretion. The Supplier's right to refuse supplementary performance under the statutory provisions shall remain unaffected.
- 4) The Supplier is entitled to make any supplementary performance owed contingent upon Purchaser's payment of the purchase price due. However, the Purchaser is entitled to retain a part of the purchase price in reasonable and acceptable proportion with the defect.
- 5) If the Supplier should choose to deliver an item free of defects by way of supplementary performance, the Purchaser shall be obliged to surrender the defective item. The same shall apply accordingly for defective components if these are replaced by components free of defects by way of repair. The provisions of § 439 para. 2, 3 and 4 BGB and § 445a BGB shall remain unaffected.
- 6) If supplementary performance failed or a reasonable time-limit to be set by the Purchaser for supplementary performance should have elapsed unsuccessfully, the Purchaser shall be entitled to cancel the contract or reduce the purchase price. However, there is no right to cancel the contract for minor defects.
- 7) Purchaser's claims for defects shall not be justified for ordinary wear and tear or any damage caused after passage of risk as a result of improper or negligent treatment, excessive strain, use of inappropriate materials, poor construction work, inadequate foundations or due to extraordinary outside

effects which were not anticipated when concluding the contract. If the Purchaser or any third party should make any inappropriate modifications or repairs, these and any resulting consequences shall not justify any claims for defects.

8) In all other respects, section IX shall govern any claims for damages. Any claims of the Purchaser against the Supplier and the latter's vicarious agents for material defects beyond or other than those addressed in this clause and clause IX shall be excluded.

9) The Supplier offers a warranty of 5 years for the LED standard products. For the LED standard luminaires, the Supplier warrants 50,000 hours within 5 years for the rating L80 B20.

## VIII Return of Goods

1) Returning of goods free of defects is subject to the Supplier's prior consent. For this purpose, the Supplier will send a goods return voucher form to the Purchaser. Goods returned shall exclusively be accepted subject to the conditions specified in the goods return voucher; these conditions are deemed to be accepted by the Purchaser by returning the goods. LED products are only taken back by the Supplier within 90 days and in original sealed packaging. If goods are returned without a goods return voucher, the Supplier shall be entitled to refuse acceptance of the goods.

2) The Supplier charges a flat rate of 20% of the value of the goods for handling and processing expenses for goods returned. The Purchaser shall be at liberty to prove that the Supplier's loss is actually lower. The Purchaser shall bear any and all costs of transport, packaging, outer packaging and any repair, if applicable.

## IX Damages/Liability

1) In case of any violation of contractual and non-contractual duties, the Supplier shall be liable according to the statutory regulations insofar as there are no other stipulations in these General Terms and Conditions including the subsequent provisions.

2) The Supplier shall be liable for damages – regardless of the legal basis – under the concept of tortious liability in case of intent or gross negligence. In cases of ordinary negligence, the Supplier shall be liable – with the reservation of a lower level of liability according to statutory provisions (e.g. due care as in its own affairs) – only

- a) for injuries of life, limb or health,
- b) for damage resulting from a significant violation of an essential contractual obligation (an obligation which is a prerequisite for proper execution of the contract and the fulfilment of which the contractual partner does and may regularly rely on); however, in this case the Supplier's liability shall be limited to compensating for the foreseeable typical damage.

3) The limitation of liability pursuant to para. 2 shall also apply to any breach of duty by or to the benefit of persons for faults of whom the Supplier is responsible under statutory provisions. They shall not apply insofar as the Supplier has fraudulently concealed a defect or offered a warranty for the condition of the goods and for any claims of the Purchaser under the product liability legislation.

## X Statutory Limitation

1) Notwithstanding § 438 para. 1 no. 3 BGB, the general statutory period of limitation for claims for defects in quality and title shall be one year from the date of delivery. If an acceptance procedure has been agreed, statutory limitation shall begin on acceptance.

2) However, if the subject-matter is a building or an item used for a building according to its typical use and caused its deficiency (construction material), the statutory period of limitation pursuant to the statutory regulations is 5 years from delivery (§ 438 para. 1 no. 2 BGB). Any other special regulations on statutory limitation shall also remain unaffected (including but not limited to § 438 para. 1 no. 1, para. 3, §§ 444, 445b BGB).

3) The above specified statutory periods of limitation of commercial law shall also apply to any contractual or non-contractual claims for damages of the Purchaser based on a defect of the goods, unless application of standard statutory limitation (§§ 195, 199 BGB) would result in a shorter period of limitation in an individual case. However, any claims for damages of the Purchaser pursuant to clause IX para. 2 phrase 1 and phrase 2(a) as well as under product liability legislation shall exclusively be governed by the statutory periods of limitation.

## XI Final Provisions

1) The legal relationship under this contract shall be governed by material German law, excluding the application of the United Nations Convention on International Sale of Goods.

2) If the customer is a merchant/entrepreneur or a legal entity under public law or a special fund under public law, the legal venue for all disputes arising out of the contractual relationship shall be the domicile of the Supplier as far as legally admissible. The supplier shall also be entitled to take action before the court having jurisdiction for the Purchaser's domicile. Any imperative regulations on exclusive venues shall remain unaffected by this provision.

3) If any provision of these General Terms and Conditions or any clause contained in other agreements should be or become void, this shall not affect the validity of all other provisions or agreements.

# Imprint

## Issued by

LTS Licht & Leuchten GmbH  
Waldesch 24  
88069 Tettnang  
Germany

T +49 7542 9307-0  
info@lts-light.com  
lts-light.com

A MEMBER OF THE FAGERHULT GROUP



## Concept + Design

BECKDESIGN GmbH  
Auf der Heide 3  
44803 Bochum  
Germany

beckdesign.de

## Production

Kollin Medien GmbH  
Gutenbergstraße 1-3  
95512 Neudrossenfeld  
Germany

kollin.de



### PEFC zertifiziert

Gedruckt auf  
PEFC-zertifiziertem Papier  
stammt aus nachhaltig  
bewirtschafteten Wäldern und  
kontrollierten Quellen.

[www.pefc.de](http://www.pefc.de)

# Legend

|  |  |   |  |
|--|--|---|--|
| Energy efficiency rating                                     | Average service life   | IEC protection: Class III   | Special light colour for lighting fruit and vegetables       |
| CE conformity  | LED colour rendering index                                   | EU directive 2001/65/EU Restriction of the use of certain hazardous substances in electrical and electronic equipment | Special light colour for lighting fashion products           |
| Beam angle   | IP rated   | Tunable White Light LED white spectrum for spots (2700–6500 K) and for linear and surface modules (3000–6000 K)       | Suitable for concrete installation                           |
| Batwing reflector, e.g., for lighting aisles between shelves | IK code  | Tunable White PiLED LED white spectrum: 2500–7000 K + colour, suitable for Human Centric Lighting applications        | Installation with leaf spring                                |
| Wallwasher for uniform illumination of vertical surfaces     | Product colour   | Trooping function Luminaire communication system for light and motion   | Emergency lighting function                                  |
| HBT version for accentuated lighting                         | Colour temperature in K                                      | Automatic daylight and presence sensors   | Weight in kg   |
| Dimmable   | MinusBlue High-performance LEDs for a natural light spectrum | Special light colour for lighting bakery products   | This luminaire is also available in a more powerful version. |
| Dimmable via DALI bus  | IEC protection: Class I                                      | Special light colour for lighting meat and sausage products   |  |

In the catalogue, all items are listed in the most popular colour temperature and with standard beam angles. Of course, our products are also available with other features which can be viewed via icons.



While standard options are available as part of our portfolio, we explicitly manufacture products with special options.

You can find our entire product range online. Please use the weblink provided on the right-hand product page of the catalogue, where you can also easily inquire about prices.



